



tnc



www.dynawave.com

dynawave
INCORPORATED

TNC • interface dimensions

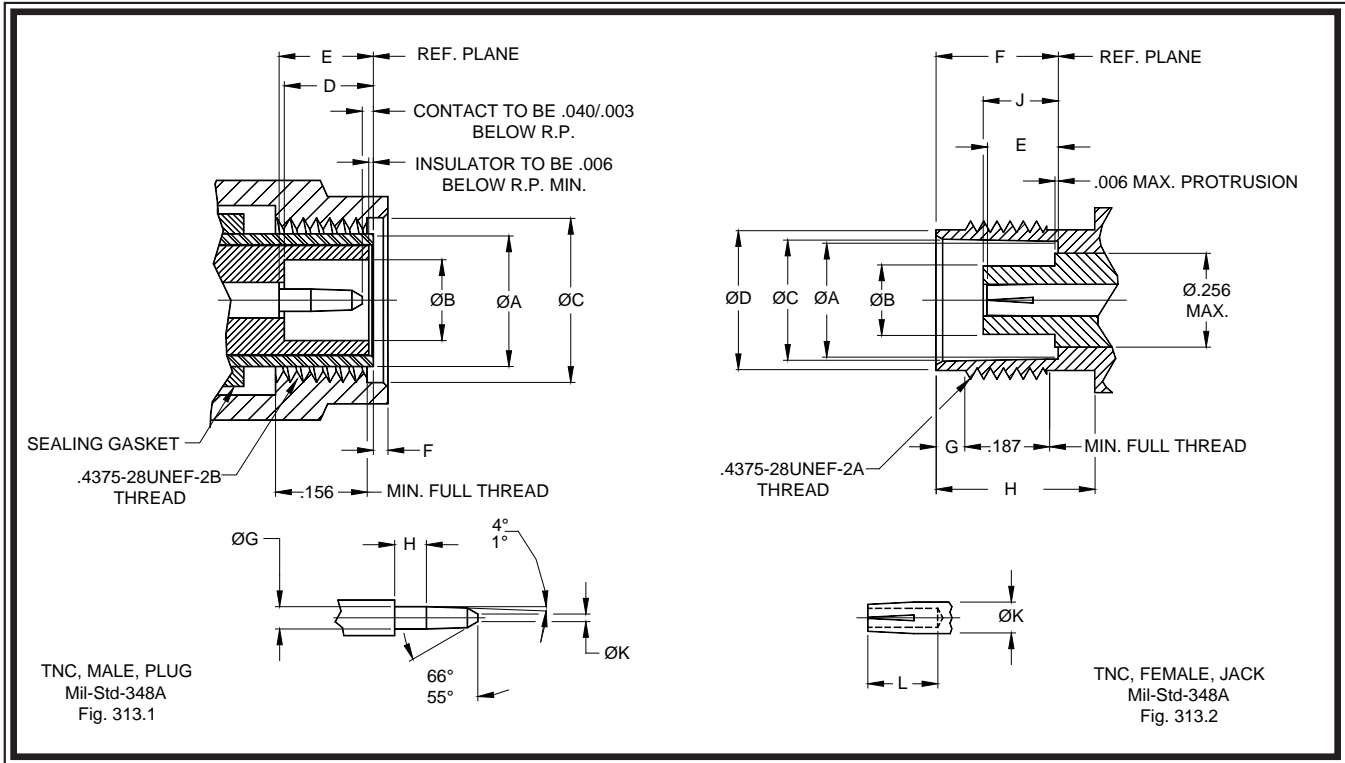

male, plug

female, jack

LTR.	INCHES / MILLIMETERS ³			
	MINIMUM		MAXIMUM	
	IN.	MM.	IN.	MM.
A	.314	7.98	.318	8.08
B	.190	4.83	-----	-----
C	.440	11.18	-----	-----
D	.208	5.28	.228	5.79
E	.210	5.33	.230	5.84
F	-----	-----	.078	1.98
G	.052	1.32	.054	1.37
H	.078	1.98	-----	-----
J	-----	-----	-----	-----
K	-----	-----	-----	-----
L	-----	-----	-----	-----

LTR.	INCHES / MILLIMETERS ³			
	MINIMUM		MAXIMUM	
	IN.	MM.	IN.	MM.
A	.319	8.10	.321	8.15
B	.182	4.62	.186	4.72
C	.319	8.10	.321	8.15
D	.378	9.60	.381	9.68
E	.186	4.72	.206	5.23
F	.327	8.31	.335	8.51
G	.068	1.73	.088	2.24
H	.414	10.52	-----	-----
J	.188	4.78	.208	5.28
K	.084	2.13	.087	2.21
L	.195	4.95	-----	-----

Notes:

1. I.D. to meet VSWR and contact resistance when mated with .054 / .052 Dia. inches (1.37 / 1.32) Dia. millimeter pin.
2. When fully engaged, the two reference planes must coincide with metal-to-metal contact.
3. Metric equivalents (to the nearest 0.01mm) are given to general information only and are based on 1.0 millimeter=.03937 inches.
4. These dimensions are subject to change according to the latest revisions of MIL-C-39012 and MIL-STD-348A.

Specifications are subject to change without notice

TNC specifications

The specifications below are general specifications for all TNC connectors. Specific specifications for VSWR, insertion loss and R.F. leakage for each connector is available from Dynawave upon request. Specifications in the following table are recommended for any procurement documents or drawings

In the event of any conflict between these specifications and General Specification MIL-C-39012 these specifications shall govern. These specifications are subject to change according to the latest revision of MIL-C-39012.

REQUIREMENT	MIL-C-39012 PARAGRAPH	SPECIFICATIONS
GENERAL		
Material	3.3	Steel corrosion resistant per ASTM- A- 581, Type 303, Cond. A Beryllium copper per ASTM-B196/B, 196M, Copper Alloy TFE Fluorocarbon per ASTM-D-1710, Type 1, Grade 1, Class B. Silicone Rubber per ZZ-R-765, CLASS IIB. 50-60 Shore.
Finish	3.3.1	Center contacts shall be gold plated to a minimum thickness of .00005-inch in accordance with ATSM-B-488, Type I, Code C. All other metal parts shall be finished so as to provide a connector which meets the corrosion requirements of this table.
Design	3.4	The design shall be such that the outline dimensions in this catalog are met. In addition the assembled connector shall meet the interface dimensions.
ELECTRICAL		
Insulation Resistance	3.11	The insulation resistance shall not be less than 5,000 megohms
Dielectric Withstanding Voltage	3.17	The magnitude of the test voltage shall be 1,500 volts rms at sea level
RF High Potential Withstanding Voltage	3.23	The RF high potential withstanding voltage is 1,000 volts rms at 5 MHz. Leakage is not applicable.
Contact Resistance	3.18	The center contact resistance drop shall not exceed 1.5 milliohms and the outer contact resistance drop shall not exceed 2.0 milliohms.
Voltage Standing Wave Ratio (VSWR)	3.14	See applicable connector specifications.
RF Leakage	3.26	See applicable connector specifications.
Insertion Loss	3.27	See applicable connector specification.
MECHANICAL		
Force to Engage and Disengage	3.5.1	The torque required to engage and disengage shall not exceed 2 inch-pounds. The longitudinal force is not applicable
Coupling Nut Retention Force and Proof Torque.	3.25	Not applicable for Female connectors. For Male connectors, the retension force is 100 pounds minimum. The Proof torque is 30 inch-pounds minimum.
Cable Retention force	3.24	The force applied shall be 60 pounds minimum. The cable twisting and bending requirements shall not apply.
Mating Characteristics	3.7	See interface dimensions shown on Page 194. Applicable to Females only: oversize pin .055 minimum diameter .150 deep; Insertion force 2 pounds maximum with .054 minimum diameter pin; withdrawal force 2 ounce minimum with .052 maximum diameter pin.
Connector Durability	3.15	The connector to be tested and its mating connector shall be subjected to 500 insertions and withdrawal cycles at 12 cycles per minute maximum. The connector shall show no evidence of mechanical failure and connector shall meet the mating characteristic requirements.
ENVIRONMENTAL		
Vibration	3.18	Specification MIL-STD-202, Method 204, Test Condition D.
Shock	3.19	Specification MIL-STD-202, Method 213, Test Condition I.
Thermal Shock	3.20	Specification MIL-STD-202, Method 107, Test Condition B except high temperature shall be $\pm 200^{\circ}\text{C}$.
Recommended Mating Torque		12-15 inch-pounds
Corrosion (Salt Spray)	3.13	Specification MIL-STD-202, Method 101, Test Condition B. The salt solution shall be five per cent.
Moisture Resistance	3.21	Specification MIL-STD-202, Method 106. Step 7b (vibration) shall be omitted. Insulation resistance shall be 200 megohms minimum within 5 minutes of removal from humidity.
Corona Level	3.22	The connector shall not exhibit breakdown (corona) when the applied voltage is 375 volts rms and the altitude is 70,000 feet.
Complete specifications on every connector in this catalog are available from Dynawave		

Specifications are subject to change without notice

TNC • semi rigid cable connectors

male, plug, straight, with center contact

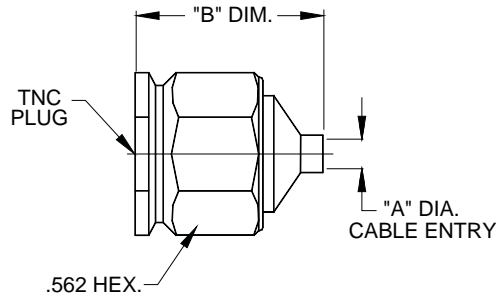

PART NUMBER	"A" DIA.	"B" DIM.	CABLE TYPE	MATERIAL TYPE	FREQUENCY RANGE
8400-8521-2700	.089 MIN.	.77	RG 405/U (.085)	BRASS	DC - 18.0 GHz.
8400-4121-2700	.144 MIN.	.76	RG 402/U (.141)	BRASS	DC - 18.0 GHz.
8400-8521-6200	.089 MIN.	.77	RG 405/U (.085)	STAINLESS STEEL	DC - 18.0 GHz.
8400-4121-6200	.144 MIN.	.76	RG 402/U (.141)	STAINLESS STEEL	DC - 18.0 GHz.
8400-2525-2700	.255 MIN.	.97	RG 401/U (.250)	BRASS	DC - 18.0 GHz.
8400-2525-6201	.255 MIN.	1.02	RG 401/U (.250)	STAINLESS STEEL	DC - 18.0 GHz.

male, plug, straight, with center contact

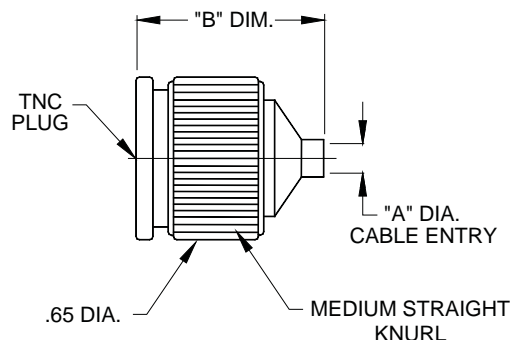

PART NUMBER	"A" DIA.	"B" DIM.	CABLE TYPE	MATERIAL TYPE	FREQUENCY RANGE
8400-8521-2701	.089 MIN.	.77	RG 405/U (.085)	BRASS	DC - 18.0 GHz.
8400-4121-2701	.144 MIN.	.77	RG 402/U (.141)	BRASS	DC - 18.0 GHz.
8400-8521-6201	.089 MIN.	.77	RG 405/U (.085)	STAINLESS STEEL	DC - 18.0 GHz.
8400-4121-6201	.144 MIN.	.77	RG 402/U (.141)	STAINLESS STEEL	DC - 18.0 GHz.
8400-2525-2702	.255 MIN.	.97	RG 401/U (.250)	BRASS	DC - 18.0 GHz.
8400-2525-6202	.255 MIN.	.97	RG 401/U (.250)	STAINLESS STEEL	DC - 18.0 GHz.

Specifications are subject to change without notice

TNC • semi rigid cable connectors

female, jack, straight

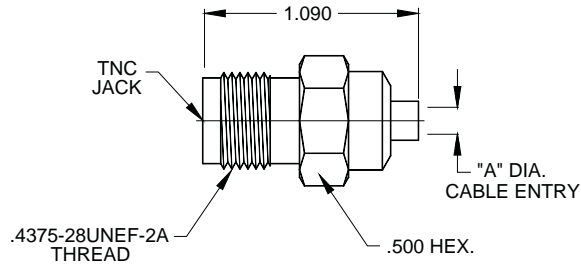

PART NUMBER	"A" DIA.	CABLE TYPE	MATERIAL TYPE	FREQUENCY RANGE
8500-8521-2700	.089 MIN.	RG 405/U (.085)	BRASS	DC - 18.0 GHz.
8500-4121-2700	.144 MIN.	RG 402/U (.141)	BRASS	DC - 18.0 GHz.
8500-8521-6400	.089 MIN.	RG 405/U (.085)	STAINLESS STEEL	DC - 18.0 GHz.
8500-4121-6400	.144 MIN.	RG 402/U (.141)	STAINLESS STEEL	DC - 18.0 GHz.
8500-2525-2700	.255 MIN.	RG 401/U (.250)	BRASS	DC - 18.0 GHz.
8500-2525-6400	.255 MIN.	RG 401/U (.250)	STAINLESS STEEL	DC - 18.0 GHz.

female, jack, bulkhead mount, solder clamp

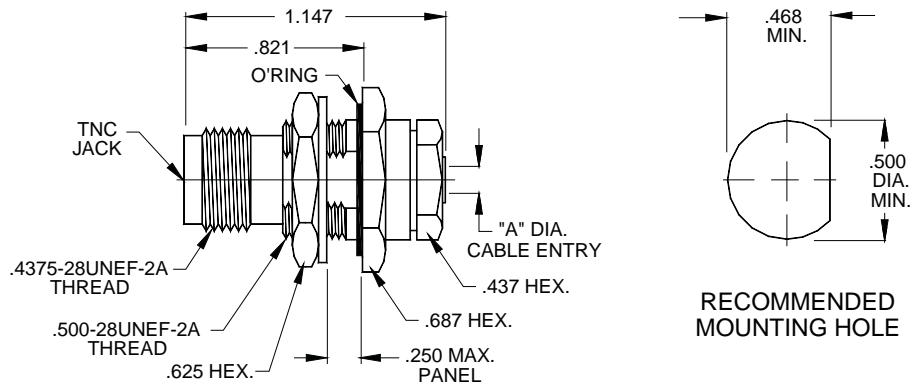

PART NUMBER	"A" DIA.	CABLE TYPE	MATERIAL TYPE	FREQUENCY RANGE
8510-8521-2700	.089 MIN.	RG 405/U (.085)	BRASS	DC - 18.0 GHz.
8510-4121-2700	.144 MIN.	RG 402/U (.141)	BRASS	DC - 18.0 GHz.
8510-8521-6200	.089 MIN.	RG 405/U (.085)	STAINLESS STEEL	DC - 18.0 GHz.
8510-4121-6200	.144 MIN.	RG 402/U (.141)	STAINLESS STEEL	DC - 18.0 GHz.
8510-2521-2700	.255 MIN.	RG 401/U (.250)	BRASS	DC - 18.0 GHz.
8510-2521-6200	.255 MIN.	RG 401/U (.250)	STAINLESS STEEL	DC - 18.0 GHz.

Specifications are subject to change without notice

TNC • semi rigid cable connectors

female, jack, 4 hole flange mount

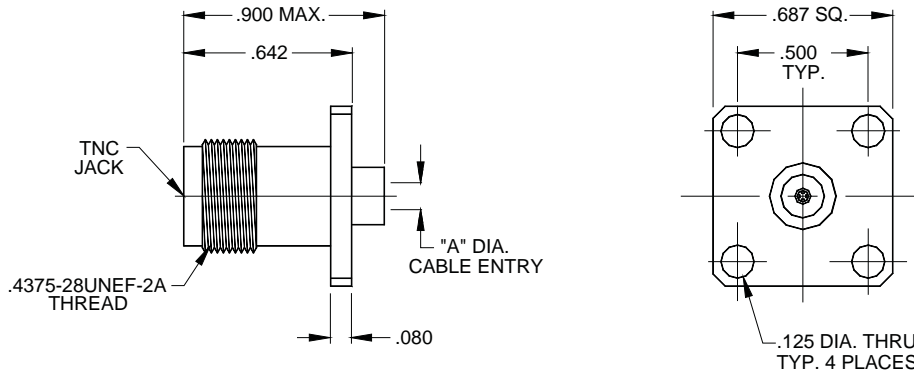

PART NUMBER	"A" DIA.	CABLE TYPE	MATERIAL TYPE	FREQUENCY RANGE
8554-8521-2700	.089 MIN.	RG 405/U (.085)	BRASS	DC - 18.0 GHz.
8554-4121-2700	.144 MIN.	RG 402/U (.141)	BRASS	DC - 18.0 GHz.
8554-8521-6400	.089 MIN.	RG 405/U (.085)	STAINLESS STEEL	DC - 18.0 GHz.
8554-4121-6400	.144 MIN.	RG 402/U (.141)	STAINLESS STEEL	DC - 18.0 GHz.
8554-2521-2700	.255 MIN.	RG 401/U (.250)	BRASS	DC - 12.5 GHz.
8554-2521-6400	.255 MIN.	RG 401/U (.250)	STAINLESS STEEL	DC - 12.5 GHz.

male, plug, right angle, solder clamp

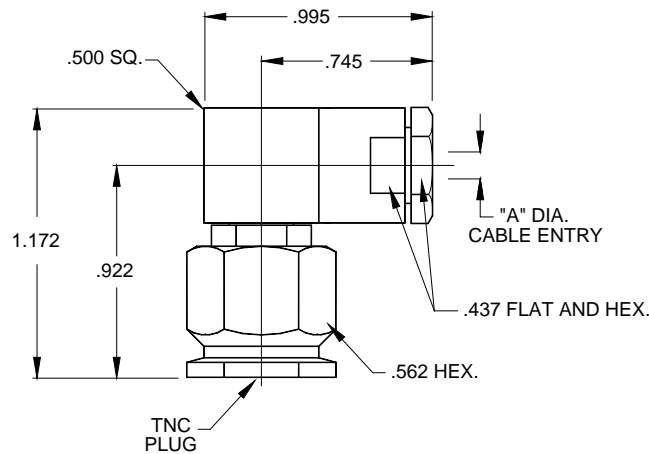

PART NUMBER	"A" DIA.	CABLE TYPE	MATERIAL TYPE	FREQUENCY RANGE
8401-8545-2700	.089 MIN.	RG 405/U (.085)	BRASS	DC - 18.0 GHz.
8401-4145-2700	.144 MIN.	RG 402/U (.141)	BRASS	DC - 18.0 GHz.
8401-8545-6200	.089 MIN.	RG 405/U (.085)	STAINLESS STEEL	DC - 18.0 GHz.
8401-4145-6200	.144 MIN.	RG 402/U (.141)	STAINLESS STEEL	DC - 18.0 GHz.
8401-2545-2700	.255 MIN.	RG 401/U (.250)	BRASS	DC - 12.5 GHz.
8401-2545-6200	.255 MIN.	RG 401/U (.250)	STAINLESS STEEL	DC - 12.5 GHz.

Specifications are subject to change without notice

TNC • flexible cable connectors

male, plug, straight, crimp attachment
rg 174/u, 179, 187, 188, 316

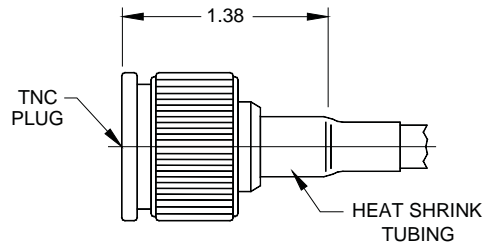

PART NUMBER	MATERIAL TYPE	FREQUENCY RANGE
8400-1631-2301	BRASS	DC - 3.0 GHz.
8400-1631-6200	STAINLESS STEEL	DC - 3.0 GHz.

male, plug, straight, crimp attachment
rg 316 double braid

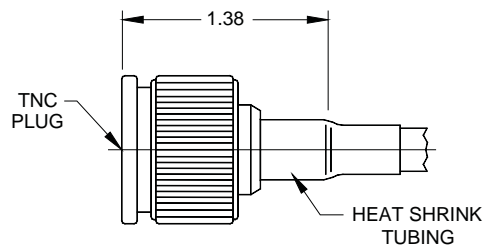

PART NUMBER	MATERIAL TYPE	FREQUENCY RANGE
8400-1830-2300	BRASS	DC - 3.0 GHz.
8400-1830-6200	STAINLESS STEEL	DC - 3.0 GHz.

male, plug, straight, crimp attachment
rg 58/u, 142, 223, 400

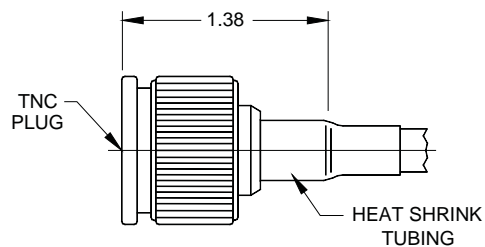

PART NUMBER	MATERIAL TYPE	FREQUENCY RANGE
8400-4230-2301	BRASS	DC - 6.0 GHz.
8400-4230-6201	STAINLESS STEEL	DC - 6.0 GHz.

Specifications are subject to change without notice

TNC • flexible cable connectors

female, jack, bulkhead, clamp attachment

rg174/u, 179, 187, 188, 316

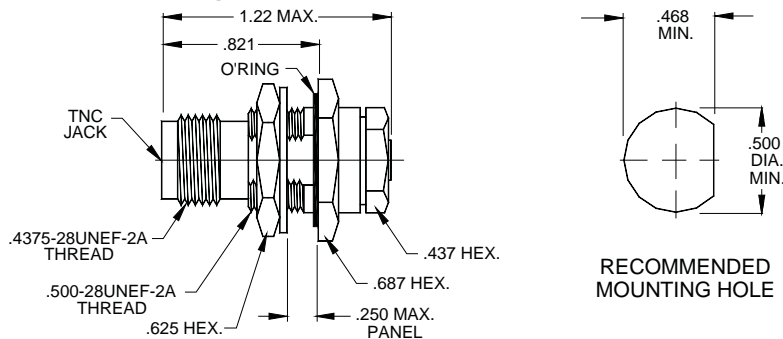

PART NUMBER	MATERIAL TYPE	FREQUENCY RANGE
8510-1631-2301	BRASS	DC - 3.0 GHz.
8510-1631-6200	STAINLESS STEEL	DC - 3.0 GHz.

female, jack, bulkhead, clamp attachment

rg316 double braid

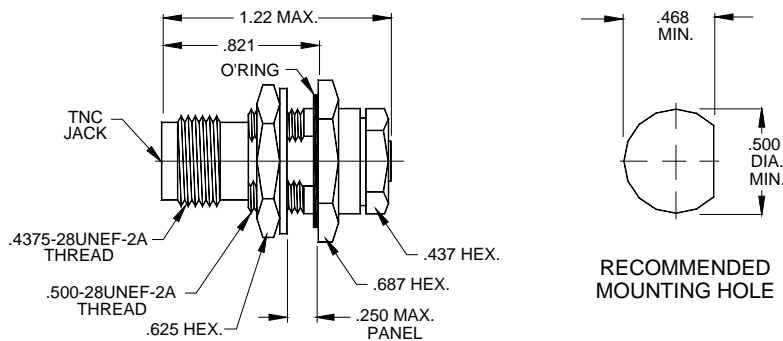

PART NUMBER	MATERIAL TYPE	FREQUENCY RANGE
8510-1830-2300	BRASS	DC - 3.0 GHz.
8510-1830-6200	STAINLESS STEEL	DC - 3.0 GHz.

female, jack, bulkhead, clamp attachment

rg55/u, 142, 223, 400

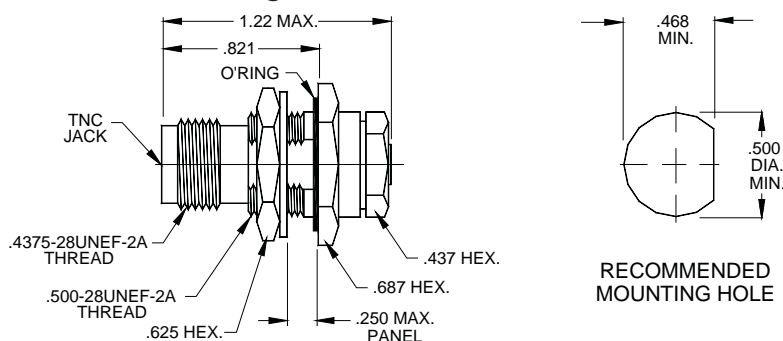

PART NUMBER	MATERIAL TYPE	FREQUENCY RANGE
8510-4230-2301	BRASS	DC - 6.0 GHz.
8510-4230-6201	STAINLESS STEEL	DC - 6.0 GHz.

Specifications are subject to change without notice

TNC • field replaceable connectors

female, jack, 4 hole flange mount

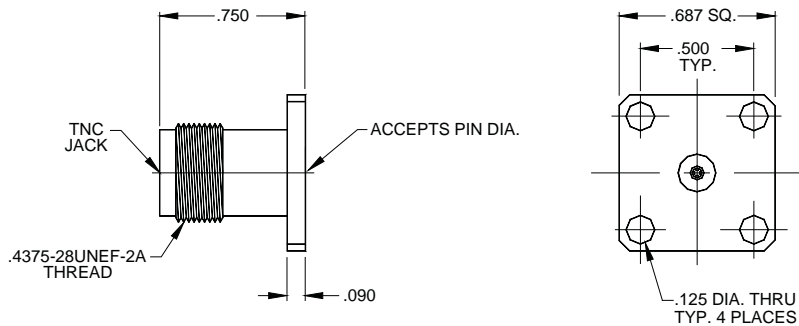

PART NUMBER	ACCEPTS PIN DIA.	MATERIAL TYPE	FREQUENCY RANGE
8554-0081-2715	.016/.011	BRASS	DC - 18.0 GHz.
8554-0081-6215	.016/.011	STAINLESS STEEL	DC - 18.0 GHz.
8554-0081-2720	.021/.017	BRASS	DC - 18.0 GHz.
8554-0081-6220	.021/.017	STAINLESS STEEL	DC - 18.0 GHz.
8554-0081-2735	.037/.035	BRASS	DC - 18.0 GHz.
8554-0081-6235	.037/.035	STAINLESS STEEL	DC - 18.0 GHz.

female, jack, 4 hole flange mount with emi gasket

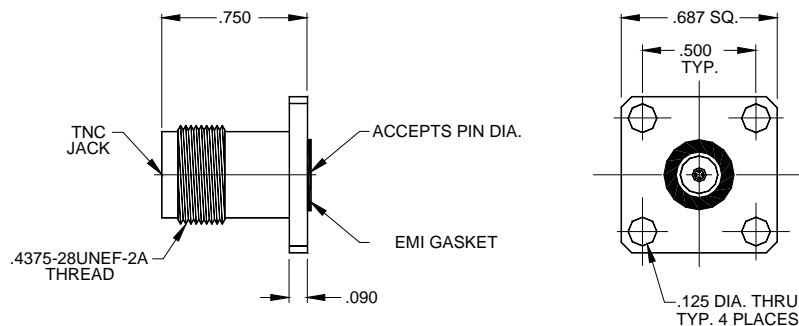

PART NUMBER	ACCEPTS PIN DIA.	MATERIAL TYPE	FREQUENCY RANGE
8554-0781-2715	.016/.011	BRASS	DC - 18.0 GHz.
8554-0781-6215	.016/.011	STAINLESS STEEL	DC - 18.0 GHz.
8554-0781-2720	.021/.017	BRASS	DC - 18.0 GHz.
8554-0781-6220	.021/.017	STAINLESS STEEL	DC - 18.0 GHz.
8554-0781-2735	.037/.035	BRASS	DC - 18.0 GHz.
8554-0781-6235	.037/.035	STAINLESS STEEL	DC - 18.0 GHz.

Specifications are subject to change without notice

TNC • field replaceable connectors

male, plug, 4 hole flange mount

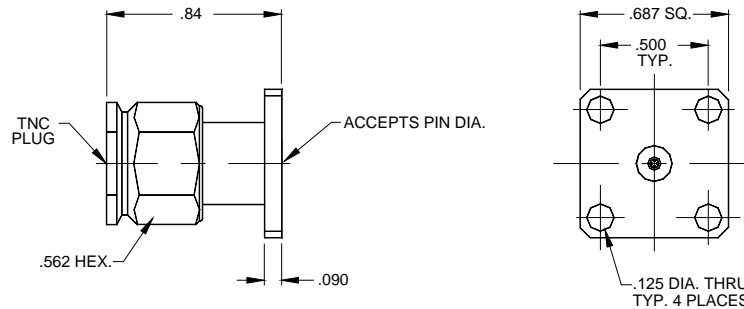

PART NUMBER	ACCEPTS PIN DIA.	MATERIAL TYPE	FREQUENCY RANGE
8454-0081-2715	.016/.011	BRASS	DC - 18.0 GHz.
8454-0081-6215	.016/.011	STAINLESS STEEL	DC - 18.0 GHz.
8454-0081-2720	.021/.017	BRASS	DC - 18.0 GHz.
8454-0081-6220	.021/.017	STAINLESS STEEL	DC - 18.0 GHz.
8454-0081-2735	.037/.035	BRASS	DC - 18.0 GHz.
8454-0081-6235	.037/.035	STAINLESS STEEL	DC - 18.0 GHz.

male, plug, 4 hole flange mount with emi gasket

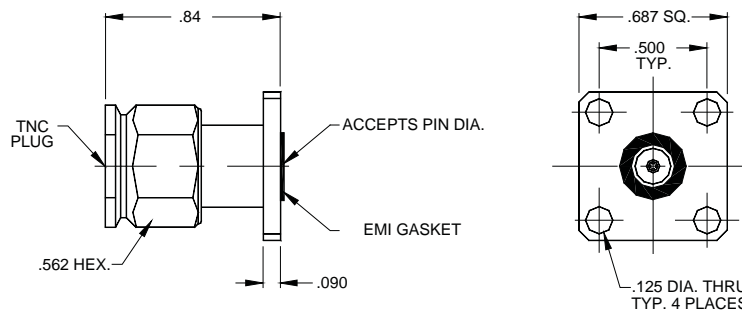

PART NUMBER	ACCEPTS PIN DIA.	MATERIAL TYPE	FREQUENCY RANGE
8454-0781-2715	.016/.011	BRASS	DC - 18.0 GHz.
8454-0781-6215	.016/.011	STAINLESS STEEL	DC - 18.0 GHz.
8454-0781-2720	.021/.017	BRASS	DC - 18.0 GHz.
8454-0781-6220	.021/.017	STAINLESS STEEL	DC - 18.0 GHz.
8454-0781-2735	.037/.035	BRASS	DC - 18.0 GHz.
8454-0781-6235	.037/.035	STAINLESS STEEL	DC - 18.0 GHz.

Specifications are subject to change without notice

TNC • field replaceable connectors

female, jack, thread-in

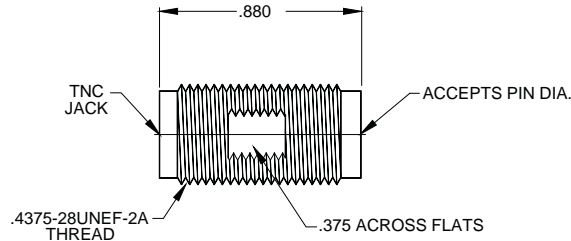

PART NUMBER	ACCEPTS PIN DIA.	MATERIAL TYPE	FREQUENCY RANGE
8530-0081-2715	.016/.011	BRASS	DC - 18.0 GHz.
8530-0081-6215	.016/.011	STAINLESS STEEL	DC - 18.0 GHz.
8530-0081-2722	.021/.017	BRASS	DC - 18.0 GHz.
8530-0081-6222	.021/.017	STAINLESS STEEL	DC - 18.0 GHz.
8530-0081-2736	.037/.035	BRASS	DC - 18.0 GHz.
8530-0081-6236	.037/.035	STAINLESS STEEL	DC - 18.0 GHz.

male, plug, thread-in

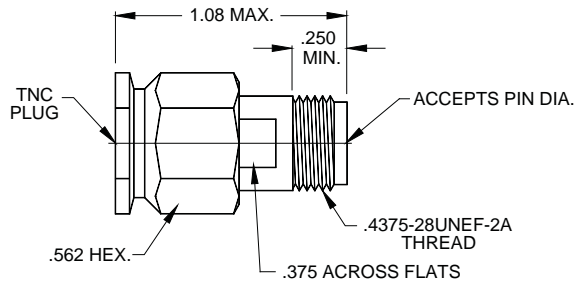

PART NUMBER	ACCEPTS PIN DIA.	MATERIAL TYPE	FREQUENCY RANGE
8430-0081-2715	.016/.011	BRASS	DC - 18.0 GHz.
8430-0081-6215	.016/.011	STAINLESS STEEL	DC - 18.0 GHz.
8430-0081-2720	.021/.017	BRASS	DC - 18.0 GHz.
8430-0081-6220	.021/.017	STAINLESS STEEL	DC - 18.0 GHz.
8430-0081-2736	.037/.035	BRASS	DC - 18.0 GHz.
8430-0081-6236	.037/.035	STAINLESS STEEL	DC - 18.0 GHz.

Specifications are subject to change without notice

TNC • hermetic connectors

female, jack, thread-in “sparkplug”

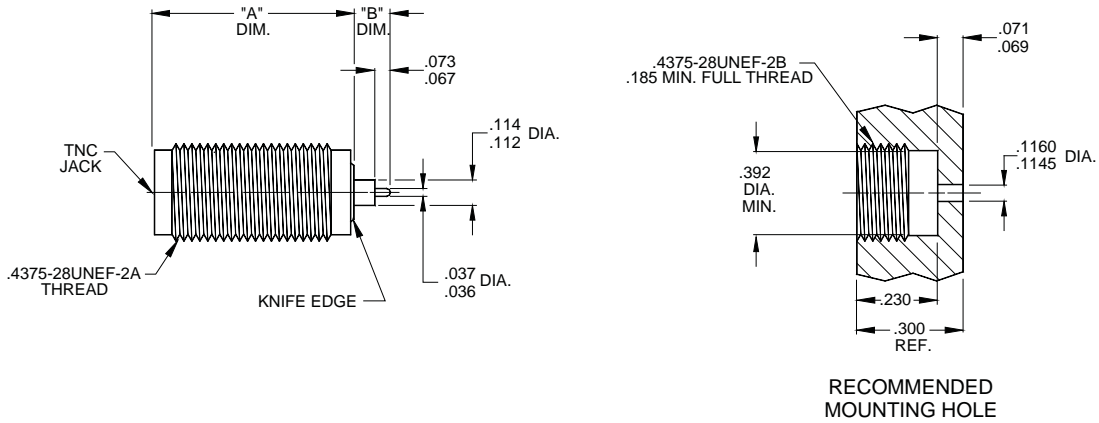

PART NUMBER	“A” DIM.	“B” DIM.	MATERIAL TYPE	FREQUENCY RANGE
8530-0431-6436	.84	.110	STAINLESS STEEL	DC - 18.0 GHz.

female, jack, thread-in, knife edge “sparkplug”, sliding contact

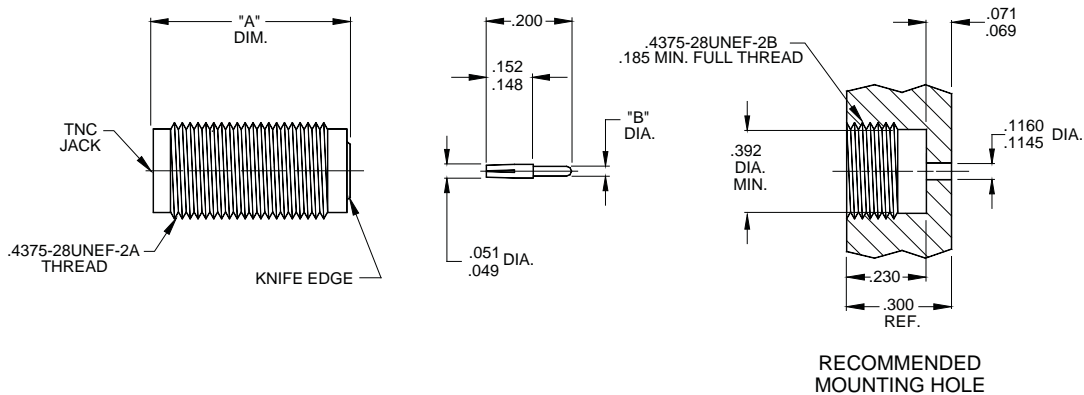

PART NUMBER	“A” DIM.	“B” DIA.	MATERIAL TYPE	FREQUENCY RANGE
8530-0441-6436	.84	.037/.035	STAINLESS STEEL	DC - 18.0 GHz.

Specifications are subject to change without notice

TNC • in-series adapters

female, jack to female, jack, straight

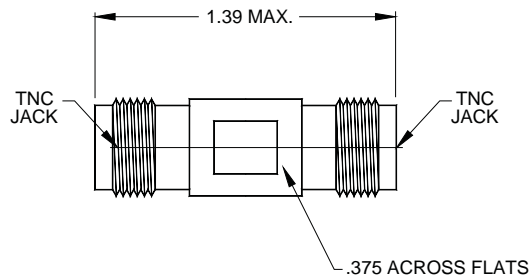

PART NUMBER	MATERIAL TYPE	FREQUENCY RANGE
1100-8585-2787	BRASS	DC - 18.0 GHz.
1100-8585-6287	STAINLESS STEEL	DC - 18.0 GHz.

male, plug to male, plug, straight

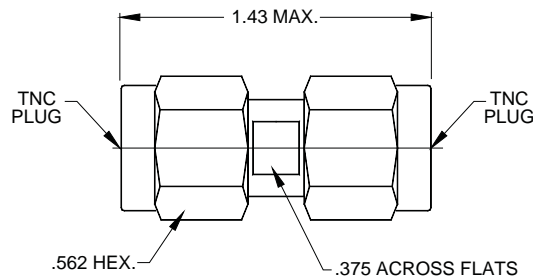

PART NUMBER	MATERIAL TYPE	FREQUENCY RANGE
1100-8484-2787	BRASS	DC - 18.0 GHz.
1100-8484-6287	STAINLESS STEEL	DC - 18.0 GHz.

male, plug to female, jack, straight

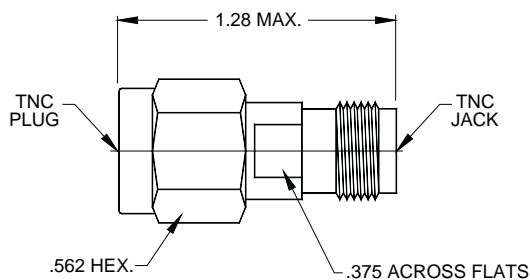

PART NUMBER	MATERIAL TYPE	FREQUENCY RANGE
1100-8485-2787	BRASS	DC - 18.0 GHz.
1100-8485-6287	STAINLESS STEEL	DC - 18.0 GHz.

Specifications are subject to change without notice