



BONITRON

Solutions for AC Drives

PRODUCT OVERVIEW

Bonitron Solutions for AC Drives

Industrial electronics have evolved greatly over the half-century that Bonitron has been in business, but one thing remains constant; Users want their drive systems and processes to be reliable and maximize productivity.

Bonitron specializes in designing accessories for variable speed drives and offers solutions ranging from Overvoltage braking solutions, such as Braking Transistors, Resistors, and Line Regeneration, to Undervoltage Solutions, such as UPD Uninterruptible Power for Drives. Other solutions include Single and 3-Phase Power Supplies, as well as Portable Capacitor Formers.

With thousands of engineered products and new solutions released regularly, visit Bonitron.com or contact your local drive distributor to learn more.

As always, 'if you have VFDs, you'll need some of these!'

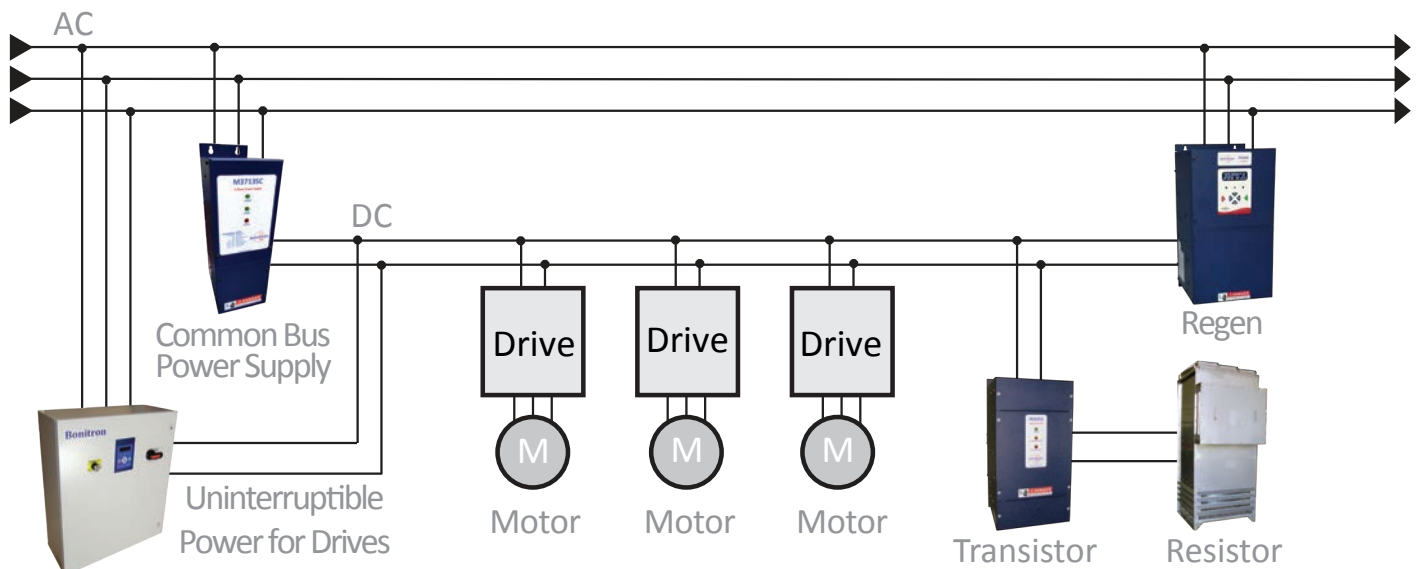
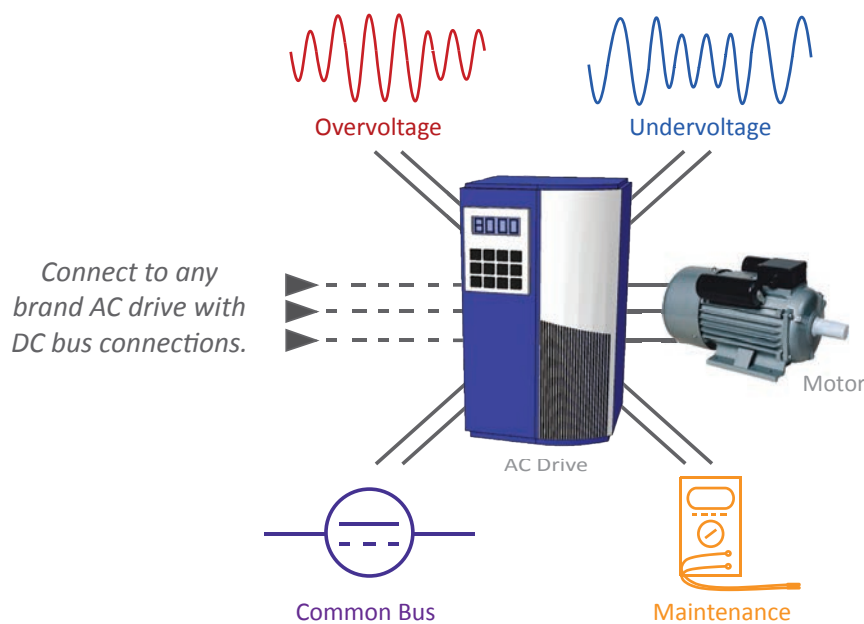
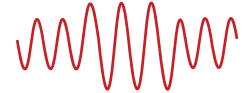

TABLE OF CONTENTS

Line Regeneration	
• M3545 & M3645.....	3 - 4
Capacitive Regeneration	
• M3800.....	5
Braking Transistors	
• M3452.....	6 - 9
• M3675T & M3575T.....	10
Braking Resistors	
• Case Resistors.....	11
• M3775R.....	12
• M3775RPF.....	13 - 14
• M3575R.....	15 - 16
Combo Units	
• M3452 Complete.....	17
Servo Motor Braking	
• M3500DB.....	18
UPD Ride-Thru Systems.....	21 - 22
UPD Ride-Thru Lite.....	23
Voltage Regulators	
• M3460R.....	24
• M3460B.....	25
• M3534.....	26
Chargers	
• M3528.....	27
Energy Storage	
• M3528B.....	28
Dischargers	
• KIT3628.....	29
Digital Display	
• KIT3660DD5.....	30
Common Bus Sharing Diodes	
• M3345CBM.....	34
Common Bus Isolation Diodes	
• M3460D.....	34
Bus Filter Capacitance	
• M3612EC & M3612RC.....	35
Regenerative DC Bus Power Supply	
• M3545P & M3645P.....	36
3-Phase Power Supplies	
• M3713.....	38 - 39
Single Phase Power Supplies	
• M3712.....	40
24VDC Power Supplies	
• M3699.....	41
• M7009.....	42
Portable Capacitor Former	
• M3628PCF.....	44
Automatic Capacitor Former	
• M362ACF.....	45
Portable Ultracapacitor Tester	
• M3628PUT.....	45
Regen Energy Monitor	
• M3660REM.....	46

Overvoltage



Undervoltage

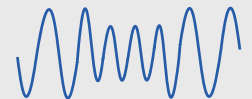

Input Power Supply
& Common Bus



Maintenance



Custom Solutions

Not only does Bonitron have standard products, but we are able to solve specific solutions for custom applications and projects.

"If you don't see what you need, call us and we'll work together to create a solution to fit your needs!"

- Keith Benson



Power Supply

- Low-Voltage Power Supply used for a streetcar/Trolley project
- Isolated 28V 250-amp battery charger
 - 700-1000VDC input to car from cantenary
- Boost from 24V battery string to operate drives during outage
- Relatively low power of 7kW



3-phase Power Supply

- Replacement Power Supply for amusement park
- 230VAC three-phase input
- 100ADC output
- Integrated braking transistor



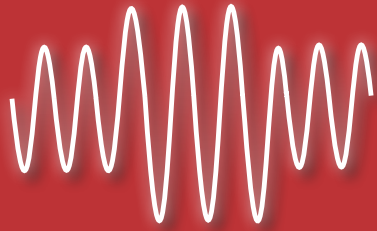

Overvoltage Solutions

Line Regeneration

- M3545
- M3645

Capacitive Regen

- M3800

Braking Transistors

- M3452
- M3675T
- M3575T

Braking Resistors

- Case Resistors
- M3775RPF
- M3575R
- M3775R

Combo Units

- M3452 Complete

Servo Motor Braking

- M3500DB



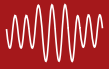

Understanding Braking Conditions

Overhauling

An overhauling load requires braking to keep the motor from increasing speed beyond the speed set by the drive. The required braking torque remains constant and approximately twice the power of deceleration braking is required.

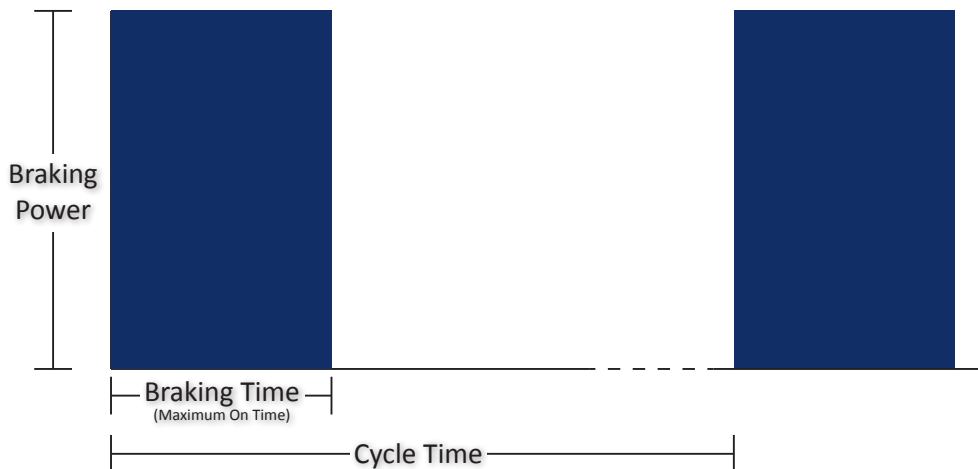

$$\text{Overhauling Duty} = \frac{\text{Braking Time}}{\text{Cycle Time}}$$

Deceleration

During deceleration, braking is required to stop or reduce the speed of the motor. The required braking torque reduces with speed and approximately half the power of braking an overhauling load is required.

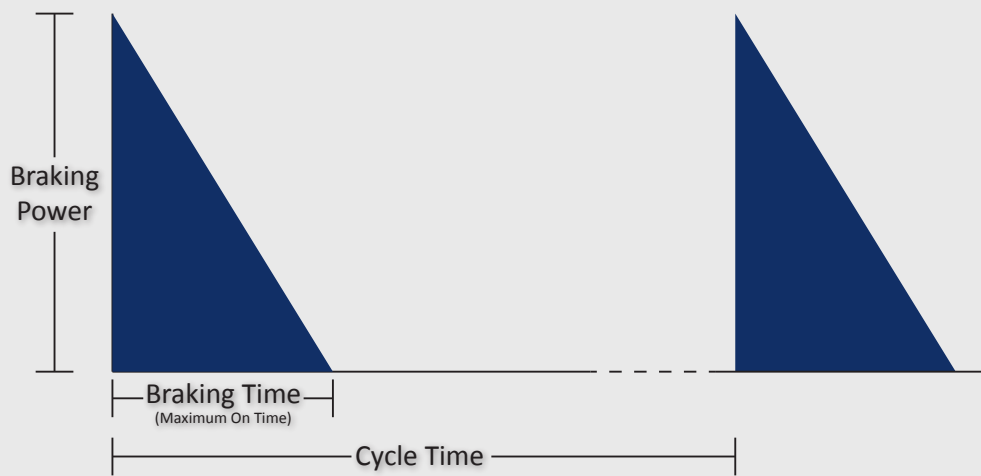

$$\text{Deceleration Duty} = \frac{\text{Braking Time}}{\text{Cycle Time}}$$



Line Regeneration

M3545 & M3645



M3645
Series



M3545
Series

Bonitron Line Regens replace traditional braking transistor and resistor options that waste energy as heat during drive braking. Instead of dissipating braking energy as heat in a resistor, Line Regen solutions return this energy to the power grid. This reduces demand from the utility, which equates to ample energy savings.

The Bonitron Line Regen is efficient and small enough to be integrated into the drive cabinet. This eliminates excess resistor wiring and cooling costs.



Display & Indicators	LED Indicators			Interactive Display Screens		
	Power	Regen Active	Not Ready	Metering	Energy Records	Fault Records
M3545 Series	●	●	●			
M3645 Series <small>with -D in Model Number</small>	●	●	●	●	●	●

Metering

- DC Voltage
- DC Regen Current
- Regen Power
- Total Unit On-time

Energy Records

- Energy Regenerated in Lifetime
- Energy Regenerated since user reset

Fault Records

- Stores 50 most recent fault states (Last one record is stored with LED Indicators)
- Feedback Undervoltage, Overtemperature, DC Overvoltage, Differential Overvoltage, Sync Loss, IGBT Driver, Phase Overcurrent, Phase Loss, DC Undervoltage, Precharge Failure, Frequency Detect Failure

Savings Calculator

Bonitron Line Regen units return regenerative energy back to the AC line where it can be used by equipment within the facility. This reduces the amount of power required from the utility; reducing utility costs.

The formula to the right is an example for a 100HP application. Visit Bonitron.com/RegenCalculator to see your potential savings.

The calculator does not include the cost of the Line Regen itself. Contact Bonitron for pricing and to discuss your application. When comparing a Line Regen to a Resistor, consider the added cost of wiring, conduit, or cooling for a resistor. While many resistors produce enough heat that they need to be located outside, Bonitron Line Regens are 99% efficient and are designed to be integrated into the drive cabinet.

Bonitron.com/RegenCalculator

Formula:	Example:
(Continuous HP)	(100)
x (Duty Cycle %)	x (0.40)
x (Days of Operation)	x (350)
x (Hours of Operation per Day)	x (12)
x (Cost per kWh)	x (0.10)
<u>x (0.746)</u>	<u>x (0.746)</u>
= Savings	= \$12,527.76

*Contact Bonitron to discuss your application's possible savings.



www.bonitron.com



615-244-2825

info@bonitron.com



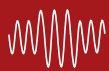

Overvoltage Solutions

Series Selection	System Voltage	Current (Continuous)	Current (Peak)	Single Phase Operation*	UL Listed	Interactive Display
M3545 Series	208 - 480VAC	2A - 15A	3A - 22.5A	●	● 15A Only	
M3645 Series	208 - 600VAC	30 - 300A	45 - 375A		●	●

*See table below for single phase ratings

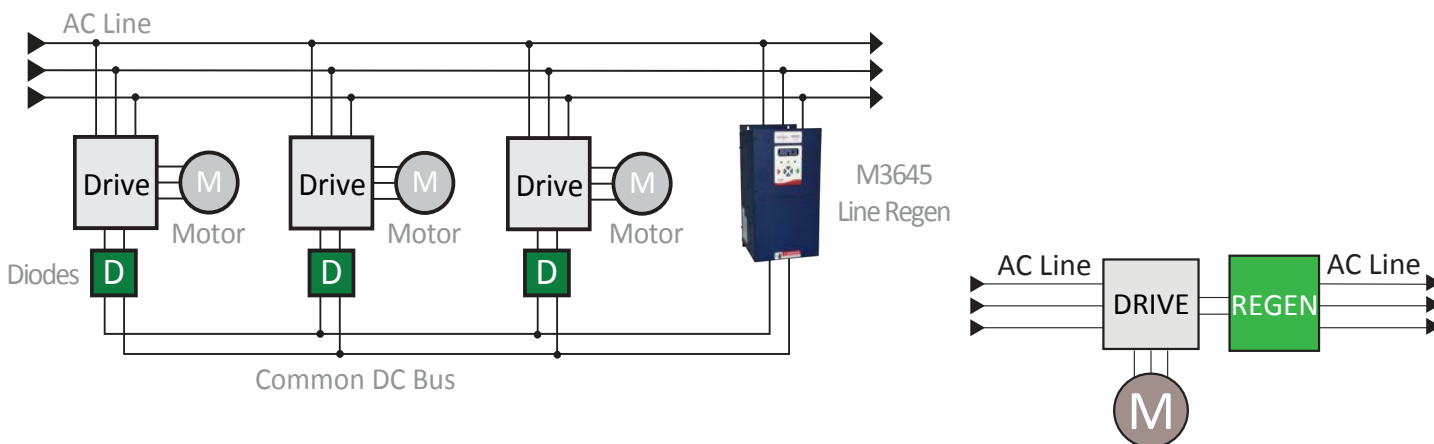

*The M3645-X300R is required with the M3645-X300T-M15-X modules.

Phase	Line Regen							Fuse Plate Model Number	Reactor Model Number	
	Power		Display Type	Model Number	Current		Watt Loss			
	Cont.	Peak			Cont.	Peak				
208 - 240VAC										
1	0.9 HP	1.4 HP	LEDs	M3545-L006-M4	2 A	3 A	34 W	14.80" x 4.00" x 8.30"	M3545F-H015	N/A
3	2.8 HP	4.2 HP			6 A	9 A	59 W			
1	2.25 HP	3.5 HP			LEDs	M3545-L015-M4	5 A			
3	7 HP	10.5 HP	15 A	22.5 A			117W			
3	14 HP	21 HP	30 A	45 A			180W	20.00" x 10.00" x 10.10"		
3	24 HP	36 HP	LEDs+Digital	M3645-L030-M10-D	50 A	75 A	265W	22.00" x 11.30" x 10.60"	M3645F-H050	
3	48 HP	72 HP	LEDs+Digital	M3645-L100-M12-D	100 A	150 A	470W	24.00" x 12.00" x 12.10"	M3645F-H100	
3	72 HP	108 HP	LEDs+Digital	M3645-L150T-M15-D	150 A	225 A	1000W	26.00" x 13.90" x 11.11"	M3645F-H150	M3645-L150R
3	108 HP	160.8 HP	LEDs+Digital	M3645-L225T-M15-D	225 A	335 A	1500W	26.00" x 13.90" x 11.11"	M3645F-H225	M3645-L225R
3	96 HP	120 HP	LEDs+Digital	M3645-L300T-M15-D	300 A	375 A	2000W	26.00" x 13.90" x 11.11"	M3645F-H300	M3645-L300R
380 - 415VAC										
3	25 HP	37 HP	LEDs+Digital	M3645-E030-M10-D	30 A	45 A	180W	20.00" x 10.00" x 10.10"	M3645F-H030	
3	41 HP	62 HP	LEDs+Digital	M3645-E050-M11-D	50 A	75 A	265W	22.00" x 11.30" x 10.60"	M3645F-H050	N/A
3	83 HP	125 HP	LEDs+Digital	M3645-E100-M12-D	100 A	150 A	470W	24.00" x 12.00" x 12.10"	M3645F-H100	
3	125 HP	187.5 HP	LEDs+Digital	M3645-E150T-M15-D	150 A	225 A	1000W	26.00" x 13.90" x 11.11"	M3645F-H225	M3645-E150R
3	187.5 HP	279.2 HP	LEDs+Digital	M3645-E225T-M15-D	225 A	335 A	1500W	26.00" x 13.90" x 11.11"	M3645F-H300	M3645-E225R
3	250 HP	312.5 HP	LEDs+Digital	M3645-E300T-M15-D	300 A	375 A	2000W	26.00" x 13.90" x 11.11"	M3645F-H300	M3645-E300R
460 - 480VAC										
1	1.8 HP	2.8 HP	LEDs	M3545-H006-M4	2 A	3 A	34 W	14.80" x 4.00" x 8.30"	M3545F-H015	N/A
3	5.6 HP	8.4 HP			6 A	9 A	59 W			
1	4.5 HP	7 HP			LEDs	M3545-H015-M4	5 A			
3	14 HP	21 HP	15 A	22.5 A			117W			
3	28 HP	43 HP	30 A	45 A			180W	20.00" x 10.00" x 10.10"		
3	48 HP	72 HP	LEDs+Digital	M3645-H030-M10-D	50 A	75 A	265W	22.00" x 11.30" x 10.60"	M3645F-H050	
3	96 HP	144 HP	LEDs+Digital	M3645-H100-M12-D	100 A	150 A	470W	24.00" x 12.00" x 12.10"	M3645F-H100	
3	144 HP	216 HP	LEDs+Digital	M3645-H150T-M15-D	150 A	225 A	1000W	26.00" x 13.90" x 11.11"	M3645F-H150	M3645-H150R
3	216 HP	321.6 HP	LEDs+Digital	M3645-H225T-M15-D	225 A	335 A	1500W	26.00" x 13.90" x 11.11"	M3645F-H225	M3645-H225R
3	288 HP	360 HP	LEDs+Digital	M3645-H300T-M15-D	300 A	375 A	2000W	26.00" x 13.90" x 11.11"	M3645F-H300	M3645-H300R
575 - 600VAC										
3	36 HP	54 HP	LEDs+Digital	M3645-C030-M10-D	30 A	45 A	180W	20.00" x 10.00" x 10.10"	M3645F-C030	
3	60 HP	90 HP	LEDs+Digital	M3645-C050-M11-D	50 A	75 A	265W	22.00" x 11.30" x 10.60"	M3645F-C050	N/A
3	120 HP	180 HP	LEDs+Digital	M3645-C100-M12-D	100 A	150 A	470W	24.00" x 12.00" x 12.10"	M3645F-C100	



Overvoltage Solutions

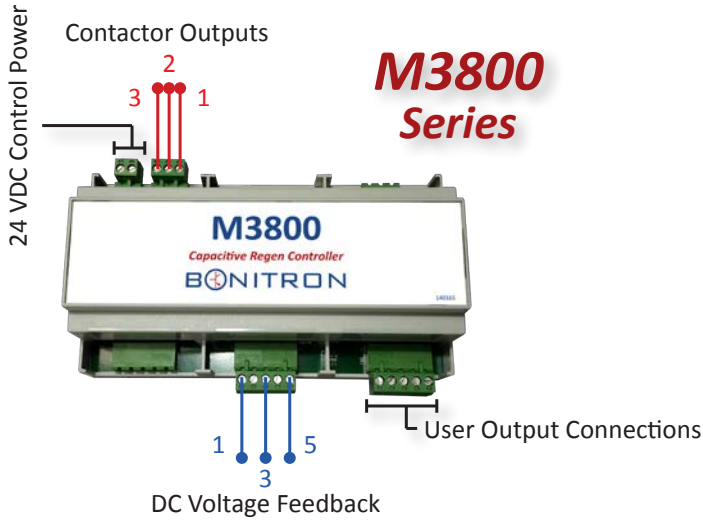

Bonitron’s Capacitive Regen Controller is a simple, passive method for storing regenerated energy from a braking motor, well suited for cyclic applications. The M3800 Capacitive Regen Controller, used in conjunction with a capacitor bank and various external components, allows for an increase in energy storage with a smaller rise in DC bus voltage. This stored energy can then be sourced back onto the DC bus during periods of higher demand, lowering the peak power required by the drive system.

To avoid the possibility that the capacitor bank could rise to a DC level that can cause an overvoltage trip on the drive, a braking chopper should be used in conjunction with the Capacitive Regen Controller.

System Layout

The M3800 Controller, as part of a Capacitive Regen system, requires several external components. Please see below for a diagram of the expected external system layout.

Storage

The capacitors must be sized according to the voltage and joule requirements of the application. They must be able to absorb the regenerated energy from the drive and keep the voltage below the drive’s overvoltage fault level.

Pre-charge

The M3800 must be able to pre-charge the storage bank before it can connect to the drive bus; for this, it needs a rectifier and resistor, with a contactor to control them.

Discharge

The same resistors can be used to discharge the capacitor bank. There also needs to be a contactor in the discharge path, however this one should be a Normally Closed contactor. This way, if power is removed from the system, it automatically discharges the capacitor bank to a safe voltage.

Output to Drive

The output contactor must be rated for the max DC bus voltage as well as the max expected regen current.

External Components for the M3800 Controller

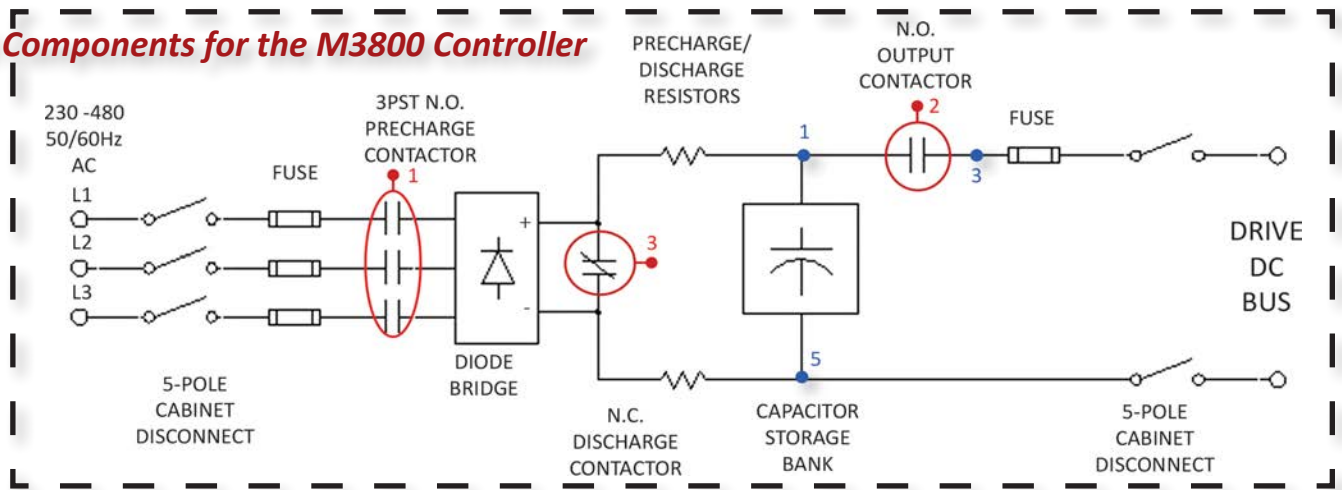

Model Number	Description 1	Capacitor Storage	Dimensions (H x W x D)	Supply Voltage
208- 480VAC 750VDC				
M3800-H01	Capacitive Regen Controller	Unlimited	4.20 x 6.22 x 2.28"	24VDC





Overvoltage Solutions

Bonitron remains a leader in the field of high horsepower braking and proudly maintains its reputation for durability and reliability, with models rated up to 1600A.

Bonitron Braking Transistors are used with AC drives to allow full power braking and eliminate overvoltage faults. This permits controlled braking and dramatically shortens motor stopping time. The M3452 works with Variable Speed Drives (VSDs) to monitor the DC bus. If overvoltage occurs, the M3452 shunts the excess energy through a braking resistor to prevent overvoltage faults. (Standard and custom braking resistors are also available from Bonitron. For more information see the M3775R series).

Optional advanced diagnostics allow for remote monitoring, while local indicators assist in pinpointing issues. Remote configuration and networking capabilities add to the flexibility and reliability of your overall system and reduce your installation wiring.



Up to 1600A
per unit

M3452 Series

50 - 100% Braking Duty

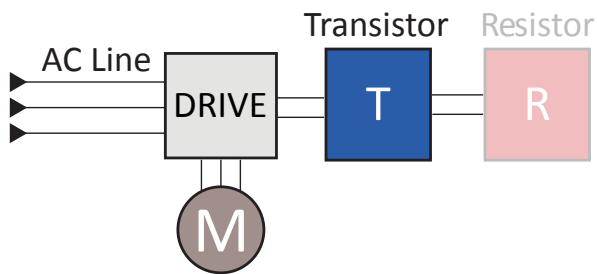

Product Highlights

- Local and remote status monitoring
- EtherNet/IP™ & PROFIBUS™ DP networking options
- Systems can be reconfigured on-the-fly
- Up to 1600A per unit (Parallel operation for higher ratings)
- Proven record for quality and support

Model Number Breakdown

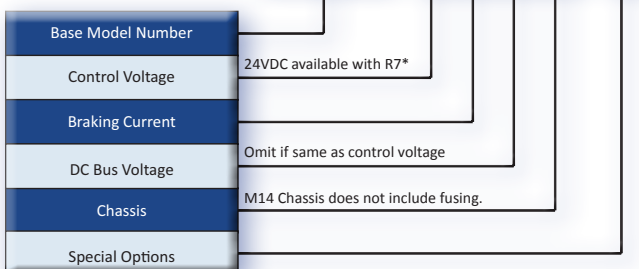

Specifications

Voltages.....230 - 690VAC
Current Rating.....75 to 1600Amps
Connections.....Drive DC Bus
 Input AC Line (Control)
 Ground
Max. 'On-Time'.....Peak rating for 60 seconds
 Continuous rating - continuous





LISTED

when used with

A, R5, R7, R7E, R7EIP/PDP control options. Not "E" voltage class, 800A, 1200A, or units with the T10 chassis



230-240VAC

Power (Peak)	Control Voltage	Base Model Number	Braking Current (Peak)	Braking Current (RMS)	Minimum Resistance	Dimensions (H x W x D)	UL and CUL Listing
230-240 VAC Drives 375 VDC Setpoint							
37.5 HP	115-120 VAC 230-240 VAC	M3452-U75LB7 M3452-L75B7	75 A	75 A	5.00 Ω	17.75" x 7.00" x 8.10"	UL and CUL
75 HP	115-120 VAC 230-240 VAC	M3452-U150LB7 M3452-L150B7	150 A	150 A	2.50 Ω	17.75" x 7.00" x 8.10"	UL and CUL
100 HP	115-120 VAC 230-240 VAC	M3452-U200LK6 M3452-L200K6	200 A	200 A	1.90 Ω	20.00" x 7.12" x 10.50"	UL and CUL
150 HP	115-120 VAC 230-240 VAC	M3452-U300LK6 M3452-L300K6	300 A	300 A	1.25 Ω	20.00" x 7.12" x 10.50"	UL and CUL
300 HP	115-120 VAC 230-240 VAC	M3452-U600LK6 M3452-L600K6	600 A	300 A	0.63 Ω	20.00" x 7.12" x 10.50"	UL and CUL
400 HP	115-120 VAC 230-240 VAC	M3452-U800LK9 M3452-L800K9	800 A	400 A	0.47 Ω	20.00" x 9.05" x 10.25"	
600 HP	115-120 VAC 230-240 VAC	M3452-U1200LK10 M3452-L1200K10	1200 A	600 A	0.32 Ω	20.00" x 10.00" x 10.50"	

For 24VDC control voltage, replace "U" with "D". Only available with R7, R7E Options. (Not UL Listed)

380-415VAC

Power (Peak)	Control Voltage	Base Model Number	Braking Current (Peak)	Braking Current (RMS)	Minimum Resistance	Dimensions (H x W x D)	UL and CUL Listing
380 - 415 VAC Drives 620 VDC Setpoint							
62.5 HP	120 VAC 380 VAC	M3452-U75EB7 M3452-E75B7	75 A	75 A	8.27 Ω	17.75" x 7.00" x 8.10"	
125 HP	120 VAC 380 VAC	M3452-U150EB7 M3452-E150B7	150 A	150 A	4.13 Ω	17.75" x 7.00" x 8.10"	
160 HP	120 VAC 380 VAC	M3452-U200EK6 M3452-E200K6	200 A	200 A	3.10 Ω	20.00" x 7.12" x 10.50"	
240 HP	120 VAC 380 VAC	M3452-U300EK6 M3452-E300K6	300 A	300 A	2.07 Ω	20.00" x 7.12" x 10.50"	
490 HP	120 VAC 380 VAC	M3452-U600EK6 M3452-E600K6	600 A	300 A	1.04 Ω	20.00" x 7.12" x 10.50"	
660 HP	120 VAC 380 VAC	M3452-U800EK9 M3452-E800K9	800 A	400 A	0.78 Ω	20.00" x 9.05" x 10.25"	
1000 HP	120 VAC 380 VAC	M3452-U1200EK10 M3452-E1200K10	1200 A	600 A	0.52 Ω	20.00" x 10.00" x 10.50"	
1330 HP	120 VAC 380 VAC	M3452-U1600EM14 M3452-E1600M14	1600 A	1200 A	0.39 Ω	28.00" x 13.90" x 14.60"	
1330 HP	120 VAC 380 VAC	M3452-U1600ET10 M3452-E1600T10	1600 A	1200 A	0.39 Ω	30.59" x 10.12" x 19.18"	



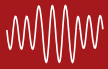

Overvoltage Solutions



LISTED

when used with

A, R5, R7, R7E, R7EIP/PDP

control options. Not "E" voltage class,
800A, 1200A, or units with the T10 chassis

460-480VAC

Power (Peak)	Control Voltage	Base Model Number	Braking Current (Peak)	Braking Current (RMS)	Minimum Resistance	Dimensions (H x W x D)	UL and CUL Listing
460-480 VAC Drives 750 VDC Setpoint							
75 HP	120 VAC	M3452-U75HB7	75 A	75 A	10.00 Ω	17.75" x 7.00" x 8.10"	UL and CUL
	460 VAC	M3452-H75B7					
150 HP	120 VAC	M3452-U150HB7	150 A	150 A	5.00 Ω	17.75" x 7.00" x 8.10"	UL and CUL
	460 VAC	M3452-H150B7					
200 HP	120 VAC	M3452-U200HK6	200 A	200 A	3.80 Ω	20.00" x 7.12" x 10.50"	UL and CUL
	460 VAC	M3452-H200K6					
300 HP	120 VAC	M3452-U300HK6	300 A	300 A	2.50 Ω	20.00" x 7.12" x 10.50"	UL and CUL
	460 VAC	M3452-H300K6					
600 HP	120 VAC	M3452-U600HK6	600 A	300 A	1.25 Ω	20.00" x 7.12" x 10.50"	UL and CUL
	460 VAC	M3452-H600K6					
800 HP	120 VAC	M3452-U800HK9	800 A	400 A	0.93 Ω	20.00" x 9.05" x 10.25"	
	460 VAC	M3452-H800K9					
1200 HP	120 VAC	M3452-U1200HK10	1200 A	600 A	0.63 Ω	20.00" x 10.00" x 10.50"	
	460 VAC	M3452-H1200K10					
1600 HP	120 VAC	M3452-U1600HM14	1600 A	1200 A	0.47 Ω	28.00" x 13.90" x 14.60"	UL and CUL
	460 VAC	M3452-H1600M14					
1600 HP	120 VAC	M3452-U1600HT10	1600 A	1200 A	0.47 Ω	30.59" x 10.12" x 19.18"	
	460 VAC	M3452-H1600T10					

For 24VDC control voltage, replace "U" with "D". Only available with R7, R7E Options. (Not UL Listed)

575-600VAC

Power (Peak)	Control Voltage	Base Model Number	Braking Current (Peak)	Braking Current (RMS)	Minimum Resistance	Dimensions (H x W x D)	UL and CUL Listing
575-600 VAC Drives 940 VDC Setpoint							
95 HP	120 VAC	M3452-U75CB7	75 A	75 A	12.50 Ω	17.75" x 7.00" x 8.10"	UL and CUL
	575 VAC	M3452-C75B7					
190 HP	120 VAC	M3452-U150CB7	150 A	150 A	6.30 Ω	17.75" x 7.00" x 8.10"	UL and CUL
	575 VAC	M3452-C150B7					
250 HP	120 VAC	M3452-U200CK6	200 A	200 A	4.70 Ω	20.00" x 7.12" x 10.50"	UL and CUL
	575 VAC	M3452-C200K6					
380 HP	120 VAC	M3452-U300CK6	300 A	300 A	3.20 Ω	20.00" x 7.12" x 10.50"	UL and CUL
	575 VAC	M3452-C300K6					
760 HP	120 VAC	M3452-U600CK6	600 A	300 A	1.60 Ω	20.00" x 7.12" x 10.50"	UL and CUL
	575 VAC	M3452-C600K6					
1000 HP	120 VAC	M3452-U800CK9	800 A	400 A	1.20 Ω	20.00" x 9.05" x 10.25"	
	575 VAC	M3452-C800K9					
1500 HP	120 VAC	M3452-U1200CK10	1200 A	600 A	0.78 Ω	20.00" x 10.00" x 10.50"	
	575 VAC	M3452-C1200K10					
2015 HP	120 VAC	M3452-U1600CM14	1600 A	1200 A	0.58 Ω	28.00" x 13.90" x 14.60"	UL and CUL
	575 VAC	M3452-C1600M14					
2015 HP	120 VAC	M3452-U1600CT10	1600 A	1200 A	0.58 Ω	30.59" x 10.12" x 19.18"	
	575 VAC	M3452-C1600T10					





Network and Control Options

Control Options	A	R5	R7	R7E	R7EIP	R7PDP	R7PNET
Inputs							
Enable			W	W	IC	IC	IC
Master/Slave			W	W	IC	IC	IC
Bus Discharge			W	W	IC	IC	IC
Fault Reset			W	W	IC	IC	IC
Outputs							
Module Ready	W						
Logic Power OK		W			IC	IC	IC
Not IGBT Open		W					
Not IGBT Shorted		W		W	IC	IC	IC
Not Overtemp		W		W	IC	IC	IC
Not Blown Fuse		W		W	IC	IC	IC
Control Ready			W	W			
Master/Slave Status			W	W	IC	IC	IC
Power Stage Ready			W	W			
Not Overcurrent			W	W	IC	IC	IC
Blink Codes			●	●	●	●	●



M3452
Series

EtherNet/IP is registered trademark of ODVA. PROFIBUS is a registered trademark of PROFIBUS Trade Organization.



Discrete Hardwire Connection



Ethernet Network Connection



Profibus Network Connection



Profinet Network Connection

- 75 - 150A (B7) Options Available with "A" Only
- 1200A (K10) and 1600A (M14) Options R5, R7, R7E, R7EIP, R7PDP, R7PNET
- 1600A (T10) Options R7, R7E, R7EIP, R7PDP, R7PNET
- All units above 200A have Master/Slave capability

690VAC

Power (Peak)	Control Voltage	Base Model Number	Braking Current (Peak)	Braking Current (RMS)	Minimum Resistance	Dimensions (H x W x D)	UL and CUL Listing
690 VAC Drives 1090 VDC Setpoint							
110 HP	120 VAC	M3452-U75YB7	75 A	75 A	14.50 Ω	17.75" x 7.00" x 8.10"	
220 HP	120 VAC	M3452-U150YB7	150 A	150 A	7.30 Ω	17.75" x 7.00" x 8.10"	
300 HP	120 VAC	M3452-U200YK6	200 A	200 A	5.50 Ω	20.00" x 7.12" x 10.50"	
440 HP	120 VAC	M3452-U300YK6	300 A	300 A	3.60 Ω	20.00" x 7.12" x 10.50"	
875 HP	120 VAC	M3452-U600YK6	600 A	300 A	1.95 Ω	20.00" x 7.12" x 10.50"	
1170 HP	120 VAC	M3452-U800YK9	800 A	400 A	1.40 Ω	20.00" x 9.05" x 10.25"	
1750 HP	120 VAC	M3452-U1200YK10	1200 A	600 A	0.91 Ω	20.00" x 10.00" x 10.50"	
2300 HP	120 VAC	M3452-U1600YM14	1600 A	1200 A	0.68 Ω	28.00" x 13.90" x 14.60"	



www.bonitron.com



615-244-2825

info@bonitron.com





Overvoltage Solutions

Bonitron Braking Transistors are used with AC drives to allow full power braking and eliminate overvoltage faults. This permits controlled braking and dramatically shortens motor stopping time. **The M3575T and M3675T series are ideal for drives with no internal braking transistor** and work with variable frequency drives to monitor the DC bus. If overvoltage occurs, the braking transistor shunts the excess energy through a braking resistor to **prevent overvoltage faults**.



M3575T Series



M3675T Series

20% Braking Duty

	Peak HP	Model Number	Peak Current	Cont. Current	Min. Resistance	Dimensions (H x W x D)	UL and CUL Listing
115 - 120VAC 190 VDC Setpoint							
	2.5HP	M3675T-U10	10A	2A	19Ω	7.00" x 2.06" x 6.75"	
230 - 240VAC 375VDC Setpoint							
	5HP	M3675T-L10	10A	2A	38Ω	7.00" x 2.06" x 6.75"	
	8HP	M3575T-L15	15A	3.8A	25Ω	12.75" x 3.00" x 8.70"	UL and CUL
	15HP	M3575T-L30	30A	7.75A	12.5Ω	12.75" x 3.00" x 8.70"	UL and CUL
	30HP	M3575T-L60	60A	15A	6.25Ω	12.75" x 4.00" x 8.70"	UL and CUL
	63HP	M3575T-L125	125A	32A	3Ω	17.75" x 6.50" x 8.00"	
	75HP	M3575T-L150	150A	38A	2.5Ω	17.75" x 6.50" x 8.00"	
	100HP	M3575T-L200	200A	51A	1.9Ω	17.75" x 7.00" x 8.00"	
	150HP	M3575T-L300	300A	77A	1.3Ω	17.75" x 7.00" x 8.00"	
	300HP	M3575T-L600	600A	155A	0.7Ω	17.75" x 7.00" x 8.00"	
380 - 415VAC 620VDC Setpoint							
	7.5HP	M3675T-E10	10A	2A	62Ω	7.00" x 2.06" x 6.75"	
	12.5HP	M3575T-E15	15A	3.8A	41.25Ω	12.75" x 3.00" x 8.70"	
	25HP	M3575T-E30	30A	7.75A	20.5Ω	12.75" x 3.00" x 8.70"	
	63HP	M3575T-E75	75A	19A	8.25Ω	12.75" x 4.00" x 8.70"	
	100HP	M3575T-E125	125A	32A	5Ω	17.75" x 6.50" x 8.00"	
	125HP	M3575T-E150	120A	38A	4.1Ω	17.75" x 6.50" x 8.00"	
	165HP	M3575T-E200	200A	51A	3.1Ω	17.75" x 7.00" x 8.00"	
	240HP	M3575T-E300	300A	77A	2Ω	17.75" x 7.00" x 8.00"	
	530HP	M3575T-E600	600A	155A	1.1Ω	17.75" x 7.00" x 8.00"	
460 - 480VAC 750VDC Setpoint							
	10HP	M3675T-H10	10A	2A	75Ω	7.00" x 2.06" x 6.75"	
	15HP	M3575T-H15	15A	3.8A	50Ω	12.75" x 3.00" x 7.70"	UL and CUL
	30HP	M3575T-H30	30A	7.75A	25Ω	12.75" x 3.00" x 7.70"	UL and CUL
	75HP	M3575T-H75	75A	19A	10Ω	12.75" x 4.00" x 7.70"	UL and CUL
	125HP	M3575T-H125	125A	32A	6Ω	17.75" x 6.50" x 8.00"	
	150HP	M3575T-H150	150A	38A	5Ω	17.75" x 6.50" x 8.00"	
	200HP	M3575T-H200	200A	51A	3.75Ω	17.75" x 7.00" x 8.00"	
	300HP	M3575T-H300	300A	77A	2.5Ω	17.75" x 7.00" x 8.00"	
	600HP	M3575T-H600	600A	155A	1.25Ω	17.75" x 7.00" x 8.00"	



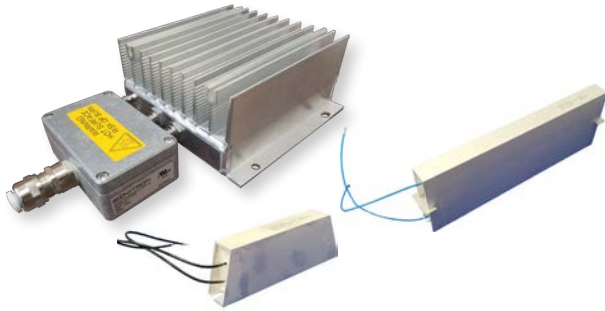

Case Resistors

Bonitron now offers case resistors for applications up to 20 HP, which are a great add-on solution due to their small size and cost.

Like the rest of Bonitron’s resistor offering, Case Resistors protect drives from overvoltage faults by dissipating excess regenerative energy as heat. Case Resistors are used in applications where infrequent, low duty cycle, or low horsepower regeneration occurs.

Case resistors are commonly used with a drive’s internal brake or a Bonitron M3675T Braking Transistor.

For resistors rated up to the megawatts, see the Bonitron M3575R or M3775R Series. Custom resistors are also available.

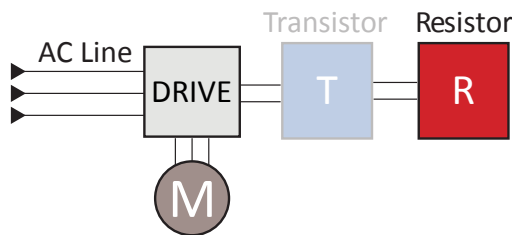

Product Highlights

1 - 20 HP

- UL & CUL Listed
- Aluminium housing
- Two-screw mounting
- Installable with new application or as retrofit
- Rapid installation increases up time

	Power			Resistance (Ohms)	Required Model Number(s)	
	Peak HP	Peak	Cont.		Model Number	Dimensions (HxWxD)
230 - 240VAC						
	1	1125 W	56 W	125	RS CRL001HP	165 x 30 x 60mm
IP 54	1	1125 W	150 W	125	RS CRML001HP-54	167 x 30 x 60mm
IP 66	1	1125 W	600 W	125	RS CRML001HP-66JB-T	285 x 174 x 75mm
	2	2250 W	112 W	62.5	RS CRL002HP	265 x 30 x 60mm
IP 54	2	2250 W	168 W	62.5	RS CRML002HP-54	267 x 30 x 60mm
IP 66	2	2250 W	600 W	62.5	RS CRML002HP-66JB-T	285 x 175 x 75mm
	10	5625 W	281 W	25	RS CRL005HP	335 x 59 x 61mm
IP 54	5	5625 W	800 W	25	RS CRML005HP-54	337 x 45 x 120mm
IP 66	5	5625 W	600 W	25	RS CRML005HP-66JB-T	285 x 174 x 75mm
IP 66	10	11250 W	1200 W	12.5	RS CRML010HP-66JB-T	635 x 175 x 75mm
IP 66	20	11250 W	2250 W	6.5	RS CRR020HP-66-T	762 x 175 x 75mm
460 - 480VAC						
	1	1125 W	56 W	500	RS CRH001HP	165 x 30 x 60mm
IP 54	1	1125 W	150 W	500	RS CRMH001HP-54	167 x 30 x 60mm
IP 66	1	1125 W	600 W	500	RS CRMH001HP-66JB-T	285 x 174 x 75mm
	2	2250 W	112 W	250	RS CRH002HP	265 x 30 x 60mm
IP 54	2	2250 W	168 W	250	RS CRMH02HP-54	267 x 30 x 60mm
IP 66	2	2250 W	600 W	250	RS CRMH02HP-66JB-T	285 x 175 x 75mm
IP 54	5	5625 W	800 W	100	RS CRMH005HP-54	337 x 45 x 120mm
IP 66	5	5625 W	600 W	100	RS CRMH005HP-66JB-T	285 x 174 x 75mm
IP 66	10	11250 W	1200 W	50	RS CRMH010HP-66JB-T	635 x 175 x 75mm
IP 66	20	11250 W	2250 W	25	RS CRRH020HP-66-T	762 x 175 x 75mm





Overtoltage Solutions

M3775R Series

While Bonitron has been the industry leader for Braking Transistors for years, what better way to compliment that than by offering quality resistors too! Bonitron has a vast standard offering of Braking Resistors and welcomes custom requests as well.

M3775R Braking Resistors are used with Bonitron Braking Transistors to allow full power braking and eliminate overvoltage faults. This permits controlled braking and dramatically shortens motor stopping, time. If overvoltage occurs, Bonitron Transistors or the drive's internal brake, shunts excess energy through a Bonitron M3775R Braking Resistor to prevent overvoltage faults.

UL listing option can be quoted for M3775R.



Convection Cooled



A - 10% Duty
B - 50% Duty
C - 100% Duty

L - 230 - 240VAC
E - 380 - 415VAC
H - 460 - 480VAC
C - 575 - 600VAC
Y - 690VAC

VFA - Vertical Fan Exhaust
HFA - Horizontal Fan Exhaust

Model Number Breakdown

Base Model Number
Internal Note
System AC Voltage
Peak Horsepower
Duty Cycle
Enclosure Type (Omit if not 3R)
Forced Air (Omit if convection)

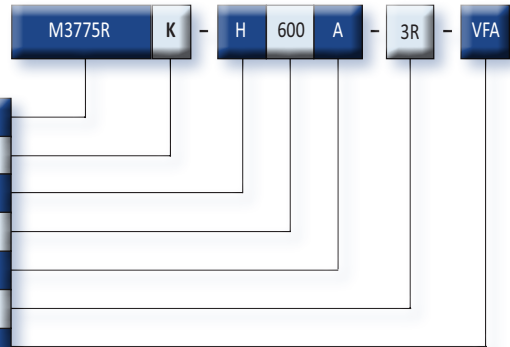

Horizontal Forced Air (HFA)



Vertical Forced Air (VFA)

Product Highlights

- Standard Mill Galvanized Steel Enclosure
 - 306, 316, etc. Stainless Steel Options
- NEMA-3R Options
- Thermal switch comes standard

Voltages.....230 - 690VAC
Current Rating.....Up to 1600Amps
Duty Cycle.....10 % Overhauling/ 20% Braking
 50% Overhauling
 100% Overhauling



Braking Resistors

M3775RPF



Overvoltage Solutions

While Bonitron has been the industry leader for Braking Transistors for years, what better way to compliment that than by offering quality resistors too! Bonitron now offers Modular Braking Resistors which can be configured for ratings from 100 to 1200 horsepower. The M3775RPF is a standard stock item, meaning shorter lead times and faster completion of your process installation.

M3775RPF Braking Resistors are used with Bonitron Braking Transistors to allow full power braking and eliminate overvoltage faults. This permits controlled braking and dramatically shortens motor stopping, time. If overvoltage occurs, Bonitron Transistors or the drive's internal brake, shunts excess energy through a Bonitron M3775RPF Braking Resistor to prevent overvoltage faults.



M3775RPF Series

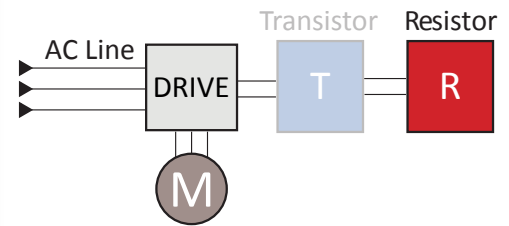

Product Highlights

- Standard Powder Coat ANSI Grey Enclosure
 - 304, 316 Stainless Steel Options
 - Weather-Proof Blow Open Top
 - NEMA-3R Standard
 - Thermal switch comes standard
- Voltages.....460 - 600VAC**
Power Rating.....Up to 1200 HP
Duty Cycle.....100% Overhauling

Several of our Industry Brochures feature our Bonitron Braking Resistors. Learn more at Bonitron.com/industries.html



Marine



Centrifuge



Logging & Sawmill



Crane & Hoist



Oil & Gas





Overvoltage Solutions

Model Number Breakdown

Base Model Number
Internal Note
System AC Voltage
Peak Horsepower
Duty Cycle
Enclosure Type
Forced Air

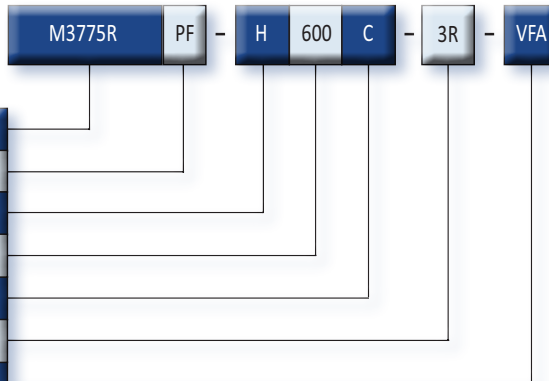

System AC Voltage

- H - 460-480VAC
- C - 575-600VAC

Duty Cycle

- C - 100% Duty

Forced Air

- VFA - Vertical Fan Exhaust

Stainless Steel Options

- Contact Bonitron



Model Number Selection

	Cont. HP	Peak HP	Peak Amps	Ohms	Model Number	Dimensions (H x W x D)
460 - 480 VAC 750VDC						
	100 HP	100 HP	100 A	7.54 Ω	M3775RPF-H100C-3R-VFA	76.0" x 49.0" x 39.5"
	200 HP	200 HP	200 A	3.77 Ω	M3775RPF-H200C-3R-VFA	76.0" x 49.0" x 39.5"
	300 HP	300 HP	300 A	2.51 Ω	M3775RPF-H300C-3R-VFA	76.0" x 49.0" x 39.5"
	400 HP	400 HP	400 A	1.88 Ω	M3775RPF-H400C-3R-VFA	76.0" x 49.0" x 39.5"
	500 HP	500 HP	500 A	1.51 Ω	M3775RPF-H500C-3R-VFA	88.0" x 49.0" x 39.5"
	600 HP	600 HP	600 A	1.26 Ω	M3775RPF-H600C-3R-VFA	88.0" x 49.0" x 39.5"
	700 HP	700 HP	700 A	1.08 Ω	M3775RPF-H700C-3R-VFA	88.0" x 49.0" x 39.5"
	800 HP	800 HP	800 A	0.94 Ω	M3775RPF-H800C-3R-VFA	88.0" x 49.0" x 39.5"
	900 HP	900 HP	900 A	0.84 Ω	M3775RPF-H900C-3R-VFA	100.0" x 49.0" x 39.5"
	1000 HP	1000 HP	1000 A	0.75 Ω	M3775RPF-H1000C-3R-VFA	100.0" x 49.0" x 39.5"
	1200 HP	1200 HP	1200 A	0.63 Ω	M3775RPF-H1200C-3R-VFA	100.0" x 49.0" x 39.5"
575 - 600 VAC 940VDC						
	100 HP	150 HP	125 A	7.54 Ω	M3775RPF-C100C-3R-VFA	76.0" x 49.0" x 39.5"
	200 HP	310 HP	250 A	3.77 Ω	M3775RPF-C200C-3R-VFA	76.0" x 49.0" x 39.5"
	300 HP	460 HP	375 A	2.51 Ω	M3775RPF-C300C-3R-VFA	76.0" x 49.0" x 39.5"
	400 HP	620 HP	500 A	1.88 Ω	M3775RPF-C400C-3R-VFA	76.0" x 49.0" x 39.5"
	500 HP	780 HP	625 A	1.51 Ω	M3775RPF-C500C-3R-VFA	88.0" x 49.0" x 39.5"
	600 HP	930 HP	750 A	1.26 Ω	M3775RPF-C600C-3R-VFA	88.0" x 49.0" x 39.5"
	700 HP	1090 HP	870 A	1.08 Ω	M3775RPF-C700C-3R-VFA	88.0" x 49.0" x 39.5"
	800 HP	1250 HP	1000 A	0.94 Ω	M3775RPF-C800C-3R-VFA	88.0" x 49.0" x 39.5"
	900 HP	1400 HP	1120 A	0.84 Ω	M3775RPF-C900C-3R-VFA	100.0" x 49.0" x 39.5"
	1000 HP	1570 HP	1250 A	0.75 Ω	M3775RPF-C1000C-3R-VFA	100.0" x 49.0" x 39.5"
	1200 HP	1870 HP	1500 A	0.63 Ω	M3775RPF-C1200C-3R-VFA	100.0" x 49.0" x 39.5"



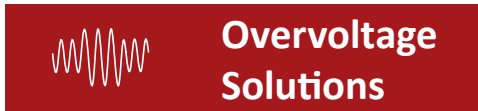

M3575R
Series

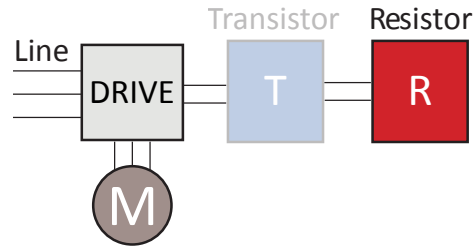

Product Highlights

- UL & CUL Listed
- Wall or cabinet mountable
- Installable with new application or as retrofit
- Rapid installation increases up time
- Terminal access covers are standard

230 - 240VAC

230 - 240VAC 375VDC Setpoint						
Braking HP	Model Number	Power		Resistance	Dimensions (H x W x D)	
		Peak	Cont.			
6% Duty						
1 HP	M3575R-L1M0	746 W	46 W	190 Ω	12.75" x 4.00" x 9.50"	
2 HP	M3575R-L2M0	1492 W	91 W	95 Ω	12.75" x 4.00" x 9.50"	
3 HP	M3575R-L3M0	2238 W	137 W	63 Ω	12.75" x 4.00" x 9.50"	
4 HP	M3575R-L4M0	2984 W	182 W	48 Ω	12.75" x 7.00" x 9.50"	
5 HP	M3575R-L5B0	3730 W	243 W	38 Ω	17.75" x 4.00" x 9.50"	
6 HP	M3575R-L6M0	4476 W	274 W	32 Ω	12.75" x 7.00" x 9.50"	
8 HP	M3575R-L8B0	5968 W	365 W	25 Ω	17.75" x 4.00" x 9.50"	
9 HP	M3575R-L9M0	6714 W	410 W	21 Ω	12.75" x 10.00" x 9.50"	
11 HP	M3575R-L11B0	8206 W	486 W	19 Ω	17.75" x 7.00" x 9.50"	
16 HP	M3575R-L16B0	11936 W	730 W	13 Ω	17.75" x 7.00" x 9.50"	
24 HP	M3575R-L24B0	17904 W	1094 W	8 Ω	17.75" x 10.00" x 9.50"	
20% Duty						
1 HP	M3575R-L1MF	746 W	152 W	190 Ω	12.75" x 4.00" x 9.50"	
2 HP	M3575R-L2MF	1492 W	304 W	95 Ω	12.75" x 4.00" x 9.50"	
3 HP	M3575R-L3MF	2238 W	456 W	63 Ω	12.75" x 4.00" x 9.50"	
4 HP	M3575R-L4MF	2984 W	608 W	48 Ω	12.75" x 7.00" x 9.50"	
5 HP	M3575R-L5BF	3730 W	811 W	38 Ω	17.75" x 4.00" x 9.50"	
6 HP	M3575R-L6MF	4476 W	912 W	32 Ω	12.75" x 7.00" x 9.50"	
8 HP	M3575R-L8BF	5968 W	1216 W	25 Ω	17.75" x 4.00" x 9.50"	
9 HP	M3575R-L9MF	6714 W	1368 W	21 Ω	12.75" x 10.00" x 9.50"	
11 HP	M3575R-L11BF	8206 W	1621 W	19 Ω	17.75" x 7.00" x 9.50"	
16 HP	M3575R-L16BF	11936 W	2432 W	13 Ω	17.75" x 7.00" x 9.50"	
24 HP	M3575R-L24BF	17904 W	3648 W	8 Ω	17.75" x 10.00" x 9.50"	





Overvoltage Solutions



Bonitron M3575R Braking Resistors help protect drives from overvoltage faults by dissipating excess regenerative energy as heat. M3575R Braking Resistors are commonly used in applications where infrequent, low duty cycle, or low horsepower regeneration occurs.

M3575R Braking Resistors are easily applied as resistive loads for use with a drive's internal or external braking transistor. Sizes up to 33 horsepower in a single unit are available and may be paralleled for higher requirements. Units have been designed and tested to ensure that cabinet temperatures are less than 85° Celsius.

For resistors rated up to the megawatts see the Bonitron M3775R Resistive Load Bank Series. Custom resistors are also available.

460 - 480VAC

	460 - 480VAC 750VDC Setpoint					
	Drive HP	Model Number	Power		Resistance	Dimensions (H x W x D)
			Peak	Cont.		
6% Duty						
	1 HP	M3575R-H1M0	746 W	45 W	780 Ω	12.75" x 4.00" x 9.50"
	2 HP	M3575R-H2M0	1492 W	90 W	390 Ω	12.75" x 4.00" x 9.50"
	3 HP	M3575R-H3M0	2238 W	135 W	260 Ω	12.75" x 4.00" x 9.50"
	4 HP	M3575R-H4M0	2984 W	180 W	195 Ω	12.75" x 7.00" x 9.50"
	5 HP	M3575R-H5B0	3730 W	225 W	150 Ω	17.75" x 4.00" x 9.50"
	6 HP	M3575R-H6M0	4476 W	270 W	130 Ω	12.75" x 7.00" x 9.50"
	8 HP	M3575R-H8B0	5968 W	360 W	90 Ω	17.75" x 4.00" x 9.50"
	9 HP	M3575R-H9M0	6714 W	405 W	87 Ω	12.75" x 10.00" x 9.50"
	11 HP	M3575R-H11B0	8206 W	495 W	60 Ω	17.75" x 7.00" x 9.50"
	16 HP	M3575R-H16B0	11936 W	720 W	45 Ω	17.75" x 7.00" x 9.50"
	24 HP	M3575R-H24B0	17904 W	1080 W	30 Ω	17.75" x 10.00" x 9.50"
20% Duty						
	1 HP	M3575R-H1MF	746 W	150 W	780 Ω	12.75" x 4.00" x 9.50"
	2 HP	M3575R-H2MF	1492 W	300 W	390 Ω	12.75" x 4.00" x 9.50"
	3 HP	M3575R-H3MF	2238 W	450 W	260 Ω	12.75" x 4.00" x 9.50"
	4 HP	M3575R-H4MF	2984 W	600 W	195 Ω	12.75" x 7.00" x 9.50"
	5 HP	M3575R-H5BF	3730 W	750 W	150 Ω	17.75" x 4.00" x 9.50"
	6 HP	M3575R-H6MF	4476 W	900 W	130 Ω	12.75" x 7.00" x 9.50"
	8 HP	M3575R-H8BF	5968 W	1200 W	90 Ω	17.75" x 4.00" x 9.50"
	9 HP	M3575R-H9MF	6714 W	1350 W	87 Ω	12.75" x 10.00" x 9.50"
	11 HP	M3575R-H11BF	8206 W	1650 W	60 Ω	17.75" x 7.00" x 9.50"
	16 HP	M3575R-H16BF	11936 W	2400 W	45 Ω	17.75" x 7.00" x 9.50"
	24 HP	M3575R-H24BF	17904 W	3600 W	30 Ω	17.75" x 10.00" x 9.50"
	28 HP	M3575R-H27BF	20888 W	1800 W	28.2 Ω	17.75" x 10.00" x 9.50"
	33 HP	M3575R-H33BF	24618 W	3600 W	22.5 Ω	17.75" x 10.00" x 11.50"





M3452 Complete Series

Combination Braking Modules are used with AC drives to allow full power braking and eliminate overvoltage faults. This permits controlled braking and dramatically shortens motor stopping time. Bonitron Combination Braking Modules work with variable frequency drives to monitor the DC bus. If overvoltage occurs, the internal transistor shunts the excess energy through an internal braking resistor to prevent overvoltage faults.

Combination Braking Modules include a braking transistor and resistor in one convenient enclosure. This makes installation much quicker, as it eliminates the need to wire separate components.

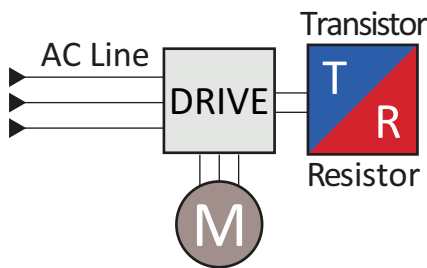

Product Highlights

- 230 - 600 VAC | Up to 43HP
- NEMA-1 enclosure
- Transistor and resistor in one package
- Requires less installation wiring
- Reduced footprint
- Simple connection to the DC bus

	Peak HP	Model Number	Cont. Watts	Resistance	Duty Cycle		Dimensions (H x W x D)	UL and CUL Listing
					Braking	Overhauling		
230-240 VAC 375VDC Setpoint								
	6.3 HP	M3452-L2B-R030	400 W	30 Ω	20%	10%	18.25" x 9.50" x 8.50"	UL and CUL
	6.3 HP	M3452-L3B-R030	600 W	30 Ω	20%	10%	18.25" x 9.50" x 8.50"	UL and CUL
	9.4 HP	M3452-L3B-R020	600 W	20 Ω	20%	10%	18.25" x 9.50" x 8.50"	UL and CUL
	12.6 HP	M3452-L9C-R015	1800 W	15 Ω	40%	20%	18.25" x 11.50" x 10.50"	UL and CUL
	18.9 HP	M3452-L6B-R010	1200 W	10 Ω	20%	10%	18.25" x 9.50" x 8.50"	UL and CUL
	28.1 HP	M3452-L9C-R007	1800 W	6.7 Ω	20%	10%	18.25" x 11.50" x 10.50"	UL and CUL
	42.8 HP	M3452-L8C-R004	1600 W	4.4 Ω	10%	5%	18.25" x 11.50" x 10.50"	UL and CUL
460-480 VAC 750VDC Setpoint								
	6.3 HP	M3452-H2B-R120	400 W	120 Ω	20%	10%	18.25" x 9.50" x 8.50"	UL and CUL
	7.0 HP	M3452-H9C-R108	1800 W	108 Ω	60%	30%	18.25" x 11.50" x 10.50"	UL and CUL
	10.1 HP	M3452-H3B-R075	600 W	75 Ω	20%	10%	18.25" x 9.50" x 8.50"	UL and CUL
	15.1 HP	M3452-H9C-R050	1800 W	50 Ω	30%	15%	18.25" x 11.50" x 10.50"	UL and CUL
	20.1 HP	M3452-H6B-R038	1200 W	37.5 Ω	20%	10%	18.25" x 9.50" x 8.50"	UL and CUL
	30.2 HP	M3452-H9C-R025	1800 W	25 Ω	20%	10%	18.25" x 11.50" x 10.50"	UL and CUL
	43.1 HP	M3452-H8C-R018	1600 W	17.5 Ω	10%	5%	18.25" x 11.50" x 10.50"	UL and CUL
575 - 600 VAC 940VDC Setpoint								
	9.9 HP	M3452-C2B-R120	400 W	120 Ω	10%	5%	18.25" x 9.50" x 8.50"	UL and CUL
	11.0 HP	M3452-C9C-R108	1800 W	108 Ω	60%	30%	18.25" x 11.50" x 10.50"	UL and CUL
	11.3 HP	M3452-C3B-R105	600 W	105 Ω	15%	8%	18.25" x 9.50" x 8.50"	UL and CUL
	22.6 HP	M3452-C6B-R053	1200 W	52.5 Ω	20%	10%	18.25" x 9.50" x 8.50"	UL and CUL
	23.7 HP	M3452-C9C-R050	1800 W	50 Ω	20%	10%	18.25" x 11.50" x 10.50"	UL and CUL
	33.8 HP	M3452-C9C-R035	1800 W	35 Ω	20%	10%	18.25" x 11.50" x 10.50"	UL and CUL



The M3500DB Series enhances system performance and safety by providing resistive braking control for emergency stop applications if regenerative braking does not perform.

The M3500DB series provides e-stop braking for servo motion systems and conforms to EN-954 category II or category IV safety requirements. As the secondary brake, the M3500DB stops the motor in case of motion controller or power failure. It also isolates the motor from its power source once it is stopped to increase safety.



M3500DB Series

	Model Number		Contact Type	Resistance	Dimensions (H x W x D)
	EN-954 Category II	EN-954 Category IV			
32A Continuous Motor Current					
	M3500DB-H01A-32	M3500DB4-H01A-32	Normally Closed	1Ω	15.95" x 2.92" x 10.35"
	M3500DB-H01B-32	M3500DB4-H01B-32	Normally Open		
	M3500DB-H03A-32	M3500DB4-H03A-32	Normally Closed	3Ω	15.95" x 2.92" x 10.35"
	M3500DB-H03B-32	M3500DB4-H03B-32	Normally Open		
	M3500DB-H06A-32	M3500DB4-H06A-32	Normally Closed	6Ω	15.95" x 2.92" x 10.35"
	M3500DB-H06B-32	M3500DB4-H06B-32	Normally Open		
	M3500DB-H16A-32	M3500DB4-H16A-32	Normally Closed	16Ω	15.95" x 2.92" x 10.35"
	M3500DB-H16B-32	M3500DB4-H16B-32	Normally Open		
	M3500DB-H36A-32	M3500DB4-H36A-32	Normally Closed	36Ω	15.95" x 2.92" x 10.35"
	M3500DB-H36B-32	M3500DB4-H36B-32	Normally Open		
	M3500DB-H01A-32X	M3500DB4-H01A-32X	Normally Closed	1Ω	15.95" x 2.92" x 10.35"
	M3500DB-H01B-32X	M3500DB4-H01B-32X	Normally Open		
	M3500DB-H03A-32X	M3500DB4-H03A-32X	Normally Closed	3Ω	15.95" x 2.92" x 10.35"
	M3500DB-H03B-32X	M3500DB4-H03B-32X	Normally Open		
	M3500DB-H06A-32X	M3500DB4-H06A-32X	Normally Closed	6Ω	15.95" x 2.92" x 10.35"
	M3500DB-H06B-32X	M3500DB4-H06B-32X	Normally Open		
	M3500DB-H16A-32X	M3500DB4-H16A-32X	Normally Closed	16Ω	15.95" x 2.92" x 10.35"
	M3500DB-H16B-32X	M3500DB4-H16B-32X	Normally Open		
	M3500DB-H36A-32X	M3500DB4-H36A-32X	Normally Closed	36Ω	15.95" x 2.92" x 10.35"
	M3500DB-H36B-32X	M3500DB4-H36B-32X	Normally Open		
43A Continuous Motor Current					
	M3500DB-H01A-43	M3500DB4-H01A-43	Normally Closed	1Ω	15.95" x 2.92" x 10.35"
	M3500DB-H01B-43	M3500DB4-H01B-43	Normally Open		
	M3500DB-H03A-43	M3500DB4-H03A-43	Normally Closed	3Ω	15.95" x 2.92" x 10.35"
	M3500DB-H03B-43	M3500DB4-H03B-43	Normally Open		
65A Continuous Motor Current					
	M3500DB-H0.5A-65		Normally Closed	0.5Ω	15.95" x 7.56" x 10.52"
	M3500DB-H1.5A-65	N/A	Normally Closed	1.5Ω	15.95" x 7.56" x 10.52"
	M3500DB-H03A-65		Normally Closed	3Ω	15.95" x 7.56" x 10.52"
150A Continuous Motor Current					
		M3500DB4-H025A-150	Normally Closed	0.25Ω	20.00" x 10.00" x 10.25"
	N/A	M3500DB4-H0.75A-150	Normally Closed	0.75Ω	20.00" x 10.00" x 10.25"
		M3500DB4-H1.5A-150	Normally Closed	1.5Ω	20.00" x 10.00" x 10.25"



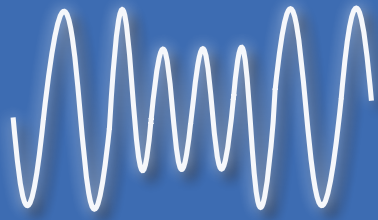

Undervoltage Solutions

UPD Ride-Thru Systems

- Sag Systems
- Capacitor Systems
- Battery Systems

UPD Ride-Thru Lite Voltage Regulators

- M3460R
- M3460B
- M3534

Chargers

- M3528

Energy Storage

- M3528B

Dischargers

- KIT3628T





Understanding Ride-Thru Applications

What is Ride-Thru?

The Bonitron Sag UPD Ride-Thru systems provide protection from 60% 3-phase AC line voltage sags or the loss of one phase for up to 2 seconds without loss of motor speed or torque.

The Bonitron Outage UPD Ride-Thru systems provide protection from AC line voltage sags or the loss of all three phases for up to 15 minutes.

Bonitron UPD Ride-Thru systems are designed for AC drive systems that use a fixed DC bus, such as AC variable speed drives (VSD). Unfortunately, VSDs are quite susceptible to fluctuations in incoming power. Bonitron UPD Ride-Thru systems provide the security of “riding through” these events.

DC Bus with Ride-Thru Protection

AC Line Voltage

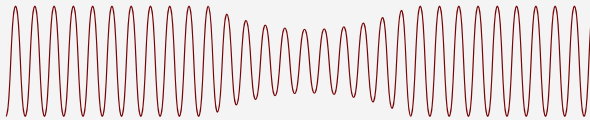

DC Bus Voltage

Unprotected DC Bus

AC Line Voltage

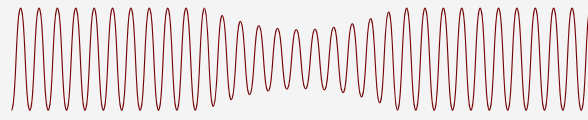

DC Bus Voltage

Bonitron UPD Ride-Thru System Selection

		Ride-Thru Duration	Voltage Regulator	Charger	Energy Storage	Discharger	Interactive Display
SAG	S3534SR	Sag 2 sec	●	N/A	N/A	N/A	●
	S3460SR	Sag 2 sec	●	N/A	N/A	N/A	●
OUTAGE (CAPACITOR)	S3534EC	Outage 0.5 sec	N/A	N/A	Electrolytic	N/A	
	S3534CR	Outage 2 sec	●	●	Electrolytic	●	Optional
	S3534UR	Outage 15 sec	●	●	Ultracapacitor	●	●
	S3460UR	Outage 15 sec	●	●	Ultracapacitor	●	●
OUTAGE (BATTERY)	S3534BR	Outage Up to 60 sec	●	●	Battery	N/A	●
	S3460BR	Outage Up to 15 min	●	●	Battery	N/A	●

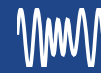

Electricity travels miles to reach the drives and motors that control your process. While outdoor power lines and substations are vulnerable to power outages caused by cars, weather, and even animals, the lines inside your plant are susceptible to power quality events as well.

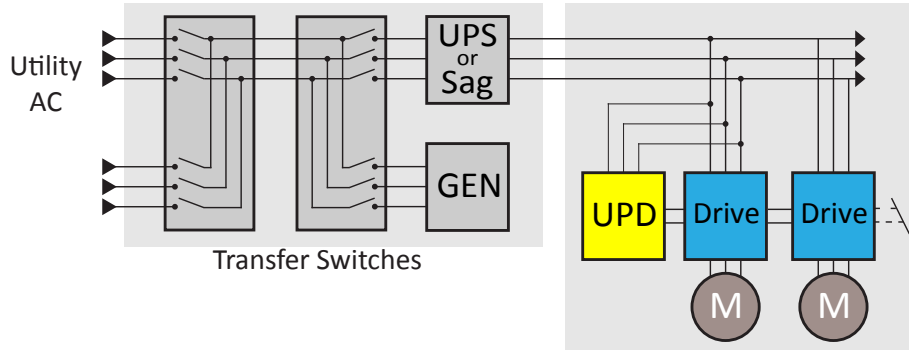

Unlike typical plant wide solutions, Bonitron designed its UPD solutions to connect directly to the DC terminals of one or multiple drives. If drive voltage sags, the Bonitron UPD immediately provides power so motor speed is not affected and the process never sees a disturbance. When properly sized, Bonitron UPD systems provide drives with full-load power until the AC line is restored or generators are online.

Bonitron Battery UPD Systems use battery DC energy to power the DC bus of the drive via DC bus connection terminals on the drive. This eliminates an unnecessary and energy-wasting DC to AC conversion.

Bonitron UPD Advantages

- **Parallel Connection**
 - High reliability
 - Seamless power source transfer
- **Increased efficiency**
 - Ultra-low standby power
 - Sized to drive system for reduced cost
 - Power supplied to DC bus for minimal conversions

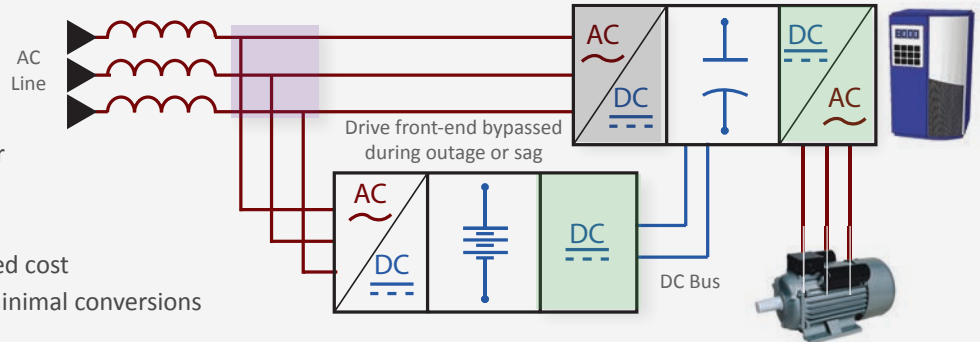

Competitors' double conversion UPS systems convert DC voltage that is stored in batteries or capacitors back to AC voltage in order to power the drive, which in turn converts it back to DC. Variable frequency drives are not recommended for use with UPS Systems, as the drive input reactance interacts negatively with UPS inverters.

In-line UPS Disadvantages

- **Series Connection**
 - Decreased reliability
- **Decreased efficiency**
 - Unnecessary conversions
 - Converts energy storage back to AC

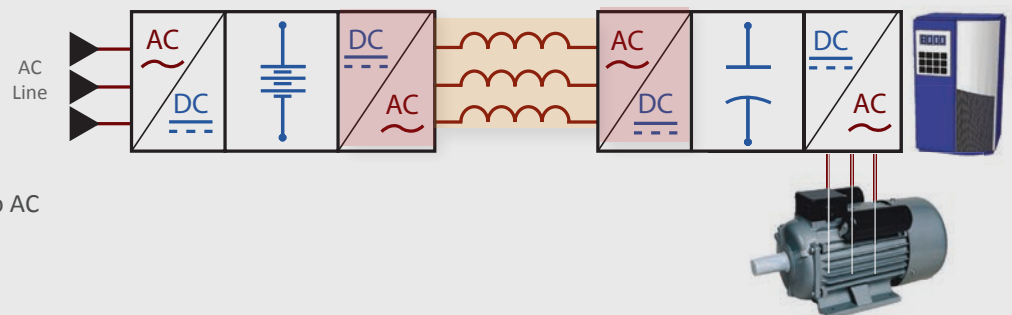



Undervoltage Solutions

Bonitron UPD Systems (Uninterruptible Power for Drives) are the cost effective way to ensure your critical process never sees power disturbances from voltage sags or **outages lasting up to 4 minutes**. Bonitron UPD Systems include a voltage regulator that monitors the drive's DC bus voltage. If drive voltage sags or disappears, the system becomes active immediately and provides power to the DC bus so that the process is not affected.



Product Highlights

Sag UPD Ride-Thru Systems

- No energy storage required
- Full load power for up to 2 seconds
 - 60% 3-phase sags
 - Single phase sag to 0V

Capacitor UPD Ride-Thru Systems

- Electrolytic or ultracapacitor energy storage
- Full load power for up to 15 seconds
 - 100%, 3-phase outages

Battery UPD Ride-Thru Systems

- Battery energy storage
- Full-load power for up to 15 minutes
 - 100%, 3-phase outages

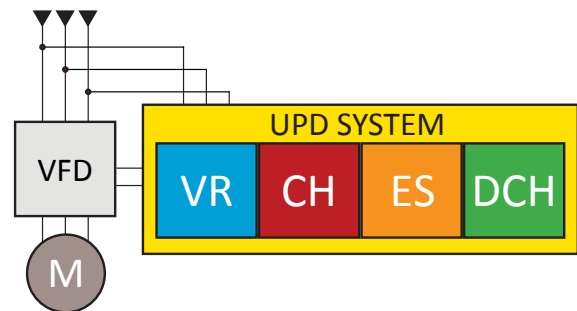

Uninterruptible Power for Drives (UPD)

Sized to drive system process

- Typically much lower cost than plant-wide UPS
- Support single or multiple drives with one UPD System

Parallel Connection

- High reliability
- Test system with no effect on process
- Very low standby power

Seamless power transfer from utility, to Bonitron, to generator or restored utility

- 208 – 575VAC systems



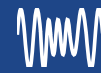

Some processes may not require uninterruptible power, but just enough to shut down safely or reset the equipment to a default position. For these applications, a Bonitron UPD can be undersized to 10-20% of the motor HP, greatly reducing the cost.

Bonitron UPD Systems (Uninterruptible Power for Drives) are the cost effective way to ensure your process safely shuts down or resets to the default position. UPD Systems include a voltage regulator that monitors the drive's DC bus voltage. If drive voltage disappears, the system can turn on immediately or can be manually enabled to provide power to the DC bus so that the process is shutdown safely.

Uninterruptible Power for Drives (UPD)

Parallel Connection

- High Reliability
- Seamless power transfer

Increased Efficiency

- Ultra low standby power
- Sized to 10-20% of drive
- Few AC/DC conversions

Product Highlights

- Cost effective emergency power system for processes that do not require uninterruptible power
- Sized to 10-20% of the drive HP
- Provides low speed, safe shutdown or reset to default position

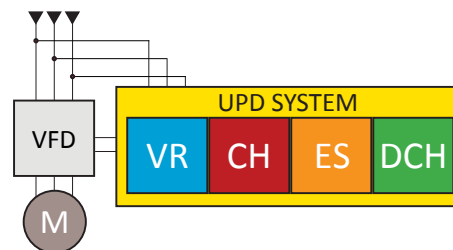

Extruders

Purge system before solidification

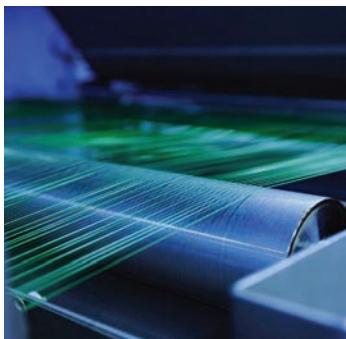

Cranes & Hoists

Lower load to a safe position



Ovens

Move system before product or conveyor damaged by heat



Elevators

Move to nearest floor





Undervoltage Solutions

Bonitron Undervoltage Ride-Thru Solutions, also known as Uninterruptible Power for Drives, include a DC Voltage Regulator (M3460B or M3460R) that monitors the drive. If the drive voltage sags or disappears, the Voltage Regulator becomes active and provides power to the DC bus. This allows critical processes to never see the disturbance and can continue operating at full power. Thanks to Bonitron's parallel connection, very low standby power and long product life can be expected.



Digital Display

The KIT 3660DD5 is an interactive digital display for the 3460 Series that monitors and stores history of power quality issues, including status, voltage, and current.

M3460R Series



System Power	Peak Current	Max. On-time at Rating	Model Number	Dimensions (H x W x D)
230 - 240 VAC				
25 kW	85 A	2 Seconds	M3460R-L025-R10-F	28.00" x 16.00" x 14.00"
38 kW	127 A	2 Seconds	M3460R-L038-R10-F	28.00" x 16.00" x 14.00"
50 kW	170 A	2 Seconds	M3460R-L050-R9-F	34.00" x 16.00" x 14.00"
75 kW	255 A	2 Seconds	M3460R-L075-R11-F	44.00" x 16.00" x 14.00"
100 kW	340 A	2 Seconds	M3460R-L100-R11-F	44.00" x 16.00" x 14.00"
125 kW	425 A	2 Seconds	M3460R-L125-R11-F	44.00" x 16.00" x 14.00"
380 - 415 VAC				
43 kW	85 A	2 Seconds	M3460R-E043-R10-F	28.00" x 16.00" x 14.00"
65 kW	127 A	2 Seconds	M3460R-E065-R10-F	28.00" x 16.00" x 14.00"
87 kW	170 A	2 Seconds	M3460R-E087-R9-F	34.00" x 16.00" x 14.00"
130 kW	255 A	2 Seconds	M3460R-E130-R11-F	44.00" x 16.00" x 14.00"
175 kW	340 A	2 Seconds	M3460R-E175-R11-F	44.00" x 16.00" x 14.00"
215 kW	425 A	2 Seconds	M3460R-E215-R11-F	44.00" x 16.00" x 14.00"
433 - 480 VAC				
50 kW	85 A	2 Seconds	M3460R-H050-R10-F	28.00" x 16.00" x 14.00"
75 kW	127 A	2 Seconds	M3460R-H075-R10-F	28.00" x 16.00" x 14.00"
100 kW	170 A	2 Seconds	M3460R-H100-R9-F	34.00" x 16.00" x 14.00"
150 kW	255 A	2 Seconds	M3460R-H150-R11-F	44.00" x 16.00" x 14.00"
200 kW	340 A	2 Seconds	M3460R-H200-R11-F	44.00" x 16.00" x 14.00"
250 kW	425 A	2 Seconds	M3460R-H250-R11-F	44.00" x 16.00" x 14.00"
575 - 600 VAC				
60 kW	85 A	2 Seconds	M3460R-C060-R10	28.00" x 16.00" x 14.00"
90 kW	127 A	2 Seconds	M3460R-C090-R10	28.00" x 16.00" x 14.00"
125 kW	170 A	2 Seconds	M3460R-C125-R9	34.00" x 16.00" x 14.00"
185 kW	255 A	2 Seconds	M3460R-C185-R11	44.00" x 16.00" x 14.00"
245 kW	340 A	2 Seconds	M3460R-C245-R11	44.00" x 16.00" x 14.00"
305 kW	425 A	2 Seconds	M3460R-C305-R11	44.00" x 16.00" x 14.00"



M3460B



M3460B Series



M3460R vs. M3460B

M3460R

- Protect drives and processes from 2-second power sags
- Used with energy storage to protect from outages lasting up to 15 seconds
 - electrolytic
 - ultracapacitors

M3460B

- Battery Voltage Regulators are used with energy storage, such as batteries, to protect drives and processes from outages lasting up to 15 minutes to allow time for generator start-up
- With seamless power transfer, the M3534B or M3460B allow seamless power transfer from the grid to generator.

System Power	Peak Current	Max. On-time at Rating	Model Number	Dimensions (H x W x D)
230 - 240 VAC				
25 kW	85 A	4 Minutes	M3460B-L025-240-R10	28.00" x 16.00" x 14.00"
38 kW	127 A	4 Minutes	M3460B-L038-240-R9	34.00" x 16.00" x 14.00"
50 kW	170 A	4 Minutes	M3460B-L050-240-R9	34.00" x 16.00" x 14.00"
75 kW	255 A	4 Minutes	M3460B-L075-240-R2	52.00" x 24.00" x 14.00"
100 kW	340 A	4 Minutes	M3460B-L100-240-R2	52.00" x 24.00" x 14.00"
380 - 415 VAC				
43 kW	85 A	4 Minutes	M3460B-E043-240-R10	28.00" x 16.00" x 14.00"
65 kW	127 A	4 Minutes	M3460B-E065-240-R9	34.00" x 16.00" x 14.00"
87 kW	170 A	4 Minutes	M3460B-E087-240-R9	34.00" x 16.00" x 14.00"
130 kW	255 A	4 Minutes	M3460B-E130-240-R2	52.00" x 24.00" x 14.00"
175 kW	340 A	4 Minutes	M3460B-E175-240-R2	52.00" x 24.00" x 14.00"
433 - 480 VAC				
50 kW	85 A	4 Minutes	M3460B-H050-240-R10	28.00" x 16.00" x 14.00"
75 kW	127 A	4 Minutes	M3460B-H075-240-R9	34.00" x 16.00" x 14.00"
100 kW	170 A	4 Minutes	M3460B-H100-240-R9	34.00" x 16.00" x 14.00"
150 kW	255 A	4 Minutes	M3460B-H150-240-R2	52.00" x 24.00" x 14.00"
200 kW	340 A	4 Minutes	M3460B-H200-240-R2	52.00" x 24.00" x 14.00"
575 - 600 VAC				
60 kW	85 A	4 Minutes	M3460B-C060-240-R10	28.00" x 16.00" x 14.00"
90 kW	127 A	4 Minutes	M3460B-C090-240-R9	28.00" x 16.00" x 14.00"
125 kW	170 A	4 Minutes	M3460B-C125-240-R9	34.00" x 16.00" x 14.00"
185 kW	255 A	4 Minutes	M3460B-C185-240-R2	44.00" x 16.00" x 14.00"
245 kW	340 A	4 Minutes	M3460B-C245-240-R2	44.00" x 16.00" x 14.00"



Undervoltage Solutions

Bonitron Undervoltage Ride-Thru Solutions, also known as Uninterruptible Power for Drives, include a DC Voltage Regulator (M3534) that monitors the drive. If the drive voltage sags or disappears, the Voltage Regulator becomes active and provides power to the DC bus. This allows critical processes to never see the disturbance and can continue operating at full power. Thanks to Bonitron's parallel connection, very low standby power and long product life can be expected.

The **M3534R** is a Voltage Regulator that protects drives and processes from 2-second power sags. It can also be used with energy storage, such as electrolytic or ultracapacitors, to protect from outages lasting up to 2 seconds.

The **M3534B** is a Battery Voltage Regulator that is used with energy storage, such as batteries, to protect drives and processes from outages lasting up to 60 seconds to allow time for generator startup. With seamless power transfer, the M3534B (with appropriate components - M3528 Charger and Batteries) allows seamless power transfer from the grid, to Bonitron, to generator.



M3534
Series

Specifications

Input AC Line.....208 - 480 VAC
Output DC Bus.....265 - 650 VDC
Bus Current Rating.....20 – 85 ADC
Power Rating.....6 - 50 kW
Run Time.....2 seconds – 60 seconds

Uninterruptible Power for Drives (UPD)

Parallel Connection

- High Reliability
- Seamless power transfer

Increased Efficiency

- Ultra low standby power
- Sized to drive systems
- Few AC/DC conversions

	Current	Power	Max. On-Time (at rating)	Model Number	Dimensions (H x W x D)
230 - 240 VAC					
	20 A	6 kW	2 Seconds	M3534R-L006-A5-I3	18.60" x 5.10" x 9.40"
	40 A	12 kW	2 Seconds	M3534R-L012-K7-I3	20.00" x 7.40" x 10.30"
			60 Seconds	M3534B-L012-K9-I3	20.00" x 9.10" x 10.30"
	85 A	25 kW	2 Seconds	M3534R-L025-A9-I3	22.10" x 8.70" x 10.30"
380 - 415 VAC					
	20 A	10 kW	2 Seconds	M3534R-E010-A5-I3	18.60" x 5.10" x 9.40"
	40 A	20 kW	2 Seconds	M3534R-E020-K7-I3	20.00" x 7.40" x 10.30"
			60 Seconds	M3534B-E020-K9-I3	20.00" x 9.10" x 10.30"
	85 A	42 kW	2 Seconds	M3534R-E042-A9-I3	22.10" x 8.70" x 10.30"
460 - 480 VAC					
	20 A	12 kW	2 Seconds	M3534R-H012-A5-I3	18.60" x 5.10" x 9.40"
	40 A	24 kW	2 Seconds	M3534R-H024-K7-I3	20.00" x 7.40" x 10.30"
			60 Seconds	M3534B-H024-K9-I3	20.00" x 9.10" x 10.30"
	85 A	50 kW	2 Seconds	M3534R-H050-A9-I3	22.10" x 8.70" x 10.30"



M3528

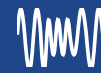

Undervoltage Solutions



M3528 Series

Bonitron M3528 Chargers maintain energy levels in batteries and ultracapacitors.

Some industrial systems require back-up power to protect critical processes from power outages and voltage sags. Energy storage devices such as batteries and capacitors are required for outage protection. A charger is necessary to keep the energy storage reservoirs at the appropriate levels.

Product Highlights

- Maintain energy levels in batteries and ultracapacitors
- Adjustable current limit
- LED indicators
- Isolated status contacts

UL Listed when used with capacitors



Uninterruptible Power for Drives (UPD)

Parallel Connection

- High Reliability
- Seamless power transfer

Increased Efficiency

- Ultra low standby power
- Sized to drive systems
- Few AC/DC conversions

Isolation Transformer required. Contact Bonitron for sizing.

	Charger					
	Max Charge Current	Input Voltage	Model Number	Charge Voltage	Dimensions (H x W x D)	
208 - 230VAC						
	10A	160-253VAC	M3528AC-L010-A6	175-325VDC	18.60" x 6.25" x 11.25"	
	20A	160-253VAC	M3528AC-L020-K8	175-325VDC	20.00" x 8.20" x 11.10"	
380 - 415VAC						
	10A	277-506VAC	M3528AC-E010-A6	325-600VDC	18.60 x 6.25 x 11.25"	
	20A	277-506VAC	M3528AC-E020-K8	325-600VDC	20.00" x 8.20" x 11.10"	
460 - 480VAC						
	10A	277-506VAC	M3528AC-H010-A6	325-600VDC	18.60" x 6.25" x 11.25"	
	20A	277-506VAC	M3528AC-H020-K8	325-600VDC	20.00" x 8.20" x 11.10"	
575 - 600VAC						
	5A	346-600VAC	M3528AC-C005-A6	406-675VDC	18.60" x 6.25" x 11.25"	





Undervoltage Solutions



M3528B Series

The M3528B Battery Energy Storage Modules are designed for simple integration and scalability, and are typically used in conjunction with Bonitron Battery Voltage Regulators and Battery Chargers to provide critical processes with 100% power outage protection or offer "dark start" capabilities. M3528B Battery Modules are offered in 108V and 120V and can be connected in series or parallel to be used with 230 or 460VAC systems.

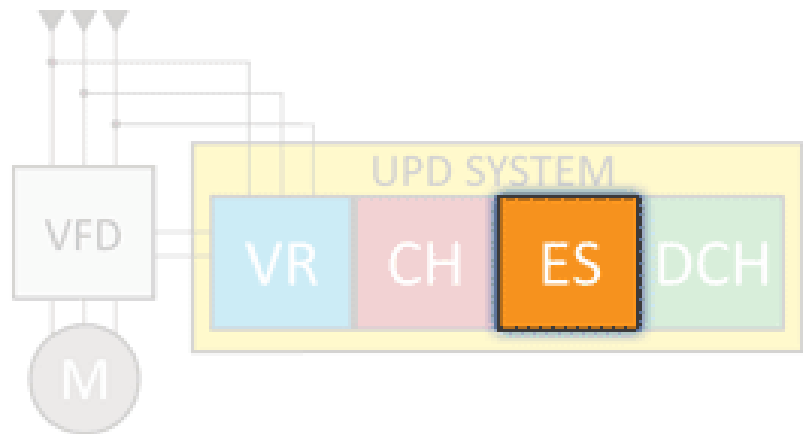

	System Voltage	Model Number	Peak Output Current	Quantity	Enclosure	Dimensions (H x W x D)	
	208 VAC	M3528B-108-040-B5	40 A	2	NEMA-1 with Connector	17.60" x 5.10" x 9.40"	
	230 VAC	M3528B-120-040-B5					
	400 VAC	M3528B-108-040-B5	40 A	4	NEMA-1 with Connector	17.60" x 5.10" x 9.40"	
	460 VAC	M3528B-120-040-B5					



KIT3628

KIT3628 Series



Undervoltage Solutions



Product Highlights

- Discharge energy in electrolytic and ultracapacitors
- Consists of transistor and resistor
- Ability to abort discharge cycle
- Units may be paralleled for faster discharge

	Charge Voltage (VDC)	Capacitance (Farad)	Energy (kJ)	M3628T Transistor	M3628R Resistor
	400 VDC	4.4 F	350 kJ	KIT 3628T-Y200-V2	M3628R-05.0-0350-6T
		9.4 F	750 kJ		M3628R-03.0-0750-6H
	400 VDC	19 F	1500 kJ	KIT 3628T-Y600-V2	M3628R-00.8-1500-6H
		25 F	2000 kJ		M3628R-00.8-2000-6H
		38 F	3000 kJ		M3628R-00.7-3000-10H
		50 F	4000 kJ		M3628R-00.7-4000-14H
	450 VDC	3.5 F	350 kJ	KIT 3628T-Y200-V2	M3628R-05.0-0350-6T
		7.4 F	750 kJ		M3628R-03.0-0750-6H
	450 VDC	15 F	1500 kJ	KIT 3628T-Y600-V2	M3628R-00.8-1500-6H
		20 F	2000 kJ		M3628R-00.8-2000-6H
		30 F	3000 kJ		M3628R-00.8-3000-10H
		40 F	4000 kJ		M3628R-00.8-4000-14H
	500 VDC	2.8 F	350 kJ	KIT 3628T-Y200-V2	M3628R-03.5-0350-6T
		6.0 F	750 kJ		M3628R-03.5-0750-6H
	500 VDC	12 F	1500 kJ	KIT 3628T-Y600-V2	M3628R-01.0-1500-6H
		16 F	2000 kJ		M3628R-01.0-2000-6H
		24 F	3000 kJ		M3628R-09.0-3000-10H
		32 F	4000 kJ		M3628R-09.0-4000-14H
	550 VDC	2.3 F	350 kJ	KIT 3628T-Y200-V2	M3628R-04.0-0350-6T
		4.9 F	750 kJ		M3628R-04.0-0750-6H
	550 VDC	10 F	1500 kJ	KIT 3628T-Y600-V2	M3628R-01.0-1500-6H
		13 F	2000 kJ		M3628R-01.0-2000-6H
		20 F	3000 kJ		M3628R-01.0-3000-10H
		26 F	4000 kJ		M3628R-01.0-4000-14H
	600 VDC	1.9 F	350 kJ	KIT 3628T-Y200-V2	M3628R-04.0-0350-6T
		4.2 F	750 kJ		M3628R-04.0-0750-6H
	600 VDC	8.3 F	1500 kJ	KIT 3628T-Y600-V2	M3628R-01.0-1500-6H
		11 F	2000 kJ		M3628R-01.0-2000-6H
		17 F	3000 kJ		M3628R-01.0-3000-10H
		22 F	4000 kJ		M3628R-01.0-4000-14H

*Contact Bonitron for additional voltages and sizes



www.bonitron.com



615-244-2825

info@bonitron.com





Undervoltage Solutions

KIT 3660DD5



Digital Display

The KIT 3660DD5 is an interactive digital display for the 3460 Series that monitors and stores history of power quality issues, including status, voltage, and current.

	Voltage Regulator			Charger	Model Number
	M3460R Current	M3460B Current	M3534 Current	Use with M3528	
	N/A	N/A	20 A	Yes	KIT 3660DD5-050050C
				No	KIT 3660DD5-050050X
	N/A	N/A	40 A	Yes	KIT 3660DD5-100050C
				No	KIT 3660DD5-100050X
	85 A	85 A	85 A	Yes	KIT 3660DD5-200100C
				No	KIT 3660DD5-200100X
	127 - 170 A	127 - 170 A	N/A	Yes	KIT 3660DD5-400200C
				No	KIT 3660DD5-400200X
	255 - 340 A	255 - 340 A	N/A	Yes	KIT 3660DD5-600400C
				No	KIT 3660DD5-600400X
	425 A	425 A	N/A	Yes	KIT 3660DD5-1K0400C
				No	KIT 3660DD5-1K0400X





Input Power Supply & Common Bus Solutions

Common Bus Sharing Diodes

- M3345CBM

Common Bus Isolation Diodes

- M3460D

Bus Filter Capacitance

- M3612

Regenerative DC Bus Power Supplies

- M3545P
- M3645P

3-Phase Power Supplies

- M3713

Single Phase Power Supplies

- M3712

24VDC Power Supplies

- M3699
- M7009





Why Common DC Bus?

Applications that require multiple motors and drives can be configured to use a Common DC bus. This is being done more often, and with good reasons, including:

- Reduced component count
- Energy savings
- Cost savings

By connecting the DC busses of multiple VFDs, power that is being regenerated by a motor in one part of the system can be consumed by a motor that is powering the system. This is a great advantage for applications with motors that are constantly regenerating while others are motoring. This also allows systems to use one Braking Transistor and Resistor (or Line Regeneration Module) for multiple drives when the line is stopping or decelerating.

Cranes, gantries and other motion systems can also benefit from a common braking solution, as there is typically a single large motor with other smaller motors.

To further reduce component count, a power supply can be used with multiple drives to eliminate multiple power supplies in a drive system.

Any industry application that requires the use of multiple electric motors in a system can benefit from the use of a shared common DC bus. The use of a common bus allows for the reduction of wiring and components, as the linked drives can now share components. It can also allow for the direct sharing of power between drives, reducing amount of power needed from the grid. This can be achieved with either a common bus power supply or with diode sharing.

Common Bus Power Supply

M3712, M3713

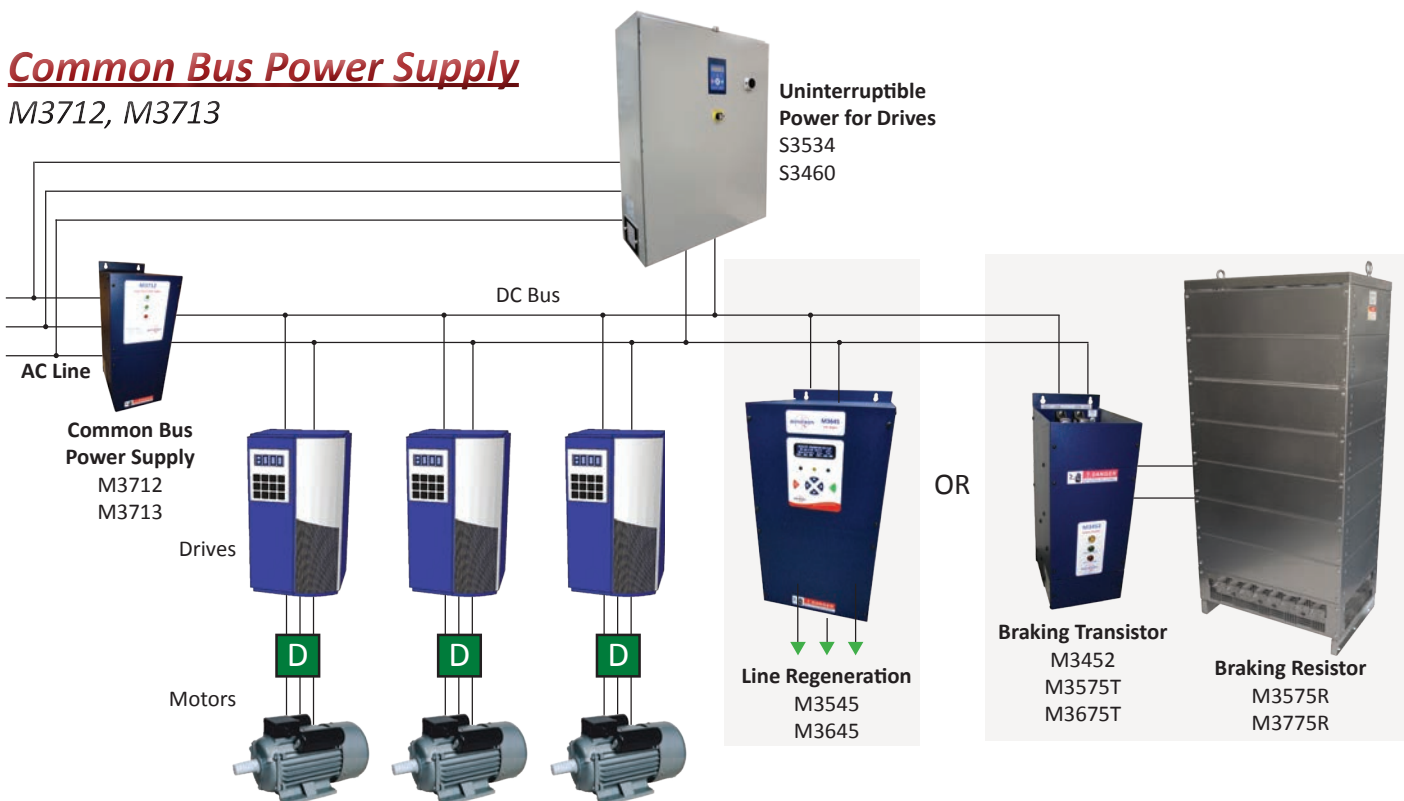

If drives on the AC line are connected by a DC bus, circulating currents can be created that might cause drive faults. Sharing diodes allow a **two way flow of power** to and from drives, enabling them to share power between their DC busses, while preventing circulating currents. The two-way flow allows the drives to share power with each other or use a common braking, regen, or UPD (Uninterruptible Power for Drives) unit. Multiple drives of similar size can be run through a single diode unit while different size drives can be handled with separate diode units.

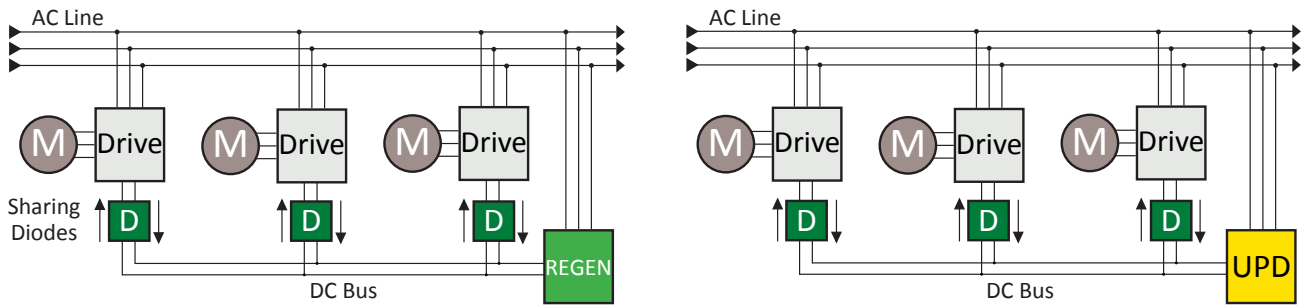

Common DC Bus Filter Capacitance

Extra capacitance (CAP) on the DC Bus with power supply or diode units.

3612EC

- Reduce DC bus ripple from AC conversion

3612RC

- Limit high frequency spikes from switching

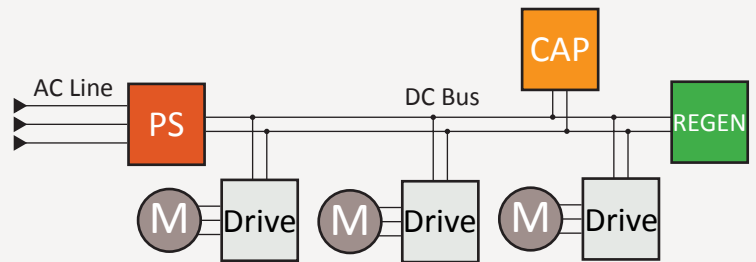

Common Bus Isolation Diodes

Unlike sharing diodes, isolation diodes allow only a **one-way flow of power** and do not allow drives to share power with each other, completely isolating the drives. The isolation diodes allow multiple drives to be connected on the DC bus so that they can share one UPD. The M3460D allows inward flow of power so that one UPD can power all of the drives connected to the DC bus. Multiple drives of similar size can be run through a single diode unit while different size drives can be handled with separate diode units.

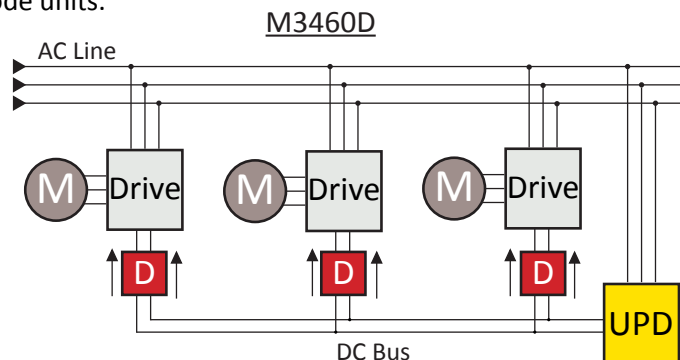



Common Bus Solutions

Drive systems are increasingly being configured with a common DC bus and for good reason. Common DC bus configurations create many advantages including cost savings, greater efficiency, and a more versatile system design.

Multiple drives connected through a common DC bus can share a brake or a UPD resulting in reduced component count and reducing cost. Also, if some drives are overhauling while others are motoring, power from the braking drives can be directly shared with the accelerating drives over the DC bus. Bonitron has diodes that allow your drives to share regenerative energy on a common bus (M3345CBM), or share a common UPD (M3460D) while isolating the drives from each other.

Bonitron common DC bus configuration accessories work with drive systems with DC bus connections.

M3345CBM Series

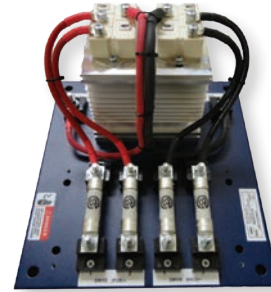

M3460D Series

M3345CBM

	Nominal HP		Max. # of Drives (per unit)	Model Number	Drive Current	Output Current		Dimensions (H x W x D)
	230-240 VAC	460-480 VAC				Peak	Cont.	
	3 HP	5 HP	3	M3345CBM - 10H3	10A	30A	30A	8.50" x 8.50" x 5.50"
			6	M3345CBM - 10J6		60A		8.50" x 15.00" x 5.50"
	10 HP	20 HP	3	M3345CBM - 30H3	30A	90A	30A	8.50" x 8.50" x 5.50"
			6	M3345CBM - 30J6		180A		8.50" x 15.00" x 5.50"
	20 HP	40 HP	2	M3345CBM - 60L2	60A	120A	50A	13.00" x 12.00" x 8.00"
			3	M3345CBM - 60L3		180A		
	20 HP	40 HP	4	M3345CBM - 60P4	60A	240A	100A	15.00" x 24.00" x 8.00"
			6	M3345CBM - 60P6		360A		
	30 HP	60 HP	2	M3345CBM - 90N2	90A	180A	100A	14.00" x 15.00" x 8.00"
			3	M3345CBM - 90N3		270A		
	100 HP	200 HP	2	M3345CBM - 200P2	200A	400A	200A	15.00" x 24.00" x 8.00"
	75 HP	150 HP	1	M3345CBM - 200X1	200A	400A	200A	13.75" x 6.90" x 9.25"
	100 HP	200 HP	1	M3345CBM - 250X1	250A	375A	250A	13.75" x 6.90" x 9.25"
	125 HP	250 HP	1	M3345CBM - 300X1	300A	600A	300A	13.75" x 6.90" x 9.25"
	125 HP	250 HP	1	M3345CBM - 350X1	350A	450A	300A	13.75" x 6.90" x 9.25"

M3460D

	Nominal HP		Max. # of Drives (per unit)	Model Number	Drive Current	Current		Dimensions (H x W x D)
	230-240 VAC	460-480 VAC				Peak	Cont.	
	1.5 HP	3 HP	6	M3460D-6F6-4	4 A	24 A	20 A	8.00" x 12.50" x 5.50"
	3 HP	5 HP	3	M3460D-3H3-10	10 A	30 A	30 A	8.50" x 8.50" x 5.50"
			6	M3460D-6J6-10		60 A		15.00" x 8.50" x 5.50"
	10 HP	20 HP	3	M3460D-3H3-30	30 A	90 A	30 A	8.50" x 8.50" x 5.50"
			6	M3460D-6J6-30		180 A		15.00" x 8.50" x 5.50"
	20 HP	40 HP	2	M3460D-2L2-60	60 A	120 A	50 A	12.00" x 13.00" x 8.00"
			3	M3460D-3L3-60		180 A		
	20 HP	40 HP	4	M3460D-4P4-60	60 A	240 A	100 A	24.00" x 15.00" x 8.00"
			6	M3460D-6P6-60		360 A		
	30 HP	60 HP	2	M3460D-2N2-90	90 A	180 A	100 A	15.00" x 15.00" x 8.00"
			3	M3460D-3N3-90		270 A		
	100 HP	200 HP	2	M3460D-2P2-200	200 A	400 A	200 A	24.00" x 15.00" x 8.00"





M3612EC Series

The M3612EC is a filter capacitor bank for a common DC bus drive systems. The drives can be either servo or variable frequency drives intended for use with common bus capacitors.

- 7,000 - 28,000µF

	System Voltage	Model Number	Max. Capacitor Voltage	Capacitance	ESR	End-of-Life		Max Ripple Current		Dimensions (H x W x D)
						Capacitance Change	ESR Change	@300Hz 45°C	@300Hz 105°C	
	230-240VAC	M3612EC-L280-K7	450VDC	28,000µF	3.8mΩ	-20%	100%	385A	175A	20.00" x 7.12" x 10.30"
	460-480VAC	M3612EC-H070-K7	900VDC	7,000µF	15.3mΩ	-20%	100%	200A	90A	20.00" x 7.12" x 10.30"

M3612RC Series

- Limits voltage spikes on Common Bus Systems -

The M3612RC Common Bus Snubber is a high frequency filter that limits spikes and ringing in DC bus systems caused by inverter switching, supply noise, bus reactance, and other sources. Limiting these spikes protects attached drives and power supplies, preventing premature failure.



	Model Number	Capacitor	Resistor	Chassis	Dimension (H x W x D)
460 - 480VAC					
	M3612RC-H12R20C	2000VDC	12 Ohm	M4	12.75" x 4.00" x 9.00"





Input Power Supply Solutions



M3645P Series

M3545P Series

The M3645P and M3545P Regenerative DC Bus Power Supply synchronizes to the frequency of the incoming power line, allowing it to automatically adapt to 50Hz or 60Hz input. Under normal conditions, the M3645P rectifies the AC line and supplies power to the load. During a braking event, as the DC bus rises above the AC line peak, the M3645P redirects current from the DC bus into the AC line to limit the rise in bus voltage and prevent over-voltage faults. While regenerating the M3645P will automatically fold back in an overcurrent condition, or shut down in the event that unsafe conditions are detected.



Models with precharge are not UL listed

Up to two 100A M3645P units can be run in parallel for high-power applications.

Models with precharge will have -R at the end of the model number.

Phase	Power		Display Type	Model Number	Current		Watt Loss	Dimensions (H x W x D)	Fuse Plate	Reactor
	Cont.	Peak			Model Number	Model Number				
	Line Regen									
208 - 240VAC										
1	0.9 HP	1.4 HP	LEDs	M3545P-L006-M4	2 A	3 A	34 W	14.80" x 4.00" x 8.30"	M3545F-H015	N/A
3	2.8 HP	4.2 HP			6 A	9 A	59 W			
1	2.25 HP	3.5 HP	LEDs	M3545P-L015-M4	5 A	7.5 A	67W	17.00" x 4.70" x 10.80"	M3545F-H015	N/A
3	7 HP	10.5 HP			15 A	22.5 A	117W			
3	14 HP	21 HP	LEDs+Digital	M3645-L030-M10-D	30 A	45 A	180W	20.00" x 10.00" x 10.10"	M3645F-H030	
3	24 HP	36 HP	LEDs+Digital	M3645P-L050-M11-D	50 A	75 A	265W	22.00" x 11.30" x 10.60"	M3645F-H050	
3	48 HP	72 HP	LEDs+Digital	M3645P-L100-M12-D	100 A	150 A	470W	24.00" x 12.00" x 12.10"	M3645F-H100	
3	72 HP	108 HP	LEDs+Digital	M3645P-L150T-M15-D	150 A	225 A	1000W	26.00" x 13.90" x 11.11"	M3645F-H150	M3645-L150R
3	108 HP	160.8 HP	LEDs+Digital	M3645P-L225T-M15-D	225 A	335 A	1500W	26.00" x 13.90" x 11.11"	M3645F-H225	M3645-L225R
3	96 HP	120 HP	LEDs+Digital	M3645P-L300T-M15-D	300 A	375 A	2000W	26.00" x 13.90" x 11.11"	M3645F-H300	M3645-L300R
380 - 415VAC										
3	25 HP	37 HP	LEDs+Digital	M3645-E030-M10-D	30 A	45 A	180W	20.00" x 10.00" x 10.10"	M3645F-H030	
3	41 HP	62 HP	LEDs+Digital	M3645P-E050-M11-D	50 A	75 A	265W	22.00" x 11.30" x 10.60"	M3645F-H050	N/A
3	83 HP	125 HP	LEDs+Digital	M3645-E100-M12-D	100 A	150 A	470W	24.00" x 12.00" x 12.10"	M3645F-H100	
3	125 HP	187.5 HP	LEDs+Digital	M3645P-E150T-M15-D	150 A	225 A	1000W	26.00" x 13.90" x 11.11"	M3645F-H225	M3645-E150R
3	187.5 HP	279.2 HP	LEDs+Digital	M3645P-E225T-M15-D	225 A	335 A	1500W	26.00" x 13.90" x 11.11"	M3645F-H300	M3645-E225R
3	250 HP	312.5 HP	LEDs+Digital	M3645P-E300T-M15-D	300 A	375 A	2000W	26.00" x 13.90" x 11.11"	M3645F-H300	M3645-E300R
460 - 480VAC										
1	1.8 HP	2.8 HP	LEDs	M3545P-H006-M4	2 A	3 A	34 W	14.80" x 4.00" x 8.30"	M3545F-H015	N/A
3	5.6 HP	8.4 HP			6 A	9 A	59 W			
1	4.5 HP	7 HP	LEDs	M3545P-H015-M4	5 A	7.5 A	67W	17.00" x 4.70" x 10.80"	M3545F-H015	N/A
3	14 HP	21 HP			15 A	22.5 A	117W			
3	28 HP	43 HP	LEDs+Digital	M3645P-H030-M10-D	30 A	45 A	180W	20.00" x 10.00" x 10.10"	M3645F-H030	
3	48 HP	72 HP	LEDs+Digital	M3645P-H050-M11-D	50 A	75 A	265W	22.00" x 11.30" x 10.60"	M3645F-H050	
3	96 HP	144 HP	LEDs+Digital	M3645P-H100-M12-D	100 A	150 A	470W	24.00" x 12.00" x 12.10"	M3645F-H100	
3	144 HP	216 HP	LEDs+Digital	M3645-H150T-M15-D	150 A	225 A	1000W	26.00" x 13.90" x 11.11"	M3645F-H150	M3645-H150R
3	216 HP	321.6 HP	LEDs+Digital	M3645P-H225T-M15-D	225 A	335 A	1500W	26.00" x 13.90" x 11.11"	M3645F-H225	M3645-H225R
3	288 HP	360 HP	LEDs+Digital	M3645-H300T-M15-D	300 A	375 A	2000W	26.00" x 13.90" x 11.11"	M3645F-H300	M3645-H300R
575 - 600VAC										
3	36 HP	54 HP	LEDs+Digital	M3645-C030-M10-D	30 A	45 A	180W	20.00" x 10.00" x 10.10"	M3645F-C030	
3	60 HP	90 HP	LEDs+Digital	M3645P-C050-M11-D	50 A	75 A	265W	22.00" x 11.30" x 10.60"	M3645F-C050	N/A
3	120 HP	180 HP	LEDs+Digital	M3645P-C100-M12-D	100 A	150 A	470W	24.00" x 12.00" x 12.10"	M3645F-C100	



Using a common bus power supply reduces the amount of wiring and components in a system, resulting in a reduction of maintenance and footprint of the system. In a system with multiple motors, some motors may be regenerating while others are motoring. The common bus allows the regenerating drives to share power with the motoring drives, thus reducing the amount of power needed from the grid. If the drives are creating a net surplus of energy, a single line regen or braking unit can be installed to dissipate the excess energy.

A common bus power supply can also allow the use of single phase AC power with 3-phase motors without having to oversize the drive. The M3712 can create a common DC bus from single phase power while the M3713 uses 3-phase input power.

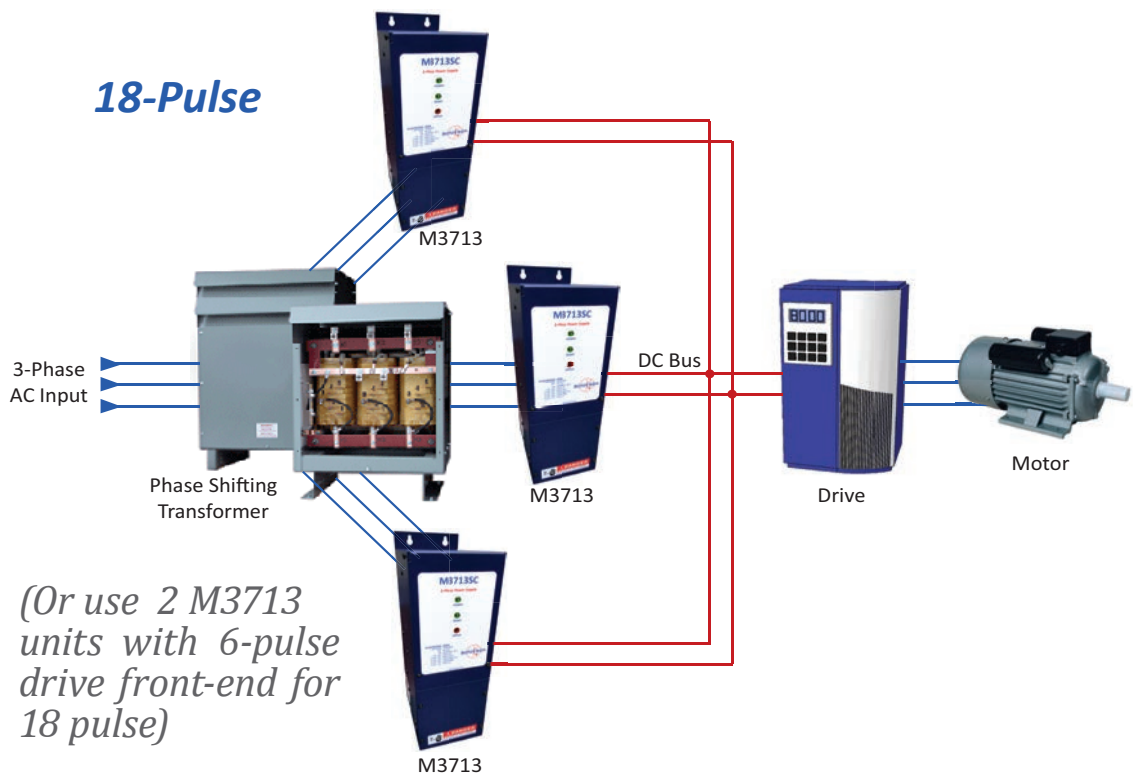

12 & 18 Pulse Solutions

Model Number	6-PULSE (One Unit)		12-PULSE (Two Units)		18-PULSE (Three Units)		
	Nominal Drive HP	DC Output Current (Amps)	Nominal Drive HP	DC Output Current (Total Amps)	Nominal Drive HP	DC Output Current (Total Amps)	
230 - 240VAC							
M3713SC-L30-B5	7.5	30	12.5	55	20	80	
M3713SC-L75-B5	20	75	35	135	50	200	
M3713SC-L150-K7	50	150	90	270	135	400	
M3713SC-L225-K7	75	225	135	405	200	600	
M3713SC-L375-K10	125	375	225	675	335	1000	
460 - 480VAC							
M3713SC-H30-B5	15	30	25	55	40	80	
M3713SC-H75-B5	40	75	70	135	100	200	
M3713SC-H150-K7	100	150	180	270	270	400	
M3713SC-H225-K7	150	225	270	405	400	600	
M3713SC-H375-K10	250	375	450	675	675	1000	



Input Power Supply Solutions

The Bonitron M3713 series is a non-regenerative AC to DC rectifier that can serve as the main power supply for your common bus DC system.

Drive systems are more commonly being configured with a common DC bus; for good reason. Common DC bus configurations create advantages including:

- Cost savings
- Greater efficiency
- More versatile system design

One method of creating a common bus systems is the use of a rectifier that supplies DC power to all of the drives instead of individual rectifiers for each drive. The Bonitron M3713 is the ideal solution for this method.

Multiple M3713 Power Supplies can be used in parallel for high power applications, as well as for redundancy and increased process reliability.

The M3713 can also be used as a building block for 12 and 18 pulse systems using standard VFDs. These systems mitigate harmonics and other power quality issues. **Multiple M3713 units used with a phase shifting transformer allows standard drives to meet IEEE 519 compliance.**



M3713 Series



Specifications

M3713SC (with precharge)

M3713DM (without precharge)

230-240 VAC, 460-480 VAC, 575-600 VAC	Input Voltage	230-240 VAC, 460-480 VAC, 575-600 VAC
150% Full Load Rating for 60 seconds	Intermittent duty Limit	150% Full Load Rating for 60 seconds
20% Full Load Rating	Precharge Ramp Current Limit	N/A
175% Full Load Rating	Overload Limit	N/A
24V+ Sinking Precharge Enable Run Enable	Control Inputs	N/A
250VAC, 120mA Max Precharge Complete Ready	Control Outputs	250VAC @ 120mA 110VAC @ 500mA Overtemp (NC)
Power, Ready, Status	Indicators	Power





Model Number Selection

Up to 3 units can be in parallel for higher current requirements.

	Power (Nominal)	Precharge	Model Number	Output Current	Dimensions (H x W x D)
208 - 240 VAC					
	7.5 HP	NO	M3713DM-L030-B5	30 A	17.75" x 5.50" x 7.80"
		YES	M3713SC-L030-B5		
	20 HP	NO	M3713DM-L075-B5	75 A	17.75" x 5.50" x 7.80"
		YES	M3713SC-L075-B5		
	50 HP	NO	M3713DM-L150-K7	150 A	20.00" x 7.12" x 10.35"
		YES	M3713SC-L150-K7		
	75 HP	NO	M3713DM-L225-K7	225 A	20.00" x 7.12" x 10.35"
		YES	M3713SC-L225-K7		
	125 HP	NO	M3713DM-L375-K10	375 A	20.00" x 10.00" x 10.50"
		YES	M3713SC-L375-K10		
380 - 415 VAC					
	12 HP	NO	M3713DM-E030-B5	30 A	17.75" x 5.50" x 7.80"
		YES	M3713SC-E030-B5		
	32 HP	NO	M3713DM-E075-B5	75 A	17.75" x 5.50" x 7.80"
		YES	M3713SC-E075-B5		
	80 HP	NO	M3713DM-E150-K7	150 A	20.00" x 7.12" x 10.35"
		YES	M3713SC-E150-K7		
	120 HP	NO	M3713DM-E225-K7	225 A	20.00" x 7.12" x 10.35"
		YES	M3713SC-E225-K7		
	200 HP	NO	M3713DM-E375-K10	375 A	20.00" x 10.00" x 10.50"
		YES	M3713SC-E375-K10		
460 - 480 VAC					
	15 HP	NO	M3713DM-H030-B5	30 A	17.75" x 5.50" x 7.80"
		YES	M3713SC-H030-B5		
	40 HP	NO	M3713DM-H075-B5	75 A	17.75" x 5.50" x 7.80"
		YES	M3713SC-H075-B5		
	100 HP	NO	M3713DM-H150-K7	150 A	20.00" x 7.12" x 10.35"
		YES	M3713SC-H150-K7		
	150 HP	NO	M3713DM-H225-K7	225 A	20.00" x 7.12" x 10.35"
		YES	M3713SC-H225-K7		
	250 HP	NO	M3713DM-H375-K10	375 A	20.00" x 10.00" x 10.50"
		YES	M3713SC-H375-K10		
575 - 600 VAC					
	20 HP	NO	M3713DM-C030-B5	30 A	17.75" x 5.50" x 7.80"
		YES	M3713SC-C030-B5		
	50 HP	NO	M3713DM-C075-B5	75 A	17.75" x 5.50" x 7.80"
		YES	M3713SC-C075-B5		
	125 HP	NO	M3713DM-C150-K7	150 A	20.00" x 7.12" x 10.35"
		YES	M3713SC-C150-K7		
	175 HP	NO	M3713DM-C225-K7	225 A	20.00" x 7.12" x 10.35"
		YES	M3713SC-C225-K7		
	300 HP	NO	M3713DM-C375-K10	375 A	20.00" x 10.00" x 10.50"
		YES	M3713SC-C375-K10		





Input Power Supply Solutions

The M3712 Single Phase Power Supply is a low-cost solution for powering 3-phase AC drives from a single phase source.

3-phase motors are the economical choice for motor applications above 10 horsepower, however many locations only have single phase power available due to the cost of expanding 3-phase availability. Most VFDs are not designed for single phase operation, and even those that are must be oversized by up to 300% when operated from a single phase source.

Fortunately, there is no longer a need to oversize 3-phase drives when using them in single phase applications thanks to the Bonitron M3712 Single Phase Power Supply. The M3712 has a single phase AC input and serves as a power supply for one or multiple drives via DC bus terminal connections. In addition, the M3712 aids in protecting your drive from the high currents caused by single phase operation, which allows your drive to run cooler and longer.



M3712
Series

Specifications

Overload Limit	150% Full Load Rating for 60 seconds
Precharge Ramp Current Limit	20% Full Load Rating
Overcurrent Limit	200% Full Load Rating
Operating Temp	Derate unit 1% per every 1°C above 40°C
Storage Temp	-20 to +65 °C
Control I/O	Inputs: Enable Outputs: Ready
Indicators	Power, Ready, Status

Product Highlights

- Power one or multiple 3-phase drives from single phase source
- No need to de-rate drive for single phase operation
- Power drives via DC +/- connection
- Added bus capacitance and filtering
- Soft start-up to drives for increased reliability
- UL Listed
- Integrated pre-charge

Line Reactor Required. Available from Bonitron.

	Power (Nominal)	Model Number	Output Current	Input Current (AC RMS)	Dimensions (H x W x D)
208 - 240 VAC Drives					
	15 HP	M3712-L015	50 A	87 A	15.00" x 6.20" x 7.30"
	30 HP	M3712-L030	100 A	175 A	20.00" x 7.12" x 10.30"
	50 HP	M3712-L050	160 A	285 A	20.00" x 7.12" x 10.30"
	75 HP	M3712-L075	290 A	550 A	25.00" x 10.00" x 10.20"
	125 HP	M3712-L125	360 A	670 A	32.10" x 14.00" x 12.20"
460 - 480 VAC Drives					
	15 HP	M3712-H015	28 A	58 A	15.00" x 6.20" x 7.30"
	30 HP	M3712-H030	55 A	115 A	20.00" x 7.12" x 10.30"
	50 HP	M3712-H050	90 A	185 A	20.00" x 7.12" x 10.30"
	75 HP	M3712-H075	135 A	250 A	25.00" x 10.00" x 10.20"
	125 HP	M3712-H125	200 A	365 A	32.10" x 14.00" x 12.20"



M3699
Series



The M3699 Voltage Limiter accepts input voltages of 90 – 1000VDC and outputs 175VDC, acceptable to many common 24VDC power supplies. This allows the use to commonly available, off-the-shelf power supplies with years of field exposure in new applications.

Voltage Limiter

Product Highlights

- Low-cost enhancement for 24-volt power supplies
- DIN rail mounting
- 90 - 1000VDC Input
- 175VDC Output Clamped
- 135W Output

Specifications

Input Voltage.....90 - 1000 VDC
 Output Voltage.....175 VDC Clamped
 Power.....135 W
 Indicators.....Status LED

Solar Array or Battery String

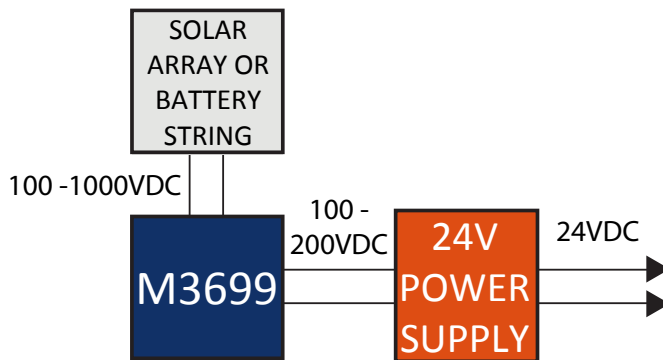

Model Number	Input Voltage	Output Voltage	Output Power	Dimensions (H x W x D)
M3699-135W-DIN	90 - 1000VDC	175VDC	135W	5.90" x 3.80" x 1.90"





Input Power Supply Solutions

24VDC Buffer Module

Bonitron M7009 is a cost-effective solution for protecting your 24-volt DC bus from short-duration outages.

During normal operation, the unit charges slowly from the 24V bus, fully charging in under one minute, with a peak charge current of under 400 mA. Once charged, the unit draws no power from the 24V bus.

During an outage, the module supports the 24V bus for a period depending on the power draw and minimum acceptable voltage of your load.



M7009 Series

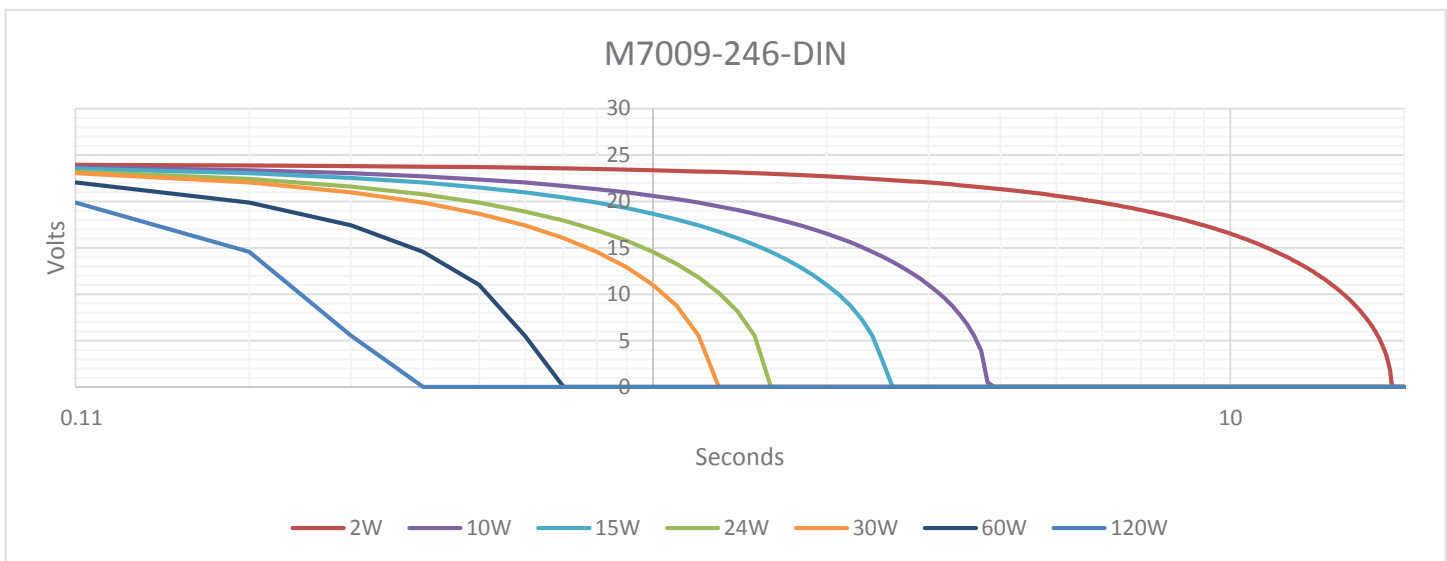

Model Number	Max Operating Voltage	Capacitance	Dimensions (H x W x D)	Wire Gauge
M7009-243-DIN	32VDC	24VDC	8.62" x 4.62" x 2.44"	16-24 AWG
M7009-246-DIN	32VDC	24VDC	8.62" x 4.62" x 2.44"	16-24 AWG
M7009-249-DIN	32VDC	24VDC	8.62" x 4.62" x 2.44"	16-24 AWG



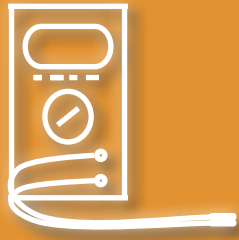

Maintenance Solutions

Portable Capacitor Former

- M3628PCF

Automatic Capacitor Former

- M3628ACF

Portable Ultracapacitor Tester

- M3628PUT

Regen Energy Monitor

- M3660REM





Maintenance Solutions

Why Bonitron Maintenance Solutions?

Bonitron offers maintenance solutions that allow you to charge, discharge, form, and test energy storage.

Test your capacitors to see when they are approaching their "end of life" and replace them before an unnecessary and expensive failure occurs. If you have capacitors that have been stored for a while, reform them with our M3628PCF Portable Capacitor Former to avoid damage to your drive at start up.

A great benefit of many of Bonitron's Maintenance Solutions is portability - making testing and maintenance more convenient!

Portable Capacitor Former

M3628PCF

When variable frequency drives are stored for long periods (typically over eight months), the internal chemistry of their capacitors may begin to deteriorate and need to be reformed prior to use. If the capacitors are not reformed before the drive is put into use, the capacitors have the potential to fail which can cause extensive damage to the drive.

Product Highlights

- Charges, discharges, and forms capacitors
- Manually variable output voltage: 0 - 900 VDC
- Digital voltage and current displays
- Overcurrent and over temperature protection
- Tough impact and weather resistant case



M3628PCF

M3628PCF Selection

	Model Number	Input Voltage	Max Output Voltage	Max Output Current	Max Load Capacitance	Weight
	M3628PCF-C01-110	110 - 120 VAC	900 VDC	1 ADC	100000 uF	65 LBS
	M3628PCF-C01-220	220 - 240 VAC				



Automatic Capacitor Former & Ultracapacitor Tester

M3628ACF & M3628PUT



**Maintenance
Solutions**

As electrolytic capacitors' age approach end-of-life, their capacitance drops significantly below their original specification. These capacitors typically need replacement to avoid process failure. Measuring the actual capacitance helps determine when these capacitors reach EOL (end of life), avoiding both process failure and expensive, unnecessary preemptive replacement.



M3628ACF

Product Highlights

- Charges, discharges, measures, and forms capacitors
- Variable output voltage: 0 - 1000 VDC
- Digital LCD display
- Portable - case on wheels
- Operates from standard 120 VAC supply

M3628ACF Selection

	Model Number	Input Voltage	Output Voltage	Output Current	Max. Capacitance
	M3628ACF-Y01-120	120VAC	1000 VDC	0-1 ADC	300,000 μ F
	M3628ACF-Y01-240	240VAC	1000 VDC	0-1 ADC	300,000 μ F

As ultracapacitors age, their Equivalent Series Resistance rises and their capacitance drops significantly below their original specification. These ultracapacitors typically need replacement to avoid process failure. Measuring the capacitance and Equivalent Series Resistance helps determine when these capacitors reach their end of life, avoiding both process failure and expensive, unnecessary preemptive replacement.

The Bonitron M3628PUT allows the user to charge a capacitor or bank to a specified voltage, and then discharge the bank. The display will then show the calculated capacitance and Equivalent Series Resistance of the bank.



M3628PUT

Product Highlights

- Variable output voltage 0 - 130VDC
- Digital control interface
- Accurate capacitance and equivalent series resistance measurements
- Overcurrent and over-temperature protection

M3628PUT Selection

	Model Number	Input Voltage	Output Voltage	Output Current	Min. Load Capacitance	Max. Load Capacitance
	M3628PUT-U07-110	110 - 120 VAC	0 - 130 VDC	1 - 7 ADC	1 F	500 F
	M3628PUT-U07-220	220 - 240 VAC				



www.bonitron.com



615-244-2825

info@bonitron.com





Maintenance Solutions

When variable speed drive systems are braking, they generate power that must be dissipated. If the excess energy is not dissipated, the drive system can lose control of the process due to an overvoltage trip, or must extend the braking time to keep from overpowering the drive. The traditional method of dissipating excess energy is burning the energy off in a resistor, but resistors take up significant amounts of space and generate an abundance of heat.

The M3660REM Regenerative Energy Monitor is designed to monitor the voltage and current of the resistor to calculate the total energy dissipated across the resistor. The resulting data can be used to size a Bonitron Line Regen to replace the resistor and minimize heat loss, shrink footprint, and return the energy to the AC line.

M3660REM



Simple Connection

1. Hook the REM up to the resistor connections, clamp current clamp around one lead.
2. Run the drive thru cycle for each type of varying lead.

Product Highlights

Will record for each braking event:

- Total length
- Peak current
- Total energy(in joules)
- Peak power

M3660REM Selection

Model Number	Drive AC Voltage	Max Monitoring Voltage	Max Monitoring Current	Weight
M3660REM-C2000	208 - 600 VAC	1000 VDC	2000 ADC	10 LBS



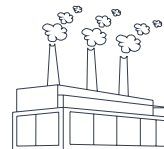

Industry Solutions



Agriculture



Boilers



Centrifuges



Common DC Bus



Cranes & Hoists



HVAC



Logging & Sawmill



Marine

Additional Industries...

No matter what industry your AC drive and motor support, Bonitron has the solution to enhance your process and increase uptime.

While our industry brochures above reflect completed app notes, the items below are a sampling of additional industries Bonitron serves. Feel free to contact us to discuss your application as we continue to build application notes for additional processes and industries.

- Automotive
- Chemical Processing
- Critical Data
- Entertainment/ Stages
- Fiber
- Food Processing
- Metals
- Mining
- Packaging
- Paper
- Petrochemical
- Pharmaceutical
- Recycling
- Semiconductor
- Security
- Textiles
- Transportation
- Water/ Wastewater
- + Many more!

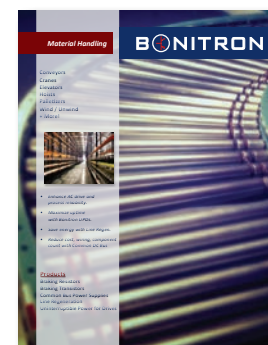

Material Handling



Oil & Gas



DOWNLOAD INSTRUCTION MANUALS AT

BONITRON.COM/SUPPORT



BONITRON.COM/SUPPORT

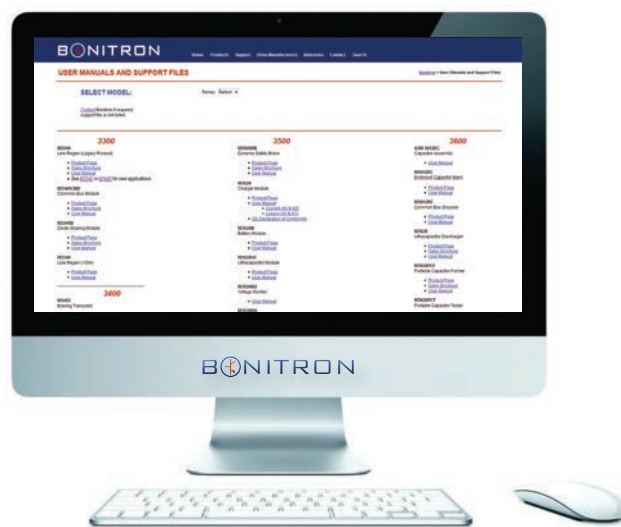

PRODUCT SUPPORT

*Please provide the following
when contacting Bonitron:*

- Full Model Number
- Drive Power
- Serial Number
- Application



www.bonitron.com



615-244-2825

info@bonitron.com



Motor Application Formulas

Calculating Horsepower

Once the machine torque requirement is determined, horsepower can be calculated using the formula:

$$HP = \frac{T \times N}{5,250}$$

where,

HP = Horsepower

T = Torque (ft-lb)

N = Base speed of motor (rpm)

If the calculated horsepower falls between standard available motor ratings, select the higher available horsepower rating. It is good practice to allow some margin when selecting the motor horsepower.

For many applications, it is possible to calculate the horsepower required without actually measuring the torque required. The following useful formulae will help:

Conveyors

$$HP \text{ (Vertical)} = \frac{\text{Weight (lb)} \times \text{Velocity (FPM)}}{33,000}$$

$$HP \text{ (Horizontal)} = \frac{\text{Weight (lb)} \times \text{Velocity (FPM)} \times \text{Coefficient of Friction}}{33,000}$$

Web Transport Systems and Surface Winders

$$HP = \frac{\text{Tension (lb)} \times \text{Velocity (FPM)}}{33,000}$$

Note: The tension value used in this calculation is the actual web tension for surface winder applications. For sectional drives, it is the tension differential: downstream tension – upstream tension.

Center Winders (Control to Base Speed Only)

$$HP = \frac{\text{Tension (lb)} \times \text{Line Speed (FPM)} \times \text{Buildup}}{33,000 \times \text{Taper}}$$

Center Winders (Field Control)

If Taper x Field Range \geq Buildup, then,

$$HP = \frac{\text{Tension (lb)} \times \text{Line Speed (FPM)}}{33,000}$$

If Taper x Field Range \leq Buildup, then,

$$HP = \frac{\text{Tension (lb)} \times \text{Line Speed (FPM)} \times \text{Buildup}}{33,000 \times \text{Taper} \times \text{Field Range}}$$

NOTE: The preceding formulas for calculating horsepower do not include any allowance for machine function windage or other factors. These factors must be considered when selecting a drive for a machine application.

Fans and Blowers

$$HP = \frac{\text{CFM} \times \text{Pressure (lb/ft}^2\text{)}}{33,000 \times \text{Efficiency of Fan}}$$

Effect of Speed on HP:

$HP = K_1 \text{ (RPM)}^3$ — Horsepower varies as the 3rd power of power of speed.

$T = K_2 \text{ (RPM)}^2$ — Torque varies as the 2nd power of speed

$\text{Flow} = K_3 \text{ (RPM)}$ — Flow varies directly as the speed

$$HP = \frac{\text{CFM} \times \text{Pressure (lb/in}^2\text{)}}{229 \times \text{Efficiency of Fan}}$$

$$HP = \frac{\text{CFM} \times \text{Inches of Water Gauge}}{6356 \times \text{Efficiency of Fan}}$$

Pumps

$$HP = \frac{\text{GPM} \times \text{Head (ft)} \times \text{Specific Gravity}}{3960 \times \% \text{ Efficiency of Pump}}$$

Specific Gravity of Water = 1.0

1 ft³ per sec. = 448 GPM

1 PSI = A head of 2.309 ft for water weighing 62.36 lb/ft³ at 62°F

Constant Displacement Pumps

Effect of Speed on HP:

$HP = K \text{ (RPM)}$ — Horsepower and capacity vary directly as the speed.

Displacement pumps under constant head require approximately constant torque at all speeds.

Centrifugal Pumps

Effect of Speed on HP:

$HP = K_1 \text{ (RPM)}^3$ — Horsepower varies as the 3rd power of speed.

$T = K_2 \text{ (RPM)}^2$ — Torque varies as the 2nd power of speed.

$\text{Flow} = K_3 \text{ (RPM)}$ — Flow varies directly as the speed.

Efficiency:

500 to 1,000 gal/min = 70% to 75%

1,000 to 1,500 gal/min = 75% to 80%

Larger than 1,500 gal/min = 80% to 85%

Displacement pumps may vary between 50% and 80% efficiency, depending on size of pumps.



Electrical Formulas

Ohms Law

$$\text{Amperes} = \frac{\text{Volts}}{\text{Ohms}} \quad \text{or} \quad \text{Ohms} = \frac{\text{Volts}}{\text{Amperes}}$$

$$\text{or} \quad \text{Volts} = \text{Amperes} \times \text{Ohms}$$

Power in DC Circuits

$$\text{Horsepower} = \frac{\text{Volts} \times \text{Amperes}}{746}$$

$$\text{Watts} = \text{Volts} \times \text{Amperes}$$

$$\text{Kilowatts} = \frac{\text{Volts} \times \text{Amperes}}{1,000}$$

$$\text{Kilowatt-Hours} = \frac{\text{Volts} \times \text{Amperes} \times \text{Hours}}{1,000}$$

Power in AC Circuits

Kilovolt-Amperes (KVA):

$$\text{kVA (1}\phi\text{)} = \frac{\text{Volts} \times \text{Amperes}}{1,000}$$

$$\text{kVA (3}\phi\text{)} = \frac{\text{Volts} \times \text{Amperes} \times 1.73}{1,000}$$

Kilowatts (Kw)

$$\text{kVA (1}\phi\text{)} =$$

$$\text{kVA (3}\phi\text{)} = \frac{\text{Volts} \times \text{Amperes} \times \text{Power Factor} \times 1.73}{1,000}$$

$$\text{Power Factor} = \frac{\text{Kilowatts}}{\text{Kilovolts} \times \text{Amperes}}$$

Kilovolt Amperes:

Single Phase

$$\text{KVA} = \frac{E \times I}{1,000}$$

Two Phase - *(4 - wire)

$$\text{KVA} = \frac{2 \times E \times I}{1,000}$$

Three Phase

$$\text{KVA} = \frac{1.73 \times E \times I}{1,000}$$

Horsepower Output:

Single Phase

$$\text{HP} = \frac{E \times I \times \text{Eff} \times \text{PF}}{746}$$

Two Phase - *(4 - wire)

$$\text{HP} = \frac{2 \times E \times I}{746}$$

Three Phase

$$\text{HP} = \frac{1.73 \times E \times I \times \text{Eff} \times \text{PF}}{746}$$



Contact Us

Bonitron has developed thousands of products since 1962. With an educated and experienced Engineering Team, Bonitron is able to work with customers on both standard and custom applications and projects.

If you don't see what you need, call us and we'll work together to create a solution to fit your needs!



FOUNDED 1962

WWW.BONITRON.COM

- Model Selection Tables
- Sales Brochures
- User Manuals and Drawings
- Industry Applications
- Application Notes
- + More!

INFO@BONITRON.COM

- Sizing and Technical Support
- Customer Service
- Purchase Orders

615-244-2825

- Sizing and Technical Support
- Customer Service

141021 20180810