



AMO

CORPORATE PROFILE
TRUSTED INNOVATION

Advanced Material On technology is AMO Group's competitiveness in the world market

☑ AMO's Core Materials

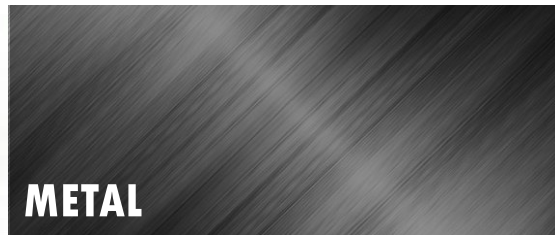

Amorphous

Shielding Materials

Nano Powder



Dielectric Ceramic

Piezo Electric Ceramic

LTCC/HTCC

Graphite

Ferrite Sheet



Nano Fiber

TIM

The AMO Group dominates the global market with its unique technological process, claiming its reputation as a Hidden Champion company

330 Million(USD) **Sales in 2018**

6 products

**World Best Product
in 2019**

34 Million(USD) **R&D expenses in 2018**

3,023 patents

**Patents as of
December 31, 2018**

1,405 employees **Employees as of
December 31, 2018**

12 factories

Production Site



It makes innovation to reality that 28 Division specialized in their own technology

AMO Group

AMOTECH	AMOGREENTECH		AMOSENSE	AMOLIFESCENCE
EMC	Magnetic Component	Nano Fiber	Wireless Charging	Bio Device
Antenna	Flexible Battery	Thermal Magnetic EMI	Substrate & Package	AMO Skin
Motor	Vent	Thin-film PCB	Module	Nano-mag
	AMO Plant	PCB	LED Lighting	Stem Cell
	Force Touch	Metal-Graphite	5G	Bio Medical
	ESS	Metallic Converter	IoT Device	
	Water Treatment	Smart Clean Window	Sigfox Operator	

AMO guarantees the stable stream of production and on-time supply with its ten globally-certified production facilities across the world and 643 supply networks

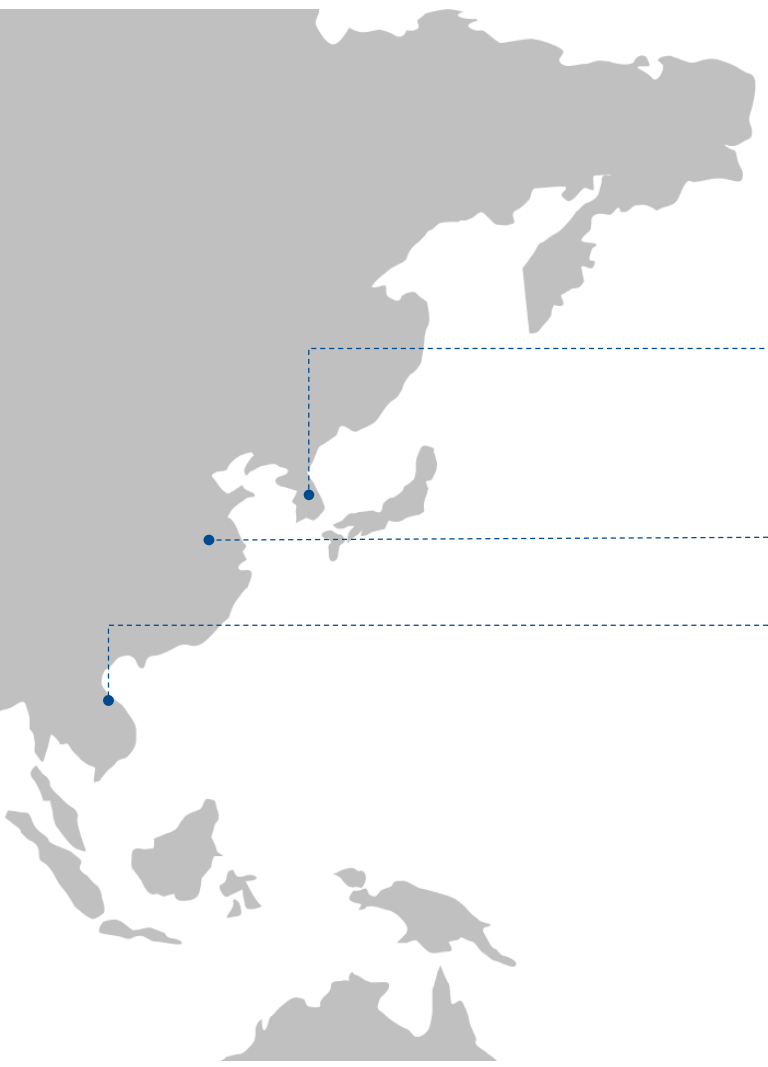

✓ Domestic and Foreign Production Facilities

Country	Established	City	No. of Employees
1 Korea	1994	Kimpo Tongjin	43
	2000	Kimpo Hasung	98
	2003	Inchon	660
	2007	Pyong-taek	198
	2008	Chonan Factory 1	103
	2012	Chonan Factory 2	75
	2017	Cheorwon	8
	2018 (Scheduled)	Geomdan	-
2 China	2003	Zibo Factory 1	360
	2007	Zibo Factory 2	280
	2006	Qingdao	257
3 Vietnam	2014	Hanoi Factory 1	564
	2018	Hanoi Factory 2	615
Total	-	12 factories	3,261

✓ Compliance with the ISO Quality Certification



AMOGREENTECH

Advanced Materials Technologies

The high efficiency magnetic material
for Renewable energy

Since 1994, Amogreentech has manufactured Amorphous, Nano-crystalline strip, and magnetic inductive parts such as Mag-Amp Core, Cut Core, Noise Protection Core

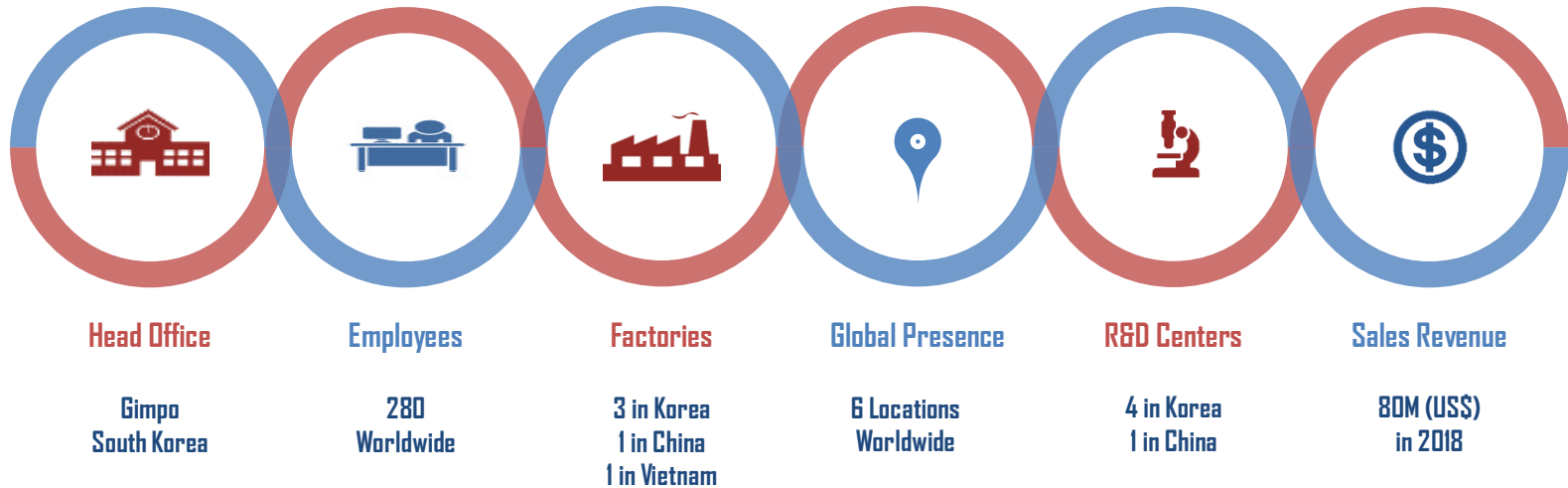

➔ CEO

➔ S. C. Yang

➔ History

➔ Established in 2004, acquired TS16949 certification in 2012
Corporation listing on KOSDAQ in 2019

➔ Globalization

➔ Established Amogreentech China in 2006
Established a new factory in Vietnam in 2018

Amogreentech has expanded our impact on the Future market based on three main strengths

Key Direction

 High Efficiency  Cost effective  Customizing

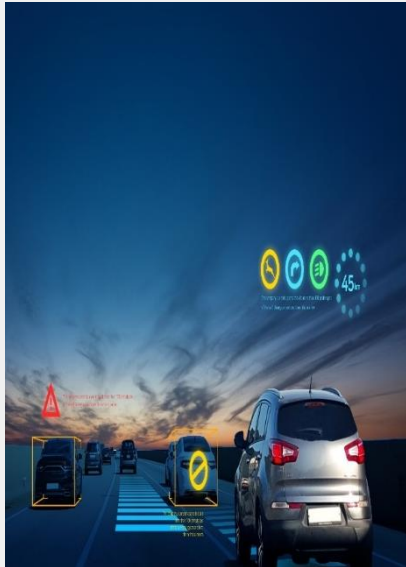

Automotive



5G



Solar & ESS

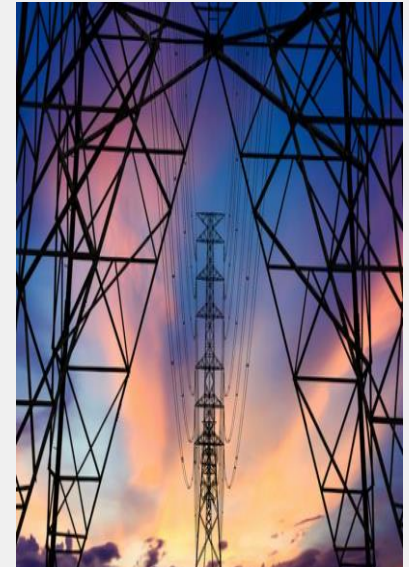

Smart grid

Magnetic components for Inductor(Coil), EMI Filter, Current sensor

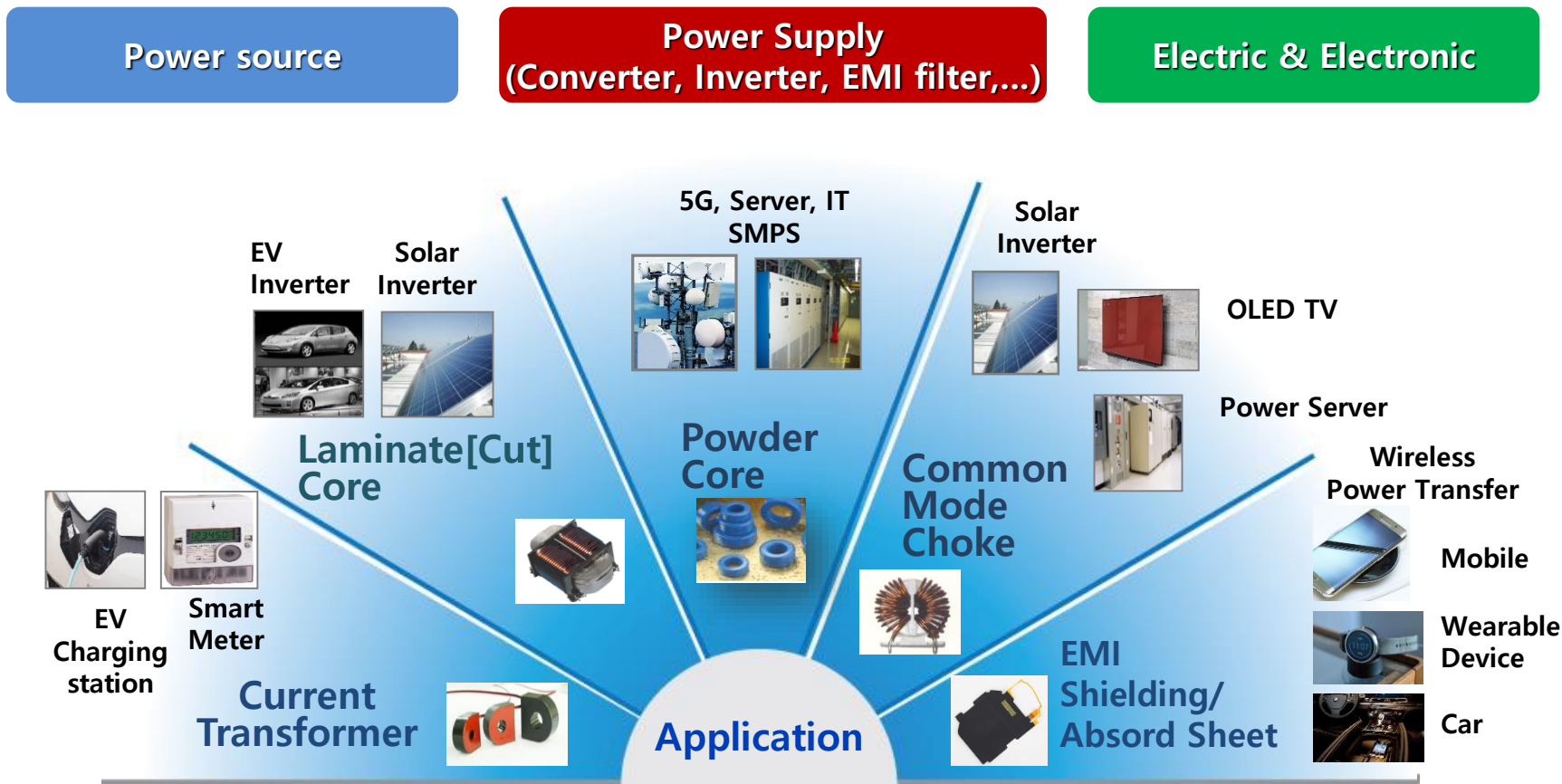

Amorphous core is used as choke for filtering EMI and regulating voltage in the power circuit

AC Input Stage

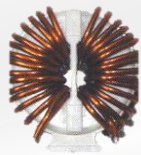

Common Mode Choke
-Noise filtering

AMFN™ series
AMCA™ series

DC Output Stage



Mag-Amp Cores
- Voltage regulation

AMSA™ series
AMSNTM™ series

PFC Input Stage

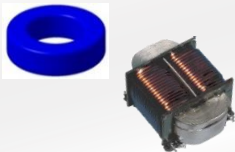

PFC Choke Core
-Voltage boosting

APM & APHTM™ series
AMLB & AMCU™ series

Output Stage



Output Choke Core
-DC Ripple control

APM & APHTM™ series
AMLB & AMCU™ series

Primary Switch & Diode Protection

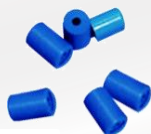

Spike Killer & Bead
-S/W noise suppression

AMB™ series

AC Current Sensing & Monitoring



Current Transformer

AST™ Series
ASM & ASD™ Series

What is Amorphous materials?

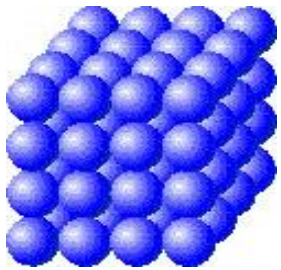

(a) crystalline

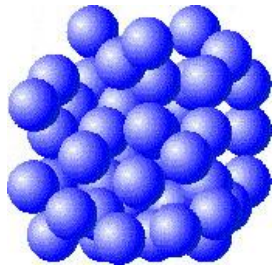

(b) amorphous

Atomic structure

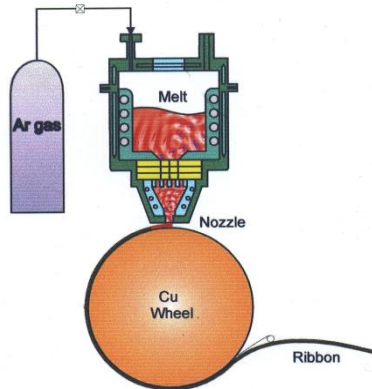

Manufacturing process

Characteristics

- Non crystalline anisotropy
- Random atomic structure
- Thin strip (about 0.020~0.025mm)

- High permeability
- Low core loss
- Low eddy current loss

- Smaller size and less weight in design
- Connect to Energy saving
- Improving efficiency

1) Common Mode Choke core

Solution for EMC



Nano-crystalline amorphous material

- **High Permeability**
 - ✓ Low phase & amplitude error
 - ✓ EMI Noise reduction effect
- **High magnetic flux density**
 - ✓ Wide measurement range of current with small volume
 - ✓ High DC current use
 - ✓ High Efficiency
- **Low temperature dependence of permeability**

※ Composition of material(at%)

- **Nano-crystalline**
 - $Fe_{73.5} Cu_{1.0} Nb_{3.0} Si_{13.5} B_{9.0}$
- **Fe-based amorphous**
 - $Fe_{78.0} Si_{9.0} B_{13.0}$

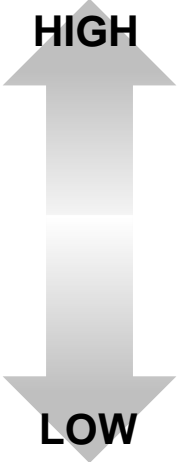
Level	Permeability	Magnetic Flux Density	Core Loss, P_{cv} [mw/cm ³] @ 100 kHz, 0.1 T
	Nano-crystalline (~180,000)	Si-Steel (~1.7T)	Iron powder (2000~)
	Permalloy (~60,000)	Nano-crystalline (~1.2T)	6.5% Fe-Si (1500~)
	Ferrite (~10,000)	Permalloy (~0.7T)	Sendust (700~1000)
	Si-Steel (~5,000)	Ferrite (~0.4T)	High Flux (1300-1500)
	-	-	Nano-crystalline (400~500)

AMFN-series

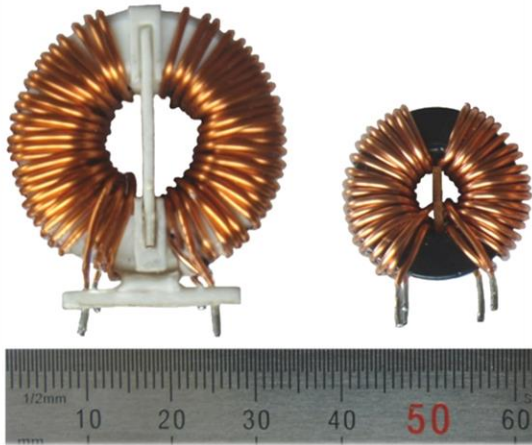
FERRITE
AMFN - series

$$L = A_L \cdot N^2 = \mu \cdot \left(\frac{A}{l}\right) \cdot N^2$$

✓ **Size reduction**

✓ **Cooper Loss Reduction**

Application

- EMI / EMC common mode filtering
- Telecommunications
- Data communications interface transformers
- High accuracy current transformers
- High accuracy pulse transformers
- Ground fault protection devices

Features

- High permeability
- Compact in size
- Reduce the winding turns
- Low DC resistance
- High impedance overall the wide-range of frequency
- Meet the EN 500081 and EN 500082 standards
- Low profile (1 ~ 5 mm height)

Strength of AMFN-series

- ▶ Reduction of size and winding turns
- ▶ Rapid responsive development
- ▶ Price competitiveness

Parameters	AMFN	Ferrite
Permeability(μ)	80,000~100,000	10,000
Size	Small	Big
No. of Turns	Fewer	More
Core loss	Low	Low
High Impedance Range	Wide	Narrow
Operating Temperature	High	Low

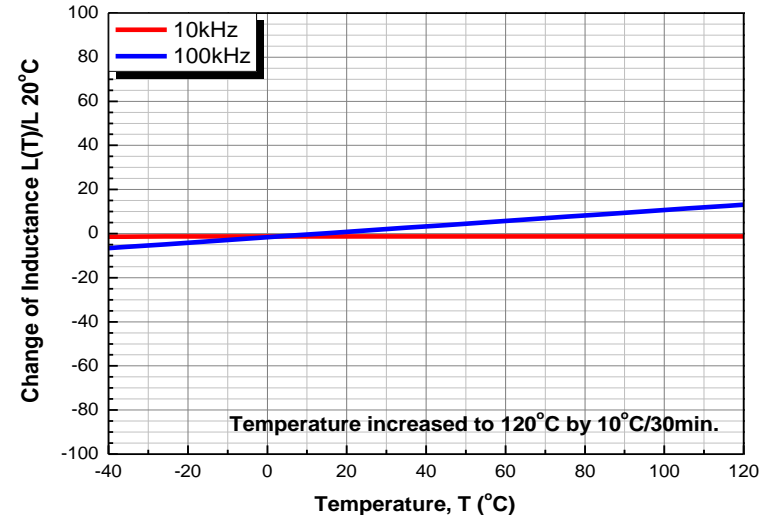
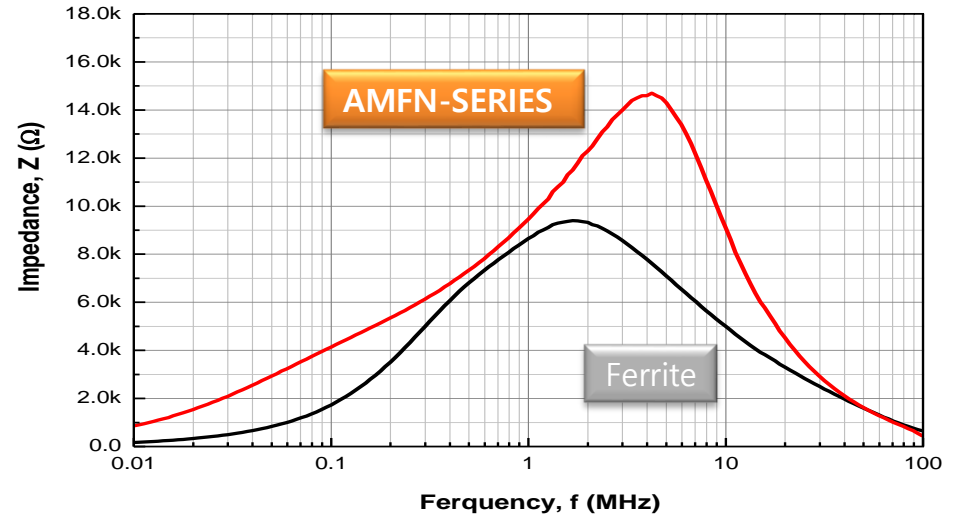



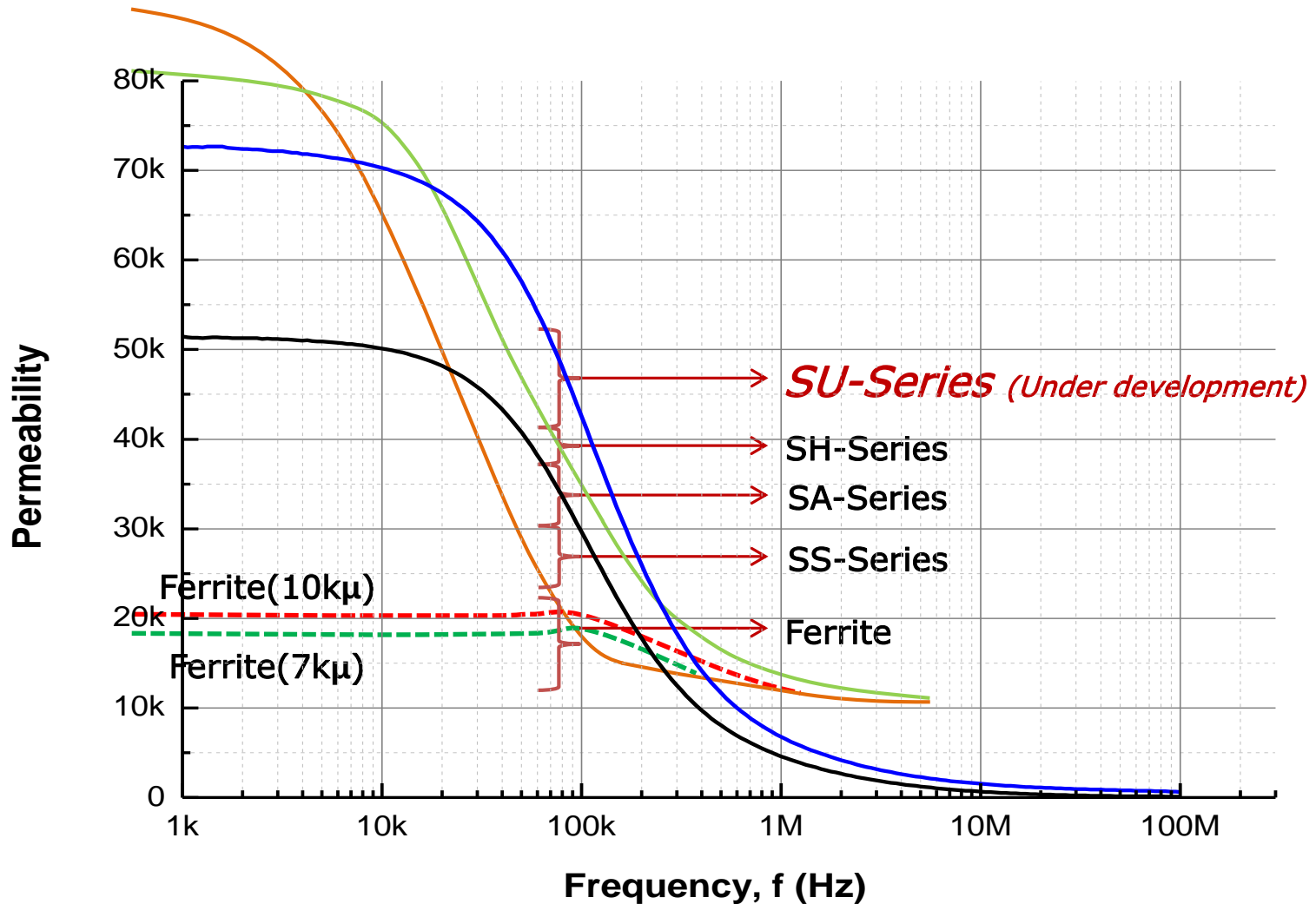



Permeability dependence on Freq. [**AMFN-Series** Vs Ferrite]



Standard product list

P/N (core), AMFN	Core Dimension [mm]			L _{Fe} [mm]	A _{Fe} [mm ²]	Mass [g]	Inductance, A _L (μH)		Cross product	
	O.D	I.D	H.T				10kHz	100kHz	H社	V社
161006SS	16	10	6	40.8	13.5	4.0	33.5	7.0		
161006SA	16	10	6	40.8	13.5	4.0	25.0	9.6		
161006SH	16	10	6	40.8	13.5	4.0	43.0	10.1		W403
181108SS	18	11	8	45.5	21.0	7.0	50.0	11.0		
201208SS	20	12.5	8	51.0	22.5	8.4	45.0	10.0		
201208SH	20	12.5	8	51.0	22.5	8.4	55.2	13.6		
201208SA	20	12.5	8	51.0	22.5	8.4	34.0	13.0		W409
252010SS	25	20	10	70.7	18.8	9.7	27.0	6.0		
252010SA	25	20	10	70.7	18.8	9.7	17.0	7.5		
252010SH	25	20	10	70.7	18.8	9.7	28.4	7.3		W523
251504SA	25	15	4	62.8	15.0	6.9	18.5	7.0		
251610SS	25	16	10	64.4	33.8	15.9	47.0	10.0		
251610SA	25	16	10	64.4	33.8	15.9	40.0	15.0		
251610SH	25	16	10	64.4	33.8	15.9	65.5	15.5		W380
302010SS	30	20	10	78.5	37.5	21.5	49.0	10.5		
302010SA	30	20	10	78.5	37.5	21.5	40.0	14.0		
302010SH	30	20	10	78.5	37.5	21.5	59.3	14.0		W423
302015SH	30	20	15	78.5	56.3	32.2	15.7	14.1		V129
312115SS	31	21	15	81.6	56.3	33.5	70.0	16.0		
312115SA	31	21	15	81.6	56.3	33.5	53.0	20.0		
312115SB	31	21	15	81.6	56.3	33.5	30.0	15.0		
372415SS	37	24	15	95.8	73.1	51.1	77.0	18.0		
372415SA	37	24	15	95.8	73.1	51.1	60.0	27.0	F3724E	
372820SS	36.5	28	20	101.3	63.8	47.1	64.0	14.5		
372820SA	36.5	28	20	101.3	63.8	47.1	48.0	18.5		
382612SA	38	26	12	100.5	54.0	39.6	32.0	15.0		
403215SH	40	32	15	113.0	45.0	37.1	47.2	11.1		W422
402515SH	40	25	15	102.1	84.4	62.9	101.0	23.1		W424
452520SS	45	25	20	109.9	150.0	120.3	130.0	30.0	F4424G	
504020SS	50	40	20	141.3	75.0	77.4	54.0	12.0		
504020SA	50	40	20	141.3	75.0	77.4	45.3	14.0		W516
543020SS	54	30	20	131.9	180.0	173.3	130.0	30.0		
604520SA	60	45	20	164.9	112.5	135.4	68.0	17.0	F6045G	
906020SV	90	60	20	235.5	225.0	386.8	81.0	25.1		W518
1008020SH	100	80	20	282.6	150.0	309.4	47.5	12.0	F10080G	

CM Core for EV & ESS

Circuit	Part no	Image
4kW Input EMI	AMFN 372415SA	
4.6kW OBC OPC	AMC-271525C	
4.6kW Input EMI	AMFN 574515SA	
Battery EMI	AMFN-102TR	
5kW Input CMC	AMFN 543020SS	
62kW Input CMC	AMFN906020SV	

Set-up EMI test center

※ Typical A_L tolerance : $\pm 30\%$

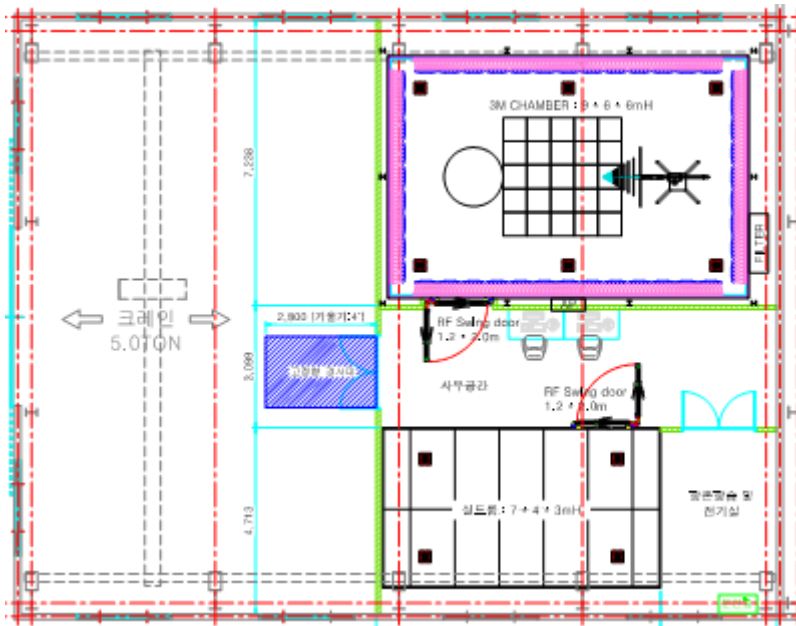

Contents	Remart
3M Anchoic Chamber System 9X6X6mh	RE/CE
EMI Test System	Antenna, Receiver

EMI Chamber for Certification

■ Radiated Emission

■ Conducted Emission

Example of case



[Toroid]









[Oval]



[Square]

The Case of each Application

Project	Product				
Drive Inverter					
OBC					
Power Pack					

2) Laminated core & Cut core

*High efficiency choke core
for high power application*

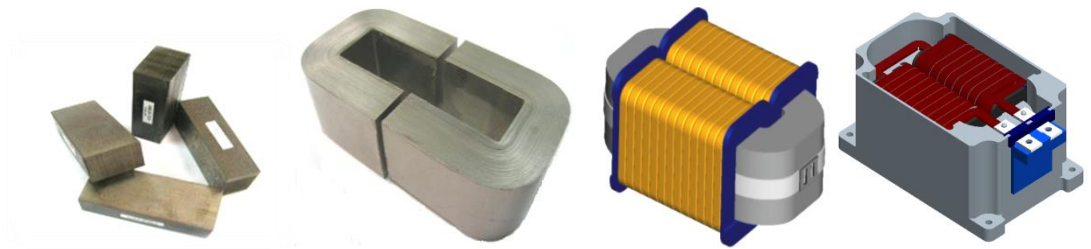

AMLB, AMCU-series



AMLB



AMCU

Application

- Transformers for welding machine, communication eq., etc.
- Inductors for solar inverter
- Inductors for boost/down converter of HEV, FCV, UPS, etc.



Features

- Low eddy current loss and hysteresis loss - resulting from 20~25 μ m
- High Saturation Flux Density (B_s , 1.56T)
- Stable temperature dependency
- Compact component size(30% reduction)
- High efficiency

Strength of Cut & Laminated Core

Cut Core

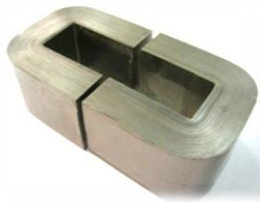

Laminated Core



- Unlimited size with Shape Laminated Core
- The lowest Core loss

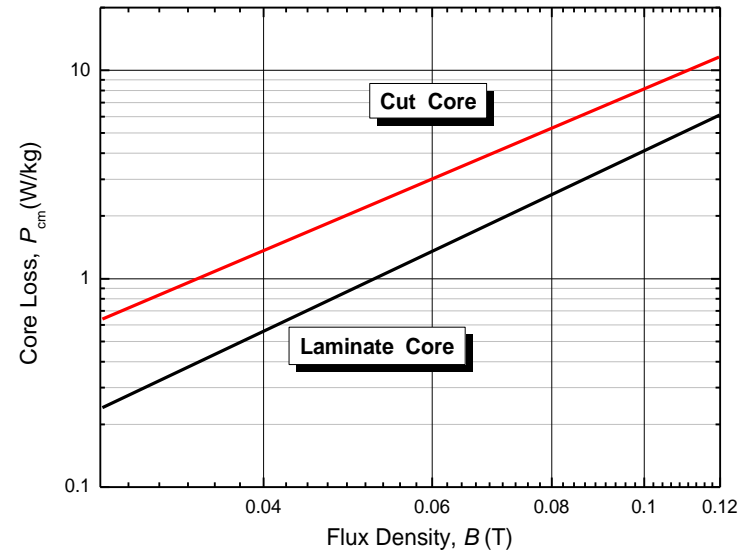
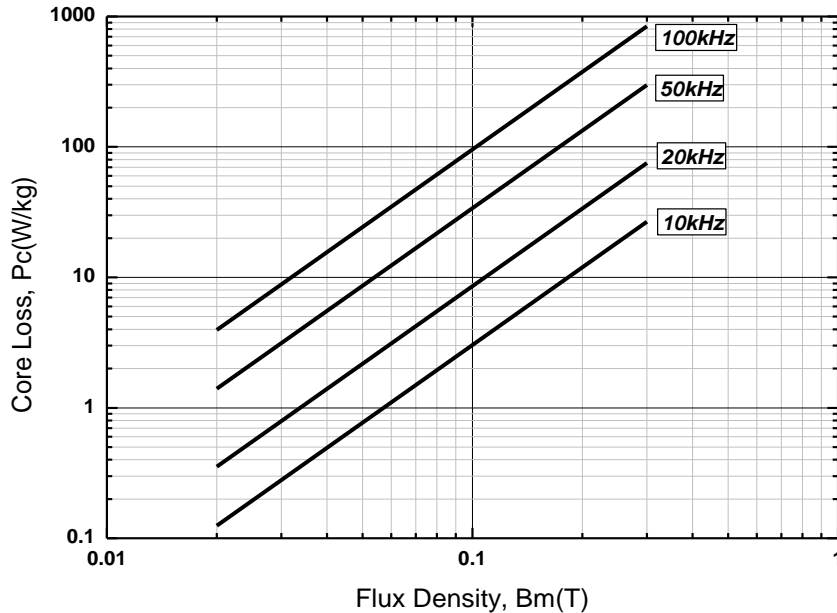

Core Loss, P_c (W/kg) = $6.5 \times f_{(kHz)}^{1.51} \times B_{ac}^{1.74}$
 when air gap is zero.

Core loss \approx Power loss

Cut Core 10W/kg \rightarrow Laminated Core 5W/kg@20kHz, 0.1T

Comparison data

Property		AMLB-Series	Super-E	Si-Steel	BK
B _s (T)		1.56	1.80	1.87	1.60
Core Loss [W/kg]	@ 0.1T, 20kHz z	7.8	20.9	51.6	18.2
L _{DC} / L ₀ (%) @ 100Oe		Dependent of gap size			
Size		Middle	Middle	Middle	Middle
Material		Fe-Si-B (Sheet)	Fe-Si(6.5%) (Sheet)	Fe-Si(3.5%) (Sheet)	Fe-Si(6.5%) (Powder)
Adaptive frequency (kHz)		18~80	~30	~13	~100

3) Powder Core

*High Performance and Cost Effective
PFC & DC Output Choke Core*

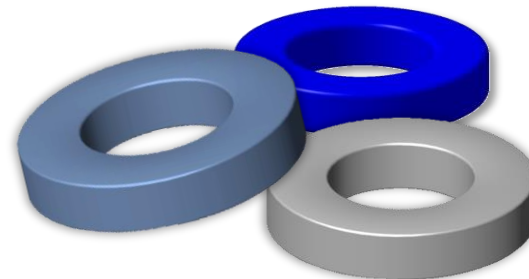

APH, APM, APK-series

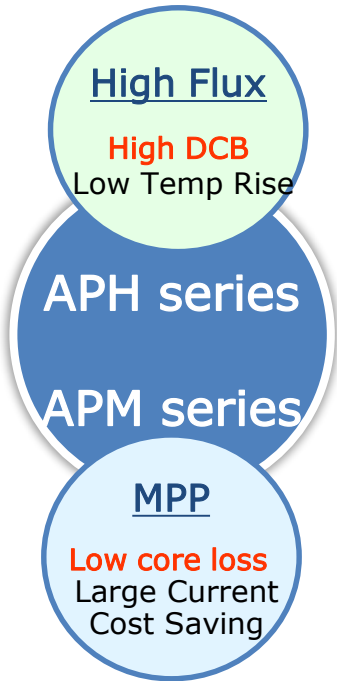

Application

- PFC chokes for PC EV, Solar
- PFC chokes for Server/5G telecom power supplies
- Output chokes for General Industrial power supplies

Features

- Reduce overall component cost than other solution
- Low ripple current
- High efficiency
- Compact in size(Save PCB size)
- Lowest temperature rise among the powder materials

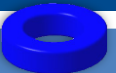

APH series	
Composition	Fe-Si-B
Permeability	60, 90 μ
Magnetic flux density	1.5T
Curie Temp.	\approx 395 $^{\circ}$ C

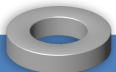

APM series	
Composition	Fe-Si-B-Nb-Cu
Permeability	26~125 μ
Magnetic flux density	1.2T
Curie Temp.	\approx 570 $^{\circ}$ C

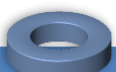

APK series	
Composition	Fe-Si
Permeability	26, 40, 60, 75, 90 μ
Size	\varnothing 13 ~ \varnothing 100
Magnetic flux density	1.6T
Curie Temp.	\approx 700 $^{\circ}$ C

Strength of APH & APM-series

- ▶ APH - Good DCB and Low core loss
- ▶ APM - The lowest core loss for High Efficiency

Inductance vs DC Bias Current

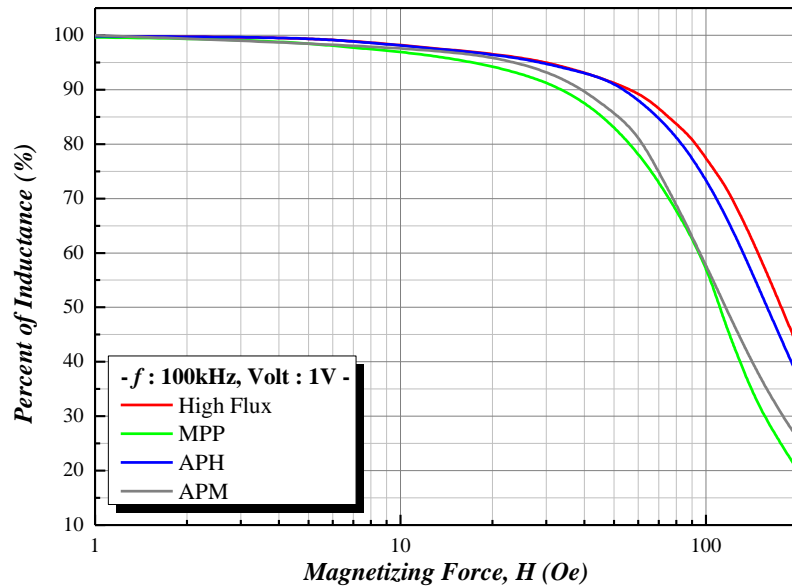

Core loss

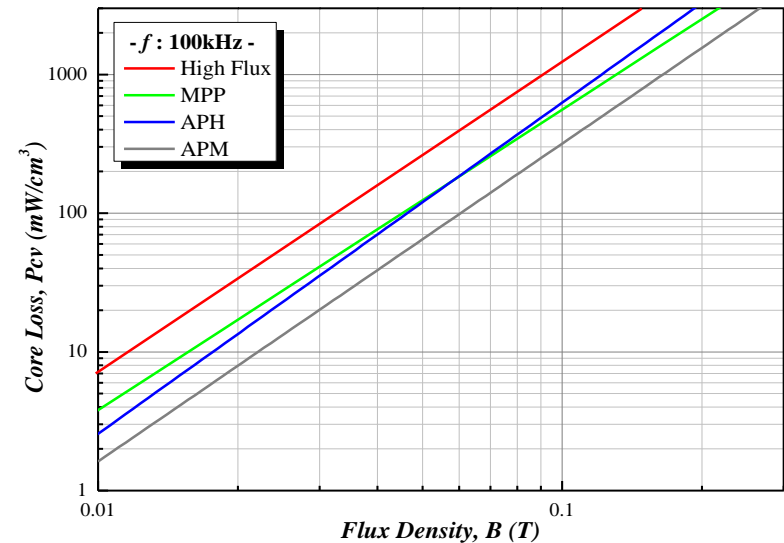

Note : The properties are typical value measured.(60μ)

Standard product list

Part no.	Size (Finished) (OD×ID×HT)	APH TM		APM TM				L _e (cm)	A _c (cm ²)	Vol (cm ³)
		A _L (nH/N ²)		A _L (nH/N ²)						
		60	90	26	60	90	125			
13P XX	13.5 × 7.0 × 5.5	27	40	12	27	40	56	3.12	0.11	0.36
17P XX	17.4 × 9.5 × 7.1	35	52	15	35	52	72	4.11	0.19	0.79
18P XX	18.0 × 9.0 × 7.1	43	64	19	43	64	89	4.14	0.23	0.96
20P XX	21.1×12.1× 7.1	32	49	14	32	49	68	5.09	0.23	1.15
23P XX	23.6 × 13.4 × 8.4	43	65	19	43	65	90	5.67	0.33	1.88
24P XX	24.3 × 13.8 × 9.7	51	76	22	51	76	105	5.88	0.39	2.28
27P XX	27.7×14.1 × 12.0	75	113	32	75	113	157	6.35	0.65	4.15
33P XX	33.8×19.3×11.6	61	-	28	61	92	127	8.15	0.67	5.48
36P XX	36.7×21.5×11.3	56	-	24	56	84	117	8.98	0.68	6.09
40P XX	40.7×23.3×15.4	81	122	35	81	122	168	9.84	1.07	10.55
46P XX	47.6×23.3 × 18.9	135	-	59	135	203	-	10.74	1.99	21.37
50P XX	51.7×30.9 × 14.4	73	-	32	73	-	-	12.73	1.25	15.93
57P XX	58.0×25.6 × 16.1	138	-	60	138	-	-	12.50	2.29	28.63

AP X XX P 60

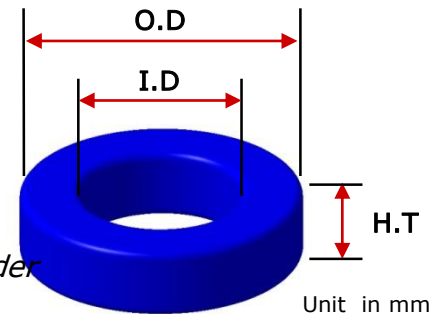
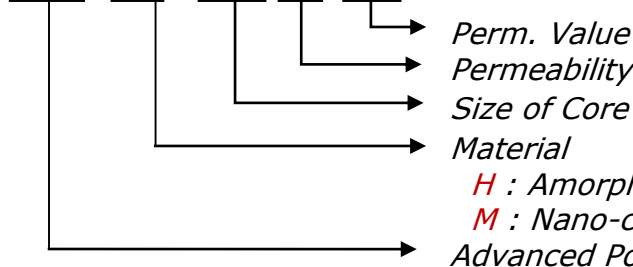

Comparison data

USA company (reference : catalog, 2017)





Property	APH AMORPHOUS	APM NANO- CRYSTALLINE	APK Fe-based metal	AMODUST Fe-based metal	High Flux	MPP	Sendust	Fe-Si
Saturation Flux Density Bs(Gauss)	15,000	12,000	16,000	11,000	15,000	7,500	10,000	16,000
Core Loss @100kHz, 0.1T (mW/cm ³)	600 ~700	300 ~400	1200 ~1300	500 ~ 600	1100 ~1200 (700 ~ 800)	600 ~700	700 ~800	1300 ~1500
Perm. vs DC Bias @100Oe	73%	53 %	70%	56%	78% (80%)	55%	45%	70%
Relative Cost	Medium	Med-Hi	Low	Lowest	High	Highest	Lowest	Low

* Note : The properties are typical value measured.(60μ)

() : Best in the field.





* Amodust is under development.

PFC Core for EV & ESS

	Circuit	Part no	Image
EV OBC	PFC 1 (3.7kW)	APM40P60	
	PFC 2 (4kW)	APH40P60	
	PFC 3 (4.6kW)	APH46P60	
ESS	PFC1 (5kW)	APH50P60	
	PFC2 (5kW)	APH57P60	

New type core – Shape core

Line-Up

Item		Features	
Shape Core	UIU	<ul style="list-style-type: none"> 2.4kW PFC Wiring area R shape Up grade DCB 	
	EEl	<ul style="list-style-type: none"> 2.4kW OPC High Properties Up grade DCB 	
	EQ	<ul style="list-style-type: none"> High Q High DCB 	
	FT Core	<ul style="list-style-type: none"> Squire shape for 1kW High performance 	
	Round block core (Cylinder)	<ul style="list-style-type: none"> Various Size & properties Good assemble 	

Features

- High permeability
- High Shaping Strength
- High Technology
- Hybrid powder

4) Current Transformer

*For electronic watt meters
and charging application*

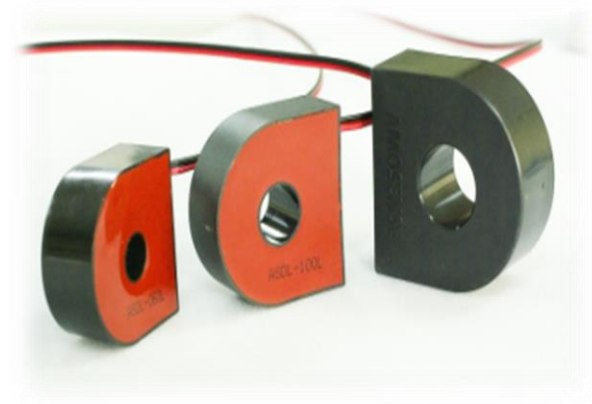

AST, ASM, ASD series

AST-series

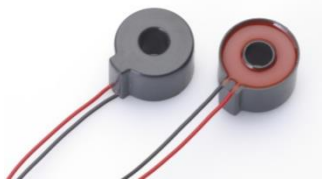

Application

- Excellent accuracy power sensor and instruments
- 0.2~1.0 class smart meters

Features

- Very small phase and amplitude error
- Easily compensable phase error
- Very low losses
- Low temperature dependence

ASD-series ASM-series

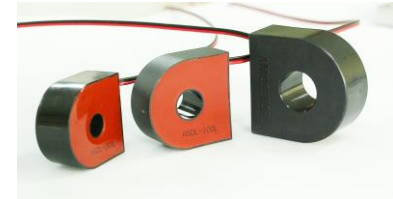

Application

- Precise DC immune electronic energy meters conforming to IEC 62053-21, -23
- Accurate measurement under DC components

Features

- Excellent linearity and precision
- Steady phase shift and No saturation in DC factor
- Stability from the external magnetic field
- Negligible small amplitude error & Very low losses
- Possible to adopt the permanent magnetic immunity

Comparison data

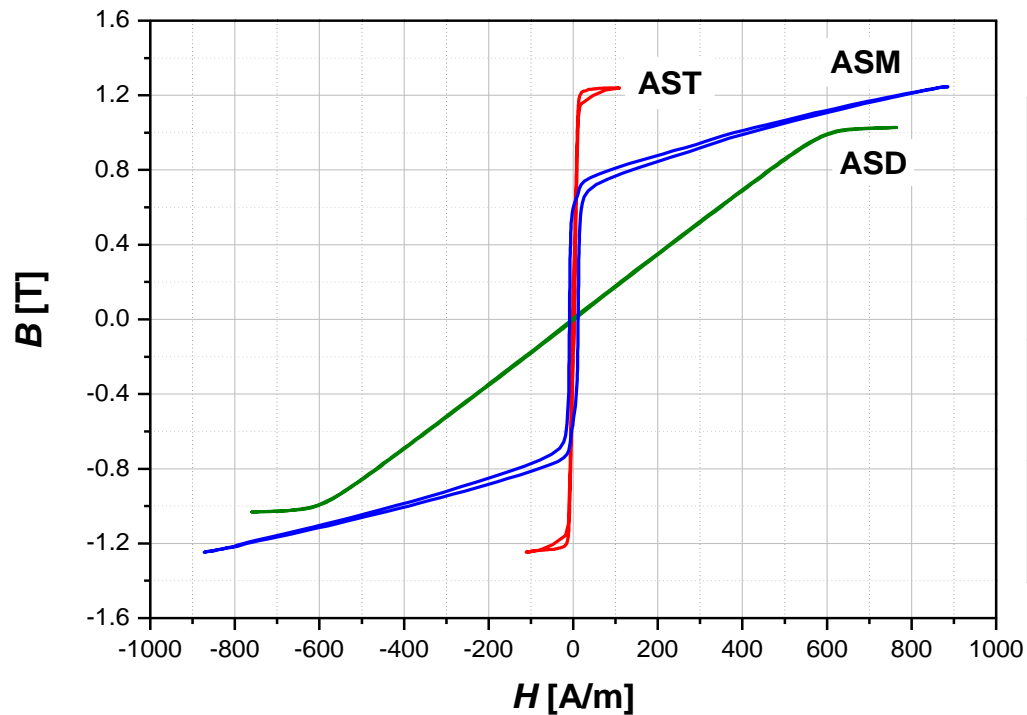

Series	Bs[T]	Perm[μ]	DC-immune	Remark
AST	~1.2	~160k	No	IEC62053-22 ANSI C12.xx
ASM	~1.5	30k~40k	Yes	IEC62053-21, IEC62053-23
ASD	~1.0	1k~3k	Yes	IEC62053-21, IEC62053-23

Standard product list

Part number (P/N)	Primary current range		Turns ratio 1:□	Errors		Characteristics			Dimensions	
	I_N (A _{rms})	$I_{DC,MAX}$ (A _{op})		Phase Φ (°)	Amplitude F (%)	L (H)	R _{cu} (Ω)	R _B (Ω)	Φ (mm)	Width x height (mm x mm)
AST-005P/L	5	-	2500	0.30	0.02	183	152	150	6	24.5 x 11.1
AST-005PA/LA	5	-	2500	0.38	0.02	183	236	150	7.7	23.2 x 10.8
AST-006P	6	-	2000	0.25	0.02	156	114	30	6.3	24.5 x 11.5
AST-040P/L	40	-	2500	0.17	0.01	183	152	18.75	6	24.5 x 11.1
AST-040PA/LA	40	-	2500	0.25	0.01	183	236	18.75	7.7	23.2 x 10.8
AST-060P	60	-	2500	0.09	0.01	143	63	12.5	7.7	31.1 x 15.3
AST-080P/L	80	-	2500	0.14	0.03	226	160	9.375	8.9	26.1 x 17.1
AST-120L	120	-	2500	0.10	0.04	180	68	6.25	12.2	39.0 x 17.6
ASM-040L	40	40	2500	0.18	0.02	149	147	18.75	7	26.3 x 17.3
ASM-060L	60	60	2500	0.22	0.02	156	160	12.5	8.5	26.0 x 17.5
ASM-120L	120	120	2500	0.17	0.02	133	103	6.25	14.5	38.4 x 15.0

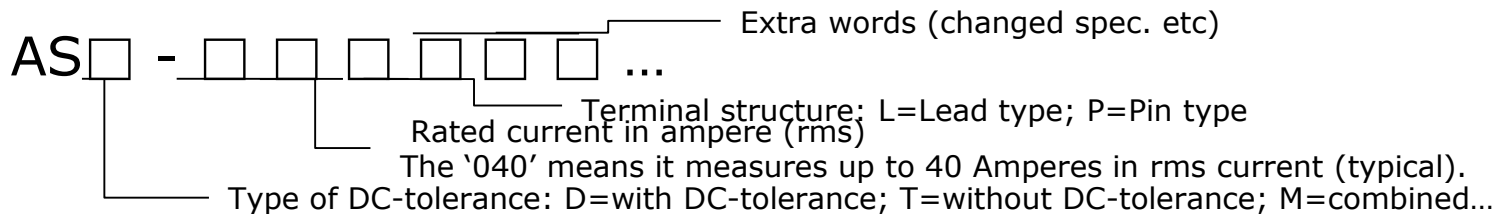

Comparison data

Item	Current transformer	Shunt resistance	Hall effect sensor	Rogowski coil
Cost	Low or Medium	Low	High	Low or Medium
Power Consumption	Low	High	Medium	Low
Electric insulation	Good	Bad	Good	Good
Accuracy	0.1~1%	0.5~5%	0.1~1%	1~2%
Output variation with temperature	Small	Medium	Large	Small
Saturation & Hysteresis problem	Yes	No	Yes	No
Power Supply	Unnecessary	Unnecessary (Adds amplifier)	Unnecessary	unnecessary (Adds integrator)

Cross reference table

Type	Primary Current Range	AMOGREENTECH	VAC
With DC-tolerance	20A	ASD-020L	E4622-X101
	40A	ASD-040L	E4623-X101
	60A	ASD-060L	E4624-X101
	100A	ASD-100L / ASM-100L	E4626-X101
	120A	ASD-120L / ASM-120L	E4627-X101
Without DC-tolerance	6A	AST-005PS	E4658-X043
		AST-005P	E4622-X501 / E4622-X503
	40A	AST-040P/L	E4623-X002
	60A, 80A	AST-060P AST-080P/L	E4624-X502 / E4622-X002
	120A	AST-120L	E4626-X002

Clamp CT



Part no.	Input current [A]	Output current [mA]	Turns ratio [:1, Ts]	Burden resistance	Error range [%]
ASLC-060L	0~50	0~16.67	2000 3000 4000 5000	20Ω	±0.5~1.0
ASLC-120L	0~100	0~33.33			
ASLC-150L	150	5000	30	1VA	1.0

Application

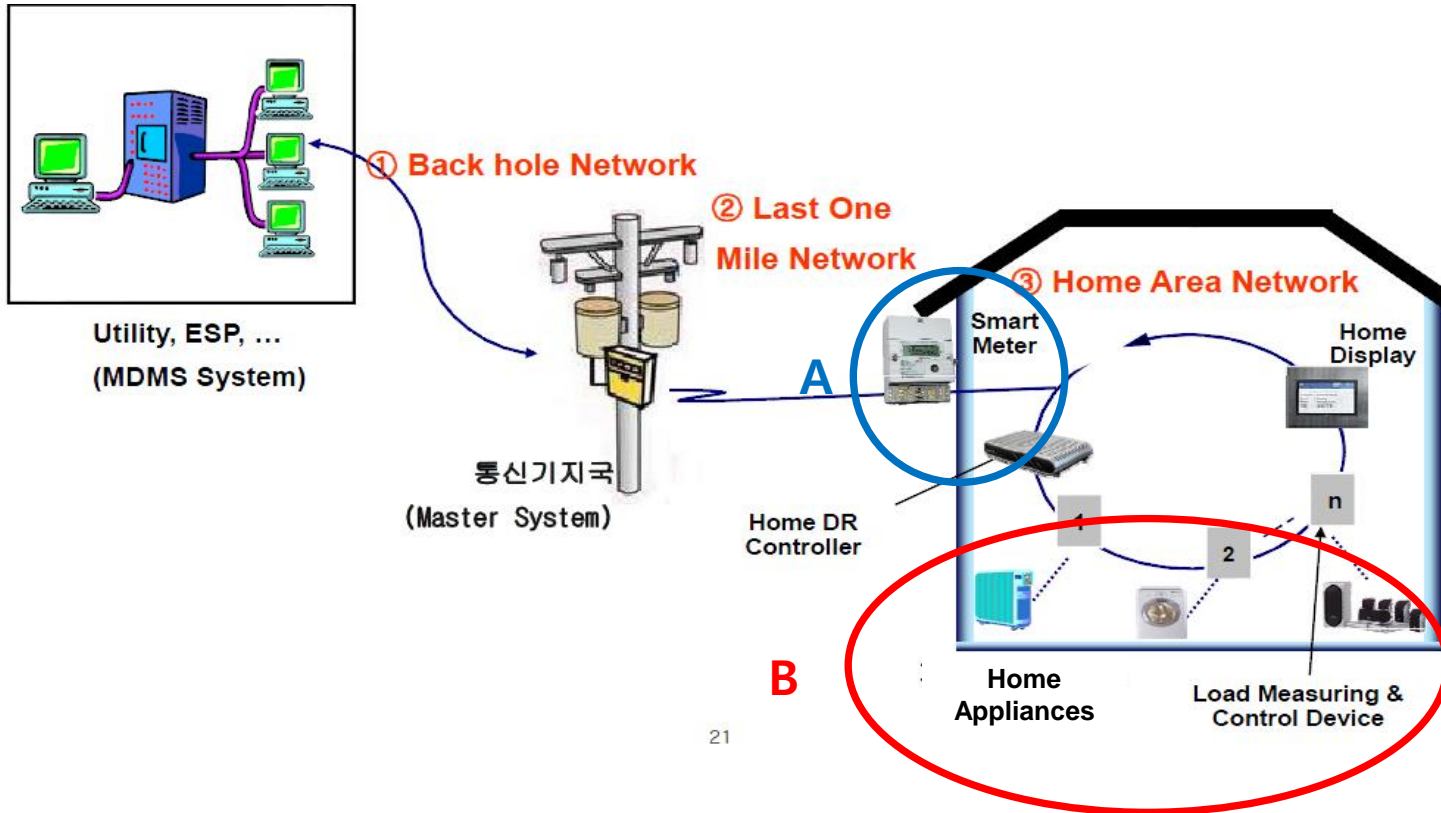

A : Smart Meter – CT with DC-Tolerance or without DC-Tolerance (AST, ASM-Series)

B : Household Appliances – CT without DC-Tolerance (AST-Series)

(air conditioner, refrigerator, washing machine, electric heater, etc)

Application

3.3kW On board Charger

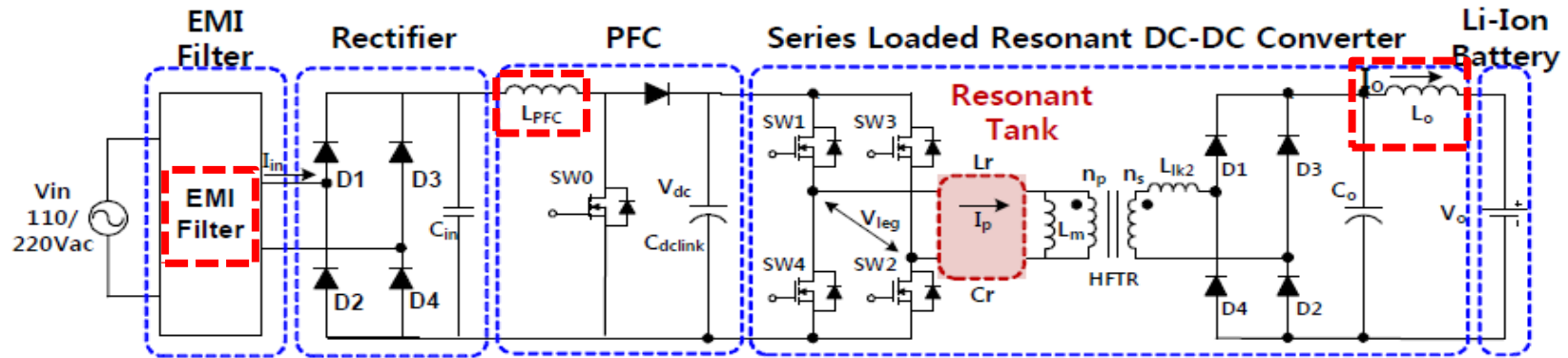

PFC & Output Choke : APH-Series

EMI filter : AMFN-Series

Ex) System Parameters

Parameter	Value [Unit]
Rate Power	3.3 [kW] @220V, 1.6 [kW] @110V
Input Voltage	100-277 (+/-10%) [V_{rms}]
Output Voltage	200-450 (+/-2%) [V_{dc}]
Output Current	10 (+/-5%) [A]
Ripple Voltage	<25 [V_{pp}]
Ripple Current	<10% from $I_{nominal}$
Resonant Frequency	71 [kHz] (Q-factor = 1.58)
Switching Frequency	80-130kHz



Application

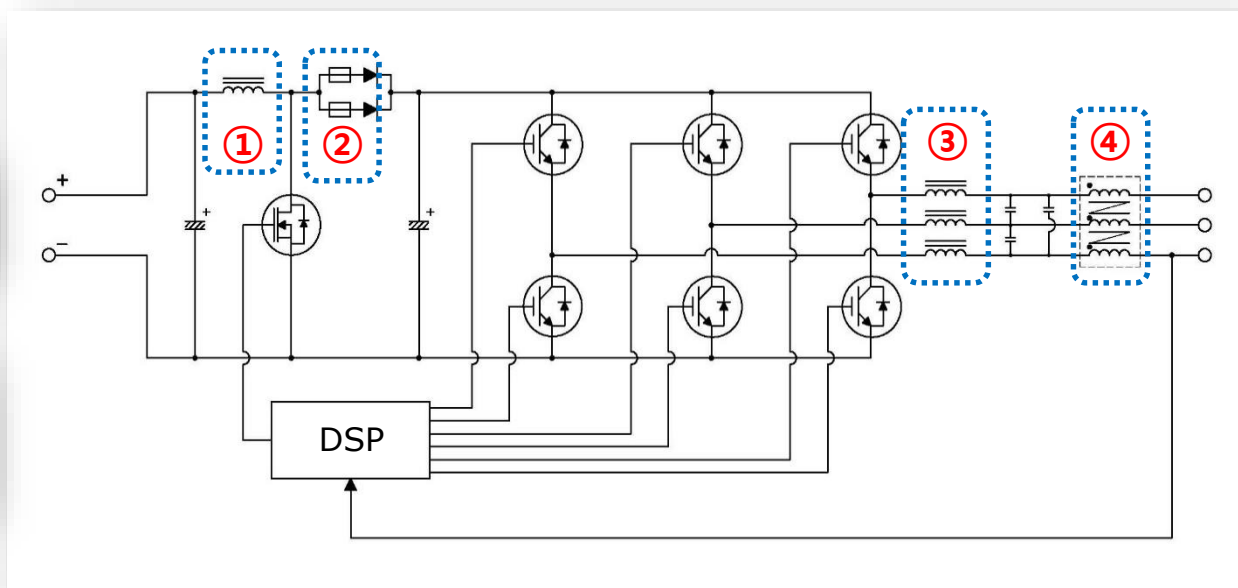

HVAC

No.	Choke	Function of choke	Required properties	AMOGREENTECH Model-series
①	Normal mode choke	Voltage Boosting	Low core loss	APH, APM, AMLB-series
②	Spike killer choke	Semiconductor noise filtering	High permeability	AMB-series
③	Normal mode choke	DC-AC inverting	Low core loss	APH, APM, AMLB-series
④	Common mode choke	EMI noise filtering	High permeability	AMFN-series

For **Customer**

Thank you