

# LSUM 016R8L 0058F EA

The Ultracapacitor, also known as double-layer capacitor, stores energy by means of a static charge as opposed to a battery, which uses an electrochemical reaction.

The Ultracapacitor is used for energy storage applications which undergo very frequent charge and discharge cycles at high current and short duration. Its life can be as high as one million cycles. It features a wide operating temperature range, from - 40°C to 65°C, making it an ideal energy storage device for extreme environments.

It can be applied in wind power, hybrid systems, industrial automation, power backup and stabilization. Imagination is its only boundary.



## PERFORMANCE SPECIFICATIONS

Rated Voltage(Nominal)	16.8 V
Serge Voltage	18.0 V
Max. Series Voltage	750 V
Capacitance	58 F
Capacitance Tolerance	- 0% / + 20%
Max. ESR DC	22.0 mΩ
Typical ESR DC	21.0 mΩ
Total Energy	2.3 Wh
Max. Current <sup>1</sup>	210 A
Leakage Current <sup>2</sup>	< 11 mA
Rated voltage of Cells	2.8 V
Capacitance of Cells	350 F
Number of Cells	6 Series

<sup>1</sup> The stated maximum peak current should not be used in normal operation and is only provided as a reference value.

<sup>2</sup> The module leakage current is based on the calculated value. It may change depending on the cell balancing configuration.

## LIFE INFORMATION

Endurance Life (65 °C)	1500hr
Capacitance Change <sup>3</sup>	< 20%
ESR DC Change <sup>4</sup>	< 100%
Projected Life (25 °C)	10 Years
Capacitance Change <sup>3</sup>	< 20%
ESR DC Change <sup>4</sup>	< 100%
Projected Cycle Life (25 °C) <sup>5</sup>	500,000 Cycles
Capacitance Change <sup>3</sup>	< 20%
ESR DC Change <sup>4</sup>	< 100%
Shelf Life (25 °C) <sup>6</sup>	4 Years

<sup>3</sup> Decrease from minimum initial value.

<sup>4</sup> Increase from maximum initial value.

<sup>5</sup> Cycle Life may vary for different working conditions. (e.g. voltage or temperature)

<sup>6</sup> Stored uncharged state under appropriate storage conditions.

## THERMAL SPECIFICATIONS

Max. Continuous Current ΔT=15 °C <sup>7</sup>	12 A
Max. Continuous Current ΔT=40 °C <sup>7</sup>	20 A
Thermal Resistance (°C/W) <sup>8</sup>	4.73 °C/W

<sup>7</sup>Initial state value.

<sup>8</sup>The specification is calculated under limited conditions.

## SAFETY INFORMATION

Short Circuit Current <sup>9</sup>	760 A
Isolation Voltage (DC, Terminal – Case, 60 sec)	5.6 kV
Certification	RoHS, REACH

<sup>9</sup>Calculated value. Do not use as an operating current.

## MONITORING INFORMATION

Temperature Sensor	-
Communication Interface	-
Connector	-
Cell Voltage Monitoring	-
Cell Balancing	Active, Passive (option)

**MECHANICAL SPECIFICATIONS**

Length	245.0 ± 1.0 mm
Width	47.0 ± 1.0 mm
Height	76.6 ± 1.0 mm
Weight	Max. 0.7 kg

**PHYSICAL SPECIFICATIONS**

Power Terminals	M5 Thread
Recommended Torque (Terminal)	4Nm
Vibration & Shock Protection <sup>10</sup>	IEC60068-2-27,29 / IEC60068-2-6
Environment Protection <sup>10</sup>	-

<sup>10</sup>The specifications are for tests with limited conditions and may differ under actual conditions.

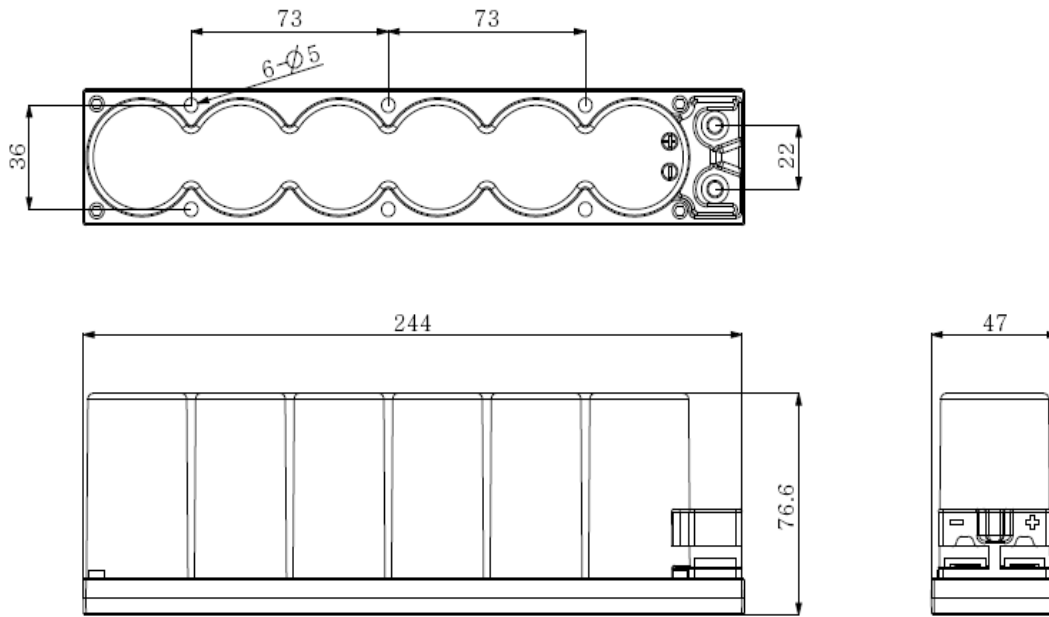

**Markings**

- Positive / Negative terminal
- Serial number
- Part number

**Accessories (Not Included)**

Notice : Product dimensions and specifications may change without notice. Please contact LS Materials for any technical specifications.