



# SILICON CARBIDE FOR EV FAST CHARGING

SemiQ's broad spectrum of Silicon Carbide (SiC) diodes, modules and MOSFETs meet the demands of high efficiency EV Fast Charging designs with best-in-class reliability, quality, and performance. Our 1200V diodes in Modules and Discrete packages in a range of voltages and currents give the ultimate in efficiency gains for DC Fast Charging systems to 300kW and beyond.

## Benefits of SemiQ SiC in EV Fast Charging

- ⬢ High Efficiency
- ⬢ Reduced Operational Temperatures
- ⬢ Long-term Reliability
- ⬢ Reduced Design Complexity versus Silicon
- ⬢ Over 20 Million Hours of HTRB/H3TRB Testing
- ⬢ Uni-directional and Bi-directional Conversion

## Typical EV Charging Schematic

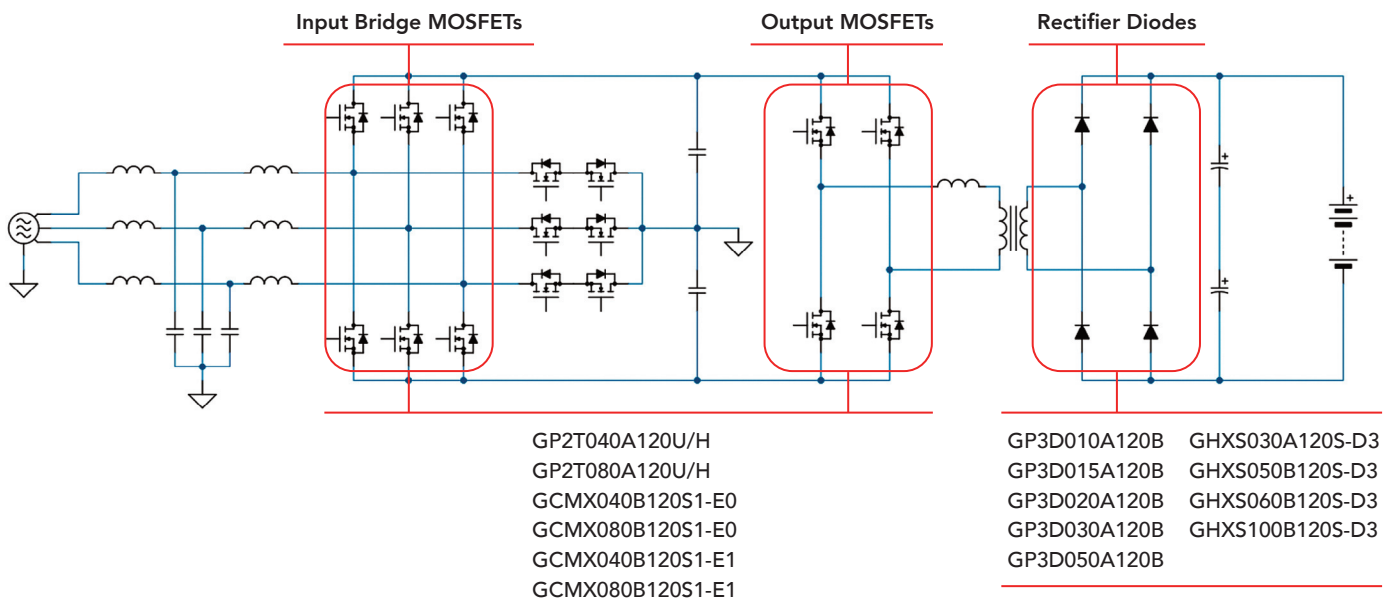

## SemiQ SiC 1200V and 1700V Product Family

SemiQ Part Number	Voltage	Current Rating Per Diode	Package	Description
GHXS030A120S-D3	1200V	30	SOT-227	Dual SiC Diodes
GHXS050B120S-D3	1200V	50	SOT-227	Dual SiC Diodes
GHXS060B120S-D3	1200V	60	SOT-227	Dual SiC Diodes
GHXS100B120S-D3	1200V	100	SOT-227	Dual SiC Diodes
GHXS050B170S-D3	1700V	50	SOT-227	Dual SiC Diodes
GHXS100B170S-D3	1700V	100	SOT-227	Dual SiC Diodes
GP3D010A120A	1200V	10	TO-220-2L	SiC Schottky Diode
GP3D010A120B	1200V	10	TO-247-2L	SiC Schottky Diode
GP3D015A120A	1200V	15	TO-220-2L	SiC Schottky Diode
GP3D015A120B	1200V	15	TO-247-2L	SiC Schottky Diode
GP3D020A120B	1200V	20	TO-247-2L	SiC Schottky Diode
GP3D020A120U	1200V	2X10	TO-247-3L	SiC Schottky Diode
GP3D030A120B	1200V	30	TO-247-2L	SiC Schottky Diode
GP3D030A120U	1200V	2X15	TO-247-3L	SiC Schottky Diode
GP3D040A120U	1200V	2X20	TO-247-3L	SiC Schottky Diode
GP3D050A120B	1200V	50	TO-247-2L	SiC Schottky Diode
GP3D060A120U	1200V	2X30	TO-247-3L	SiC Schottky Diode
GP3D005A170B	1700V	5	TO-247-2L	SiC Schottky Diode
GP3D010A170B	1700V	10	TO-247-2L	SiC Schottky Diode
GP3D020A170B	1700V	20	TO-247-2L	SiC Schottky Diode
GP3D050A170B	1700V	50	TO-247-2L	SiC Schottky Diode

SemiQ Part Number	Voltage	RDS-On mΩ	Package	Description
GCMX080B120S1-E0	1200V	80	SOT-227	SiC MOSFET
GCMX040B120S1-E0	1200V	40	SOT-227	SiC MOSFET
GCMS080B120S1-E1	1200V	80	SOT-227	SiC MOSFET w/SiC SBD
GCMS040B120S1-E1	1200V	40	SOT-227	SiC MOSFET w/SiC SBD
GP2T080A120U	1200V	80	TO-247-3L	SiC MOSFET
GP2T080A120H	1200V	80	TO-247-4L	SiC MOSFET
GP2T040A120U	1200V	40	TO-247-3L	SiC MOSFET
GP2T040A120H	1200V	40	TO-247-4L	SiC MOSFET

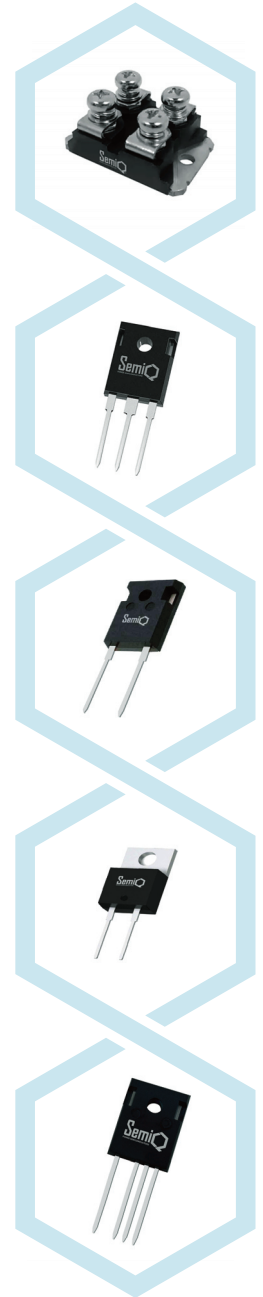

SemiQ is a designer and manufacturer of Silicon Carbide power semiconductors, focused on delivering industry-leading performance of the highest quality and reliability with a fully redundant supply chain. We have a broad product offering fitting many end applications and provide global support from design through production.

SemiQ Incorporated | 20692 Prism Place, Lake Forest, California 92630 | sales@SemiQ.com

Distribution  
Partner



800.348.5580  
630.208.2200



rellpower.com  
rellpower@rell.com