



# OpenIMU335RI

Triple-Redundant 1.3°/h Open-Source IMU with CAN Output



The ACEINNA OpenIMU335RI is an easy-to-use high-performance 9-DOF open inertial platform packaged in a rugged sealed over-molded plastic housing. The OpenIMU335RI includes triple-redundant 3-Axis MEMS accelerometers and rate gyros which are fully calibrated over the operating temperature range. A 3-axis magnetic sensor is also available as an option. The processing power is provided by a 168MHz ARM M4 CPU with a Floating Point Unit. The OpenIMU335RI runs the OpenIMU open-source stack that includes an optimized 16-state Kalman Filter for Attitude and GPS-Aided Position-Velocity-Time (PVT) measurement. A free tool-chain based on VS Code supports PC, MAC, and Ubuntu.



# OpenIMU335RI

Triple-Redundant 1.3°/h Open-Source IMU with CAN Output

The ACEINNA OpenIMU335RI is designed for use in 12 V and 24 V vehicle platforms. The plastic over-molded sealed packaging meets the challenging performance, reliability and cost requirements of the automotive, construction and agriculture vehicle markets.

## Applications

- Autonomous Vehicles
- Self-Driving Taxis / Delivery Vehicles
- Construction Vehicles
  - Boom, Bucket and Cab Attitude
- Agriculture Vehicles and Implements
- Forklifts
- Robotics Control / Feedback
- Antenna / Camera Gimbaling and Stabilization



## Features

- 0.1° accuracy over temperature and angle
- Precision 3-axis MEMS Accelerometer
- Low-Drift 3-axis MEMS angular rate sensor
- Triple-redundant architecture with fault detection
- 3-axis AMR Magnetometer (Optional)
- CAN 2.0 and RS232 Interfaces
- 168 MHz ARM M4 processor
- Open Source Tool Chain / Algorithms (VG/AHRS/INS)
- Built in 16-State Open Source EKF
- Open Community & Support
- Wide Temp Range, -40C to +85C
- Wide Supply Voltage Range, 9 V – 32 V
- IP67 Ampseal Connector
- High Reliability, MTBF > 50k hours

This product has been developed exclusively for commercial applications. It has not been tested for, and makes no representation or warranty as to conformance with, any military specifications or its suitability for any military application or end-use. Additionally, any use of this product for nuclear, chemical or biological weapons, or weapons research, or for any use in missiles, rockets, and/or UAV's of 300km or greater range, or any other activity prohibited by the Export Administration Regulations, is expressly prohibited without the written consent and without obtaining appropriate US export license(s) when required by US law. Diversion contrary to U.S. law is prohibited. Specifications are subject to change without notice.



# OpenIMU335RI

Triple-Redundant 1.3°/h Open-Source IMU with CAN Output

## Performance Specification

Ta = 25°C, VDC = 12 V, unless otherwise stated

Angular Rate	MIN	TYP <sup>2</sup>	MAX
Range (°/s)	-400		+400
Bias Instability (°/hr) <sup>1</sup>		1.3	
Bias Stability over Temp (°/s)		0.1	
Scale Factor Accuracy (%FSR)		0.1	
Cross-Axis Error (%FSR)		0.1	
Non-linearity Error (%FSR)		0.1	
Angle Random Walk (°/√hr) <sup>1</sup>		0.1	
Configurable Bandwidth (Hz)	5		50
Acceleration	MIN	TYP <sup>2</sup>	MAX
Range (g)	-8		+8
Bias Instability (μg) <sup>1</sup>		20	
Bias Stability over Temp (mg)		1.3	
Scale Factor Accuracy (%FSR)		0.1	
Cross-Axis Error (%FSR)		0.1	
Linearity Error (%FSR)		0.1	
VRW (m/s/√hr) <sup>1</sup>		0.02	
Configurable Bandwidth (Hz)	2		50
Pitch / Roll (with VG EKF)	MIN	TYP <sup>2</sup>	MAX
Pitch Angle Range (°)	-70		+70
Roll Angle Range (°)	-180		+180
Angle Accuracy over Temp (°)		0.1	
Angle Accuracy over Angle Range (°)		0.1	
Magnetic Field (optional <sup>3</sup> )	MIN	TYP <sup>2</sup>	MAX
Range (mGauss)	-8000		+8000
Resolution (mGauss)		0.3	
Noise (mGauss/√Hz)		0.25	
Bandwidth (Hz)		5	

Note 1: Allan variance curve, constant temperature

Note 2: Typical values are 1-sigma values unless otherwise noted

Note 3: Contact Factory for availability of magnetic sensor

## Electrical Specifications

Characteristic	Specification
Input voltage	9 – 32 V
Over voltage	36 V
Reverse voltage	-36 V
Current	< 100 mA
Power	< 400 mW
Reset response	Automatic after voltage dropout
Start-up time	<2 seconds
Max Output Data Rate	100 / 200 Hz (CAN / Serial)
CAN Baud rate	250k – 1M
RS232 Baud Rate	38400 – 230400

## Physical Specifications

Characteristic	Specification
Dimensions	65 x 66 x 27 mm
Weight	< 75 g
Interface Connector	Ampseal 16 – 6 Position IP67
Mating Connector	TE Connectivity 776531-1

## Environmental Specifications

Characteristic	Specification
Operating Temperature	-40 – 85 °C
Storage Temperature	-40 – 85 °C
Ingress Protection	IP67, IP69K

## Qualification Plan Summary (Not inclusive of all tests)

Electrical Loads	DUTs	Op Mode <sup>3</sup>	Function Class <sup>3</sup>	Summary
Over Voltage (V)	3	3.2	A	SAE J 1455 4.13.1: 36 V, 60 minutes
Reverse Voltage (V)	3	1.1	C	SAE J 1455 4.13.1: -36 V, 5 minutes
Short Circuit	3	3.2	C	ISO 16750-2 4.10.2: Signal circuits
Starting Profile	3	3.2	A	ISO 16750-2 4.6.3: 10 pulses, 24 V System, Level II
Load dump	3	3.2	A	5 pulses, 56V, 90 s pulse rate; 95 pulses 56V 120 s pulse rate
Reset Behavior at Voltage Drop	3	3.2	B	ISO 16750-2 4.6.2
Mechanical Loads				
Vibration Swept Sine	4	3.2	A	5 – 500 Hz; <10 Hz Displacement = ± 12 mm; >10 Hz = 5 g Pk
Vibration Random	4	3.2	C	5 – 2000 Hz; 15.35 g RMS, 48 hrs/axis
Mechanical Bump	4	3.2	C	100 bumps x 3 axis/DUT (600 Total/DUT) 400m/s <sup>2</sup> , ½ sine, 6 ms pulse
Mechanical Shock	4	3.2	C	3 Shocks x 3 axis x 2 directions (18 total) 981m/s <sup>2</sup> , ½ sine, 11 ms pulse
Mechanical Drop	2	1.1	C	1 m to steel plate, 1 drop x 3 axis x 2 directions (6 total)

Note 3: ISO 16750-1 Operation Mode and Function Class definition

### EMC Specifications

Characteristic	Standard	Test Level / Frequency
ESD direct contact discharge	ISO 10605	8 kV - Function Class A, Reference Limits IV
ESD air discharge	ISO 10605	15 kV - Function Class A, Reference Limits IV
Radiated Immunity Stripline	ISO 11452-5	200 V/m, 0.5 – 250 MHz
Radiated Immunity ALSE	ISO 11452-2	125 V/m, 200 – 1000 MHz 40 V/m, 1 GHz – 2 GHz 15 V/m, 2 GHz – 2.4 GHz 10 V/m, 2.4 GHz – 2.7 GHz
EMC Conducted Transmission	ISO 16750-2; ISO 7637	24 V Parameters, Pulse 1, 2a, 2b, 3a, 3b, 4, 5b

### Development Kit

- OpenIMU335RI EVK
- Special Housing with JTAG connection for development / debugging
- ST-Link debugger for in-system development of application code
- Fixture and Interface JTAG board
- Development Cable with Ampseal 16-6 Position to Dual DB9
  - CAN 2.0 Connection DB9
  - RS232 Connection DB9
  - Flying Lead for power connection

### Open Navigation Platform

Embedded navigation applications quickly developed on PC, MAC, and Ubuntu and deployed to run on OpenIMU hardware.

- Code / Compile / Debug
- Simulate / Analyze

Aceinna Navigation Studio developer tools and GUI are found on our developer site: [developers.aceinna.com](http://developers.aceinna.com)

Full manual, API and Algorithm documentation are found at: [openimu.readthedocs.io](http://openimu.readthedocs.io)

IDE and Compilation tools, download VS Code and Add Aceinna Extension: [code.visualstudio.com](http://code.visualstudio.com)

### Ready to Use Open Source Algorithms

- Calibrated IMU, 3D Acceleration, 3D Rate, 3D Mag
- VG / AHRS, Dynamic Roll, Pitch and Heading
- INS, Position, Velocity, Attitude and Heading

### Development System Requirements

- PC or MAC
- USB Port (2.0)
- Internet Connection

### Dimensioned Drawing

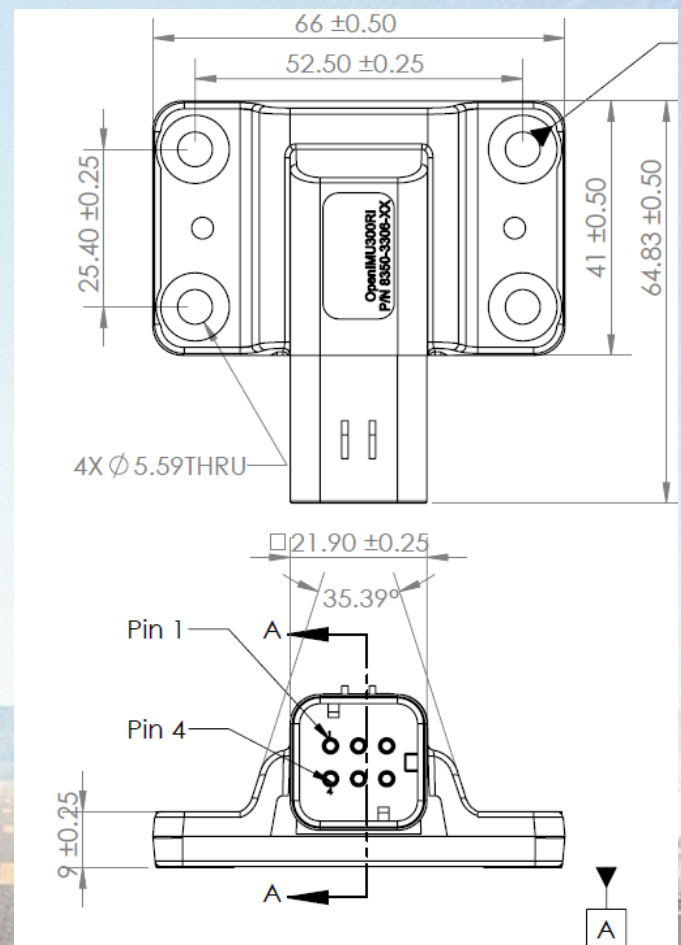

Part Ordering Information	
Rugged High-Performance OpenIMU Platform	
OpenIMU335RI	Industrial Grade: 6 DOF IMU, FSR = 400dps / $\pm 8g$
OpenIMU335RI EVK	Developer Kit with OpenIMU300RI with JTAG, STLink/v2 and developer cable
MTLT305 Cable	Mating Connector with flying leads