

ELECTRONICS COMPONENTS

CURRENT SENSORS



Contents

Group network map	1
Outline / Applications / Features / Applications map / Guide map	2
Circuit system / Application notes / Part numbering system	7
Important Notice	10
According to UL508 standard and CSA C22.2 No.14 standard	11
Data sheet F-Series, L-Series, S-Series	19

Group network map

Group Network - Overseas

○: Sales □: Factory ▲: R&D

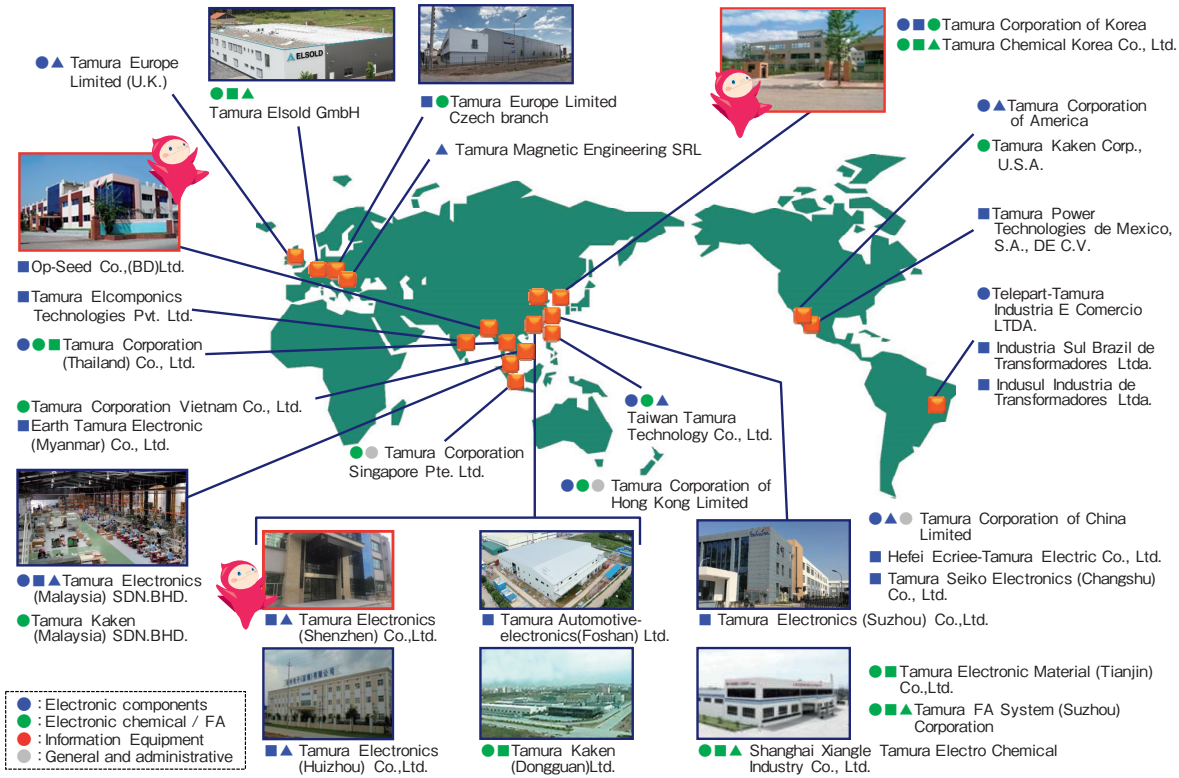
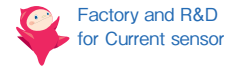

Group Network - Japan

○: Sales □: Factory ▲: R&D

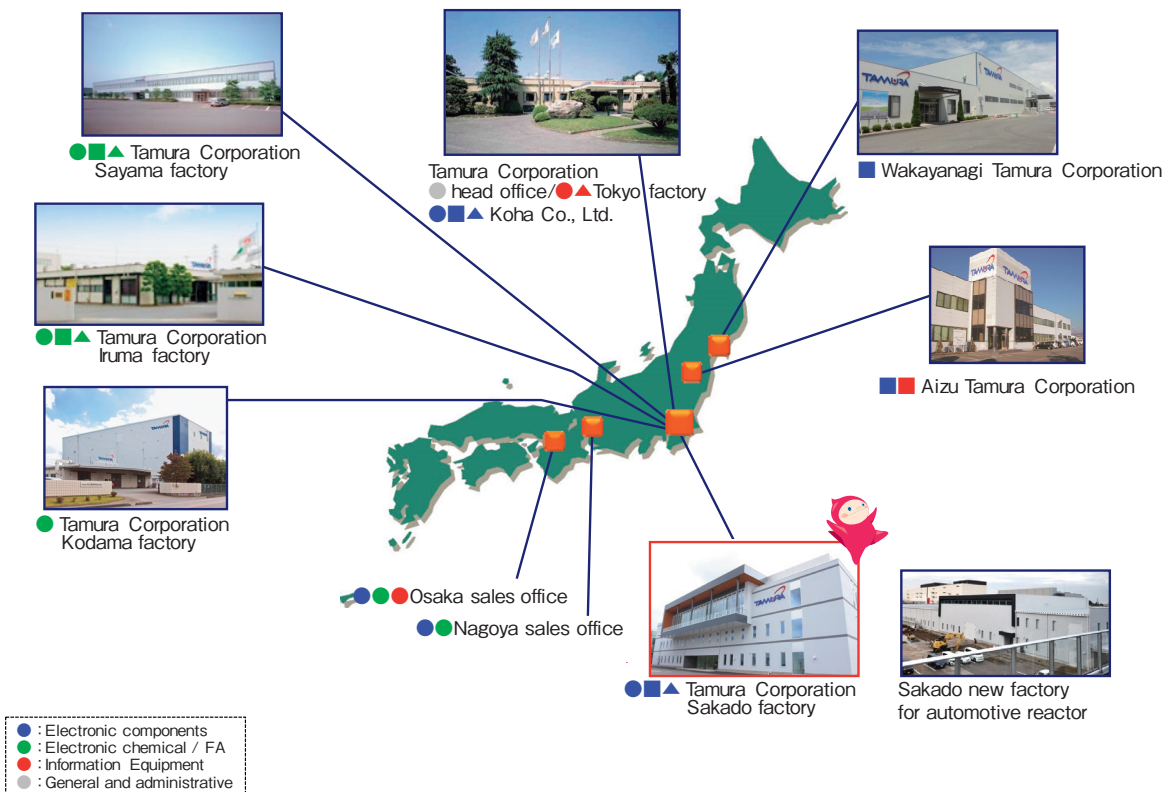

Outlines / Applications / Features

Introduction

Fluxgate system

Open loop

Closed loop

Outlines

The current sensor is a sensor to measure the current as its name. However, The current is various. There is a current value up to 10k amperes treated in the power plant from 1mA, and the shape of current waves also has AC, DC, and AC + DC. Since a method and a structure the best in each measuring object are different, there are also various current sensors. Tamura supplies the sensor using the Hall-Effect system for measuring the current value from several amperes to several kilo-ampere.

The Hall-Effect current sensor measures the magnetic flux produced in proportion to the primary current without any direct contact with the primary circuit; the combination of the Hall element and magnetic circuit provide excellent solution for measuring AC/ DC current with galvanic isolation and zero insertion loss.

The diagram in Figure-1 depicts the Hall current sensor basic principle. The magnetic flux produced in proportion to the primary current, I_f , induced in the magnetic circuit, passes through the Hall element inserted in the gap of the magnetic circuit resulting in a potential difference, V_h , expressed by the following formula:

Applications

Current control and detection of over-current in various types of inverters. Used for general-purpose inverter, various types of power conversion equipment to control and to detect over-current. Also used to measure DC current from the battery.

- Various types of inverters (CVCF, vector), Industrial robots, automation, devices, NC
- UPS, Elevator, Laser Cutting Machines, Welding Machines, Various types of Regulated Power Supply
- Solar power generation systems, Wind power systems, Fuel cell systems

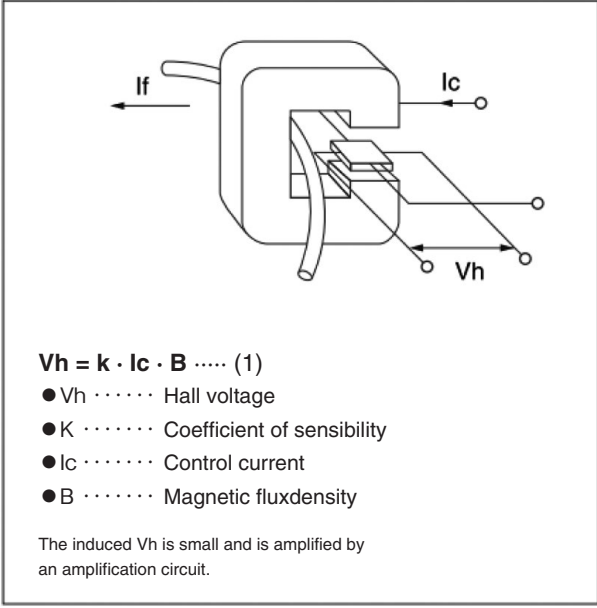

Figure-1

Features

Measurement of DC, AC (kHz range), & complex current (AC+DC). The lineup of rated currents ranges from a few A to over 1000 A.

- Galvanic isolation with many UL compliant configurations.
- Fast response time
- High Reliability

Applications of Current Sensor

Applications

Series (Example)

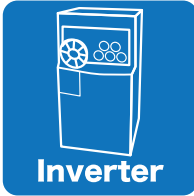

L18P	L07P	L06P	L03S
L37S	L34S	LA**P	S27S
S28S	S29S	S30S	S42S



L18P	L08P	L06P	L03S
L37S	S21S	S22S	S27S
S28S			

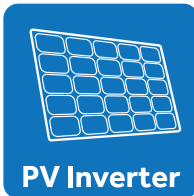

L18P	L34S	L40S	L51S
S22P	S23P	S30S	S42S
LA**P	F**P		



L03S	L37S	L07P	L08P
S22P	S23P	S21S	S27S
F**P			



L03S	L37S	L08P	L34S
S28S	S29S		













L18P	L12P	F**P	S22P
S23P	S21S	S27S	S28S
S29S			

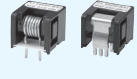











L03S	L37S	L08P	L06P
L34S	S21S	S27S	S28S
S29S			

Current Sensor / Guide map

Current range	SERIES	Model	Main Specification					UL R/C	Features	Page
			Circuit System	Mounting Configuration	Primary Conductor	Rated Current	Power Voltage			
6A ~ 150A	F01P 	F01PxxxS05L	Fluxgate system	On-board	Built-in bus-bar	6~50A	+5V	●	<ul style="list-style-type: none"> • Super precision & High stability • F02P & F03P : With reference access • F03P : Longer creepage and clearance distances 	19
	F02P 	F02PxxxS05L								
	F03P 	F03PxxxS05L								
	F23P 	F23PxxxS05R	Fluxgate system	On-board	Built-in bus-bar	50~100A	+5V	●	<ul style="list-style-type: none"> • Super precision & High stability • With reference access 	37
	F26P 	F26PxxxS05	Fluxgate system	On-board	Through hole □20.5×11	50~150A	+5V	●	<ul style="list-style-type: none"> • Super precision & High stability • With reference access (Ref_in / Ref_out), * F26P150S12 has only Vref (OUT) function • Suffix - "A" ; Improved output voltage waveform distortion 	42
		F26PxxxS05A								
F26P150S12		150A				+12V				
3A ~ 2500A	L18P 	L18PxxxD15AHV L18PxxxD15-OP	Open loop	On-board	Built-in coil/ bus-bar	3~60A	±15V	●	<ul style="list-style-type: none"> • Low cost • Compact, high performance • Name end "AHV": Anti-Sulfurated (Coating), Improve dvdt characteristics • Name end "R"; Rated voltage change 	62
		L18PxxxS05 L18PxxxS05R					+5V			
		L18PxxxS12					+12V			
	L07P 	L07PxxxD15 L07PxxxD15S	Open loop	On-board	Built-in coil	3~30A	±15V	●	<ul style="list-style-type: none"> • Low cost • Built-in 2 circuits • Name end "S"; Anti-Sulfurated (Coating, Anti-Sulfurated resistance) 	69
		L07PxxxS05					+5V			
	LA17P 	LA17PxxxS05	Open loop	On-board (Discrete)	Built-in bus-bar	10~50A	+5V	●	<ul style="list-style-type: none"> • Open loop - one chip ASIC model • With reference access • Non ratiometric output (Vout, Voff, Vref) 	112
	L12P 	L12P025D15	Open loop	On-board	Built-in coil	25A	±15V	●	<ul style="list-style-type: none"> • Low cost • Compact 	72
	L32P 	L32PxxxS05BFS	Open loop	On-board	Built-in bus-bar	50A, 100A	+5V	●	<ul style="list-style-type: none"> • Ferrite core is used. • With reference access • Used Anti-Sulfurated resistance 	73
		L32PxxxS05FS			Through hole □15×8	50~400A				
	L08P 	L08PxxxD15IPV/ W/IPVW	Open loop	On-board	Through hole φ16	50~500A	±15V	●	<ul style="list-style-type: none"> • Wide range of applications • Improve dV/dt characteristics 	74
L01Z 	L01ZxxxS05	Open loop	On-board	Through hole □15×8	50~600A	+5V	●	<ul style="list-style-type: none"> • Wide electrical current range • Compact 	77	

Current Sensor / Guide map

Current range	SERIES	Model	Main Specification					UL R/C	Features	Page	
			Circuit System	Mounting Configuration	Primary Conductor	Rated Current	Power Voltage				
3A ? 2500A	LA37S 	LA37SxxxS05M LA37SxxxS05J	Open loop	Connector (MOLEX/JST)	Through hole □20.3×10.3	50~600A	+5V	●	<ul style="list-style-type: none"> • Succession model of L37SxxxS05 series • Open loop - one chip ASIC model • Rated output voltage : Vof ±800mV or ±625mV • With reference access • Non ratiometric output 	78	
		LA37SxxxS05KM LA37SxxxS05KJ									
	L37S 	L37SxxxS05M L37SxxxS05J	Open loop	Connector (MOLEX/JST)	Through hole □20.4×10.4	50~600A	+5V	●	<ul style="list-style-type: none"> • Design for lower dvdt noise • L37SxxxD15x : Succession model of L03SxxxD15W series • L37SxxxS05x : With reference access • Wide electrical current range • Compact 	88	
		L37SxxxD15M L37SxxxD15J				50~600(800)A	±15V				
	L03S 	L03SxxxD15	Open loop	Connector (MOLEX)	Through hole □20.5×10.5	50~600A	±15V	●	<ul style="list-style-type: none"> • Wide electrical current range • Compact • Name end"W"; Saturation current up, Change position of CN (MOLEX or JST) 	94	
		L03SxxxD15WM L03SxxxD15WJ		Connector (MOLEX/JST)		50~800A					
	3A ? 2500A	L31S 	L31SxxxS05FS	Open loop	Connector (MOLEX)	Through hole □20.5×10.5	50~600A	+5V	●	<ul style="list-style-type: none"> • Wide electrical current range • Ferrite core is used. • With reference access • Used Anti-Sulfurated resistance 	96
		L06P 	L06PxxxS05	Open loop	On-board	Through hole φ22	300~800A	+5V	●	<ul style="list-style-type: none"> • Wide range of applications • Single power supply type 	97
		L05Z 	L05Z800S15	Open loop	Connector (JST)	Through hole □20.5×10.5	800A	+15V	●	<ul style="list-style-type: none"> • Wide range of applications • Single power supply type 	98
		L34S 	L34SxxxD15	Open loop	Connector (MOLEX)	Through hole □40.5×40.5	200~1500A	±15V	●	<ul style="list-style-type: none"> • Large aperture • Wide electrical current range • Suffix - "T"; Wide temperature range (-40 ~ +105°C) 	99
			L34SxxxD15T								
		L40S 	L40SxxxD15M L40SxxxD15J	Open loop	Connector (MOLEX/JST)	Through hole □30.5×40.5	200~1500A	±15V	●	<ul style="list-style-type: none"> • Succession model of L34SxxxD15T series • High-current (1500A_max) • Large aperture • Suffix - "C"; 1500V DC system voltage applicable 	103
			L40SxxxD15CM L40SxxxD15CJ								
L51S 		L51SxxxD15LM L51SxxxD15LJ	Open loop	Connector (MOLEX/JST)	Through hole □21.0×64.0	500~2500A	±15V	●	<ul style="list-style-type: none"> • High-Current (2500A_max) • Large aperture • Suffix- "(none)": Inner wall height 7mm, Suffix- "L"; 3.3mm • Suffix- "C"; 34mm. 1500V DC system voltage applicable 	107	
		L51SxxxD15M L51SxxxD15J									
		L51SxxxD15CM L51SxxxD15CJ									
6A ? 2000A		S22P 	S22PxxxS05M2 S22PxxxS05P	Closed loop	On-board	Built-in bus-bar	6~25A	+5V	●	<ul style="list-style-type: none"> • Voltage - output type • Name end"M2"; Backward compatible of normal model, External magnetic field improvement model • Name end "P"; Short lead model of normal model 	117







Introduction

Fluxgate system

Open loop

Closed loop

Current Sensor / Guide map

Current range	SERIES	Model	Main Specification					UL R/C	Features	Page
			Circuit System	Mounting Configuration	Primary Conductor	Rated Current	Power Voltage			
6A ? 2000A	S23P 	S23PxxxD15M2 S23PxxxD15M1 S23PxxxD15	Closed loop	On-board	Built-in bus-bar	100A	±15V	●	<ul style="list-style-type: none"> High accuracy, High performance Name end "M2": Backward compatible, dv/dt improvement type Name end "M1": Conversion Ratio 1:1000 Conversion Ratio - Normal & M2 type are 1:2000 	119
	S21S 	S21S180D15JN	Closed loop	Connector (JST)	Through hole R10	180A	±15V	●	<ul style="list-style-type: none"> Semicircle aperture Conversion Ratio 1:4000 	122
	S27S 	S27S300D15Y S27S300D15YM	Closed loop	Connector (MOLEX)	Through hole φ20	300A	±20V	●	<ul style="list-style-type: none"> High accuracy, High performance Conversion Ratio 1:2000 Connector: MOLEX (2 type) 	123
	S28S 	S28S500D24Z S28S500D24ZM	Closed loop	Connector (MOLEX)	Through hole φ30	500A	±24V	●	<ul style="list-style-type: none"> High-current, High accuracy Conversion Ratio 1:5000 Connector: MOLEX (2 type) 	125
	S29S 	S29S1T0D24Z S29S1T0D24ZM S29S1T0D24ZJ	Closed loop	Connector (MOLEX/JST)	Through hole φ38.5	1000A	±24V	●	<ul style="list-style-type: none"> High-current, High accuracy Conversion Ratio 1:5000 Connector: MOLEX (2 type), JST (1 type) 	127
	S30S 	S30S2T0D24Z S30S2T0D24ZM S30S2T0D24ZJ	Closed loop	Connector (MOLEX/JST)	Through hole φ61	2000A	±24V	●	<ul style="list-style-type: none"> High-current, High accuracy Conversion Ratio 1:5000 Connector : MOLEX (2 types), JST (1 type) 	129
	S42S 	S42S1T0D24Z S42S1T0D24ZM S42S1T0D24ZJ	Closed loop	Connector (MOLEX/JST)	Through hole φ42	1000A	±24V	●	<ul style="list-style-type: none"> High-current, High accuracy Conversion Ratio 1:5000 Connector : MOLEX (2 types), JST (1 type) 	133

Introduction

Fluxgate system

Open loop

Closed loop

Circuit system

Tamura offers multiple current sensor options to meet application requirements: Open Loop or Linear type (magnetic proportionality); Closed Loop or Servo-type (magnetic balance); Flux-Gate (magnetic equilibrium).

Open loop

If the current is applied to the cable, the magnetic field proportional to the current in surroundings of the cable is generated on Ampere's rule. The magnetic core is set in surroundings of the cable to improve the sensitivity. The Magnetic field is converted into the voltage by the linear type - hall element is placed in the gap of the magnetic core. But the output voltage of hall element is several tens of milli-volt, It enlarges it to the output voltage of the product specification (several volts) by the operational amplifier.

The sensor output voltage is linearly proportional to the magnetic flux generated by the measured current. In general, the open loop sensor is voltage output. The characteristic (accuracy, linearity, response, temperature property, and high-frequency current*1, etc.) of the current sensor is not a little better than that of other circuit methods because of the difference of the circuit configuration (magnetic circuit, magnetism-electric conversion and amplification of electrical circuit). However, the size can be reduced and it is lower-cost more than other circuit methods.

*1-We use silicon steel and permalloy in internal magnetic core of the open-loop sensors in order to improve the measurement possible current and hysteresis error. Therefore, at the frequency of the applied current exceeds more than several KHz, there is a possibility that the internal circuit may be damaged by the heat generation of the core loss.

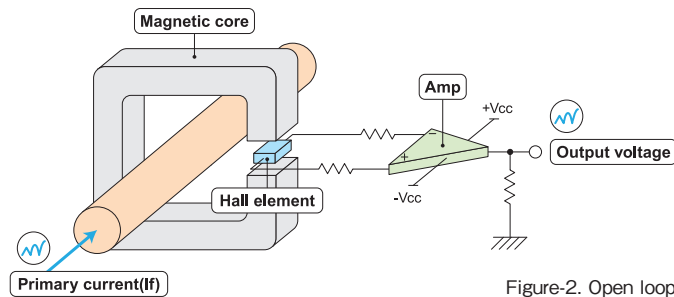

Figure-2. Open loop

Closed loop

The closed loop type current sensor measures the applied current on the condition that the magnetic flux density in the magnetic core is extremely zero. Therefore, there is no influence on accuracy by the non-linearity and hysteresis in the core because the flux density in the magnetic core operates in the starting point of the B-H curve in the operation region*1. The characteristic of the closed loop type is better than the open loop type current sensor.

The addition of a secondary winding (1000-5000 turns) on the magnetic core allows feedback current to be supplied in opposition to measured current to compensate or cancel the magnetic flux generated by the measured current. The output of the closed loop sensor is a current output proportional to the measured current divided by the number of secondary winding turns*2.

*1-At the high-frequency current (1-2kHz or more) and the pulse current, current sensor should operate at ACCT (transformer) because the loop gain of the feedback control decreases. Under such a condition, the magnetic flux in the magnetic core is generated.

*2-Output current = (Primary current) / (Secondary winding turns)

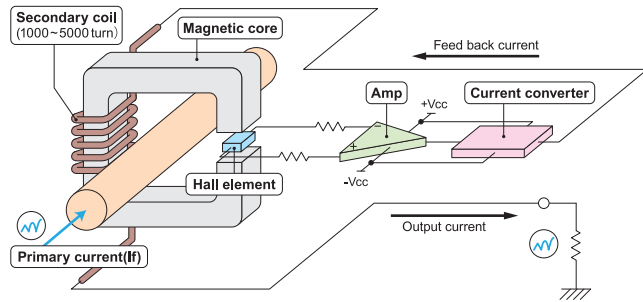

Figure-3. Closed loop

Fluxgate system

The flux-gate current sensor replaces the Hall element with probe coil made of highly saturable material. The magnetic offset of the probe coil does not occur in order to be driven by high-frequency current. The flux-gate utilizes a magnetic balance system to achieve high accuracy, temperature stable current output typically converted to a voltage output with an internal high precision resistor.

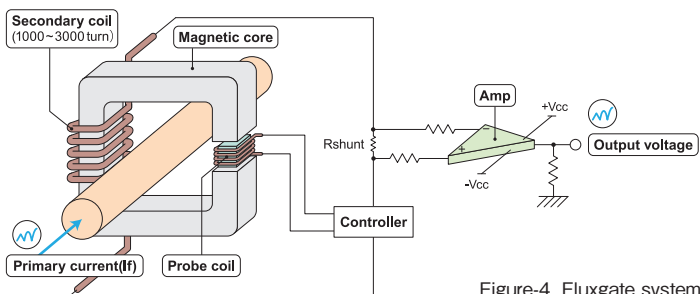

Figure-4. Fluxgate system

Application notes

Introduction

Fluxgate system

Open loop

Closed loop

<General Considerations>

1. The sensor uses polar electronic components. When the polarity of the power supply is mistaken, the sensor is damaged.
2. Static electricity or excessive voltage can increase an offset voltage in the Hall element, and cause offset voltage to change. Please exercise care in handling and application.
3. In order to prevent the influence of noise, the use of twisted cable or shielded cable for the output line is recommended
4. If using this device within a magnetic field generated by other devices, the specified accuracy may not be obtainable.
5. Our products (several models are excluded) are adjusted with the trimming method by the measurement condition (Load resistance, Power supply voltage) of specification sheets. Therefore, characteristics (Offset, Output, etc.) and its deviation may be changed in different circuit conditions from the measurement condition. All change characteristic items are not indicated on specification sheets.
6. The performance of current sensors with through-hole (aperture) is dependent on the position of the primary conductor. Tamura specifications are based on a primary conductor completely filling the through-hole (aperture) area.
7. The current sensor rated current in DC Amps.
8. Please use mating connector with equivalent terminal plating material to insure proper operation and avoid possibility of 'galvanic corrosion' .
9. Please do not store in high-temperature and high-humidity storage environment. Please use it after confirming soldering when it is kept for six months or more. (product soldered with substrate)
10. We recommend performing a zero offset adjustment by measuring the offset voltage at startup. In continuously operation for a few months, or at change of ambient temperature or humidity is large, we recommend regularly performing a zero offset adjustment at being idling (it is clear that the current is not apply) .
11. The current sensor doesn't have built-in protection circuit (devices and fuses, etc.). As a failure mode of the sensor, there is a short circuit and open state. In the case of a short-circuit state, the abnor-mal temperature rise of the internal parts is assumed, and there is a possibility to smoke and to ignite. If it is used in safety critical circuit blocks, please take appropriate measures by protection devices, protection circuits, etc. For closed loop -type sensors and flux gate (closed loop type) sensors, the consumption current of the secondary power supply varies in proportion to the measurement current.

<Open loop>

1. High frequency primary current may result in excessive heating in iron magnetic core and cause damage to internal circuitry; for high frequency applications select current sensor with ferrite core material.
2. If the measured current exceeds the rated current, magnetic core saturation will occur and the output voltage signal will not be linearly proportional to the measured current.

<Closed Loop>

1. For closed loop current sensors please insure the power supply voltage is balanced, symmetrical, and, applied simultaneously to avoid potential increase in DC offset error.
2. Maximum rated current measurement duration is timedependent. Maximum rated current applied in excess of the time limit can result in damage to internal electronic circuitry; please consult Tamura for assistance.
3. When using a measurement resistor to convert current output to voltage output select a resistor with stable temperature characteristic to insure accuracy of the output voltage.
4. Compensation current supplied to the secondary winding varies in proportion to the measured current based on the conversion ratio. (If/ KN ; KN = secondary turns) Please insure the PSU has required current capacity to supply compensation current to the secondary winding.

<Flux-Gate>

1. Compensation current supplied to the secondary winding varies in proportion to the measured current. Please insure the PSU has required current capacity to supply compensation current to the secondary winding.
2. There is 450kHz ripple voltage present on the output and reference output voltage signals . An external capacitor maybe added if necessary.

Part numbering system

Outlines

Ex)

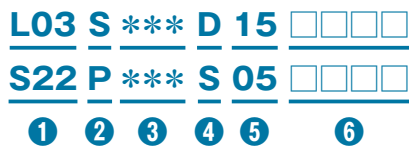

1 Model (3 figures or 4 figures)

- L ** : Open loop system (Magnetic Proportion System)
- S ** : Closed loop system (Servo system)
- F ** : Fluxgate system
- LA ** : Open loop system - One chip ASIC

2 Mounting configuration (1 figure)

- P : Through Hole Mounting Device
- M : Surface Mount Device
- S : Bolt-on Device

3 Rated current (3 figures)

Ex)

- 2R5 : 2.5A 005 : 5A
- 050 : 50A 500 : 500A
- 1T0 : 1000A

4 Control power supply type (1 figure)

- S : Single supply D : Dual supply

5 Power supply voltage (2 figures)

- 15 : 15V 05 : 5V

6 Special specification (4 figures_MAX.)

Ex)

Figures	Special specification
B	With a busbar
C	With a cover
J	Connector Maker : JST
M	Connector Maker : Molex
W	Saturation current is increased.
X	Secondary coil :1000 Turns
Z	Secondary coil : 5000 Turns
Y	Secondary coil : 2000 Turns

Important Notice

1. The content of this information is subject to change without prior notice for the purpose of improvements, etc. Ensure that you are in possession of the most up-to-date information when using this product.
2. This product is intended to be used in general electronics applications (electric home appliances, business equipment, information equipment, communication terminal equipment, measuring devices, industrial equipment, and so on). This product is neither intended nor warranted for use in following equipment or devices:
 - Special application (such as for medical devices, transportation equipment, traffic signal control equipment, fire and crime prevention equipment, aeronautics and space devices, nuclear power control, fuel control, in-vehicle equipment, safety devices, and so on) in which extremely high quality and high reliability is required, or if the malfunction or failures of product could be cause loss of human life, bodily injury.

Tamura Corporation shall not be held responsible for any damage incurred by customers or any third party when products are used in special application, unless specifically permitted in this document.
3. Tamura Corporation constantly strives to improve quality and reliability, but malfunction or failures are bound to occur with some probability in current sensor. To ensure that failures do not cause accidents resulting in injury or death, fire accidents, social damage, and so on, users are to thoroughly verify the safety of their designs in devices and/or systems.
4. The operation examples and circuit examples shown in this information are for reference purposes only, and Tamura Corporation disclaims all responsibility for any violations of industrial property rights, intellectual property rights and any other rights owned by Tamura Corporation or third parties that these may entail.
5. The circuit examples and part constants listed in these specifications are provided as reference for the verification of characteristics. The user is to perform design, verification, and judgment under his or her own responsibility, taking into account the various conditions.
6. The products are designed for use in environments where consumer electronics are commonly used. It is not designed for use in special environments such as listed below, and if such use is considered, the user is to perform thorough safety and reliability checks under his/her responsibility.
7. This product is not designed to resist radiation.
 - Use in liquids such as water, oil, chemical solutions, or organic solvents, and use in locations where the product will be exposed to such liquids.
 - Use that involves exposure to direct sunlight, outdoor exposure, or dusty conditions.
 - Use in locations where corrosive gases such as sea winds, Cl₂, H₂S, NH₃, SO₂, or NO₂, are present. (Some product improves durability)
 - Use in environments with strong static electricity or electromagnetic radiation.
 - Use that involves placing inflammable material next to the product.
 - Use of this product either sealed with a resin filling or coated with resin.
 - Use of water or a water soluble detergent for flux cleaning.
 - Use in locations where condensation is liable to occur.
8. Do not use or otherwise make available the TAMURA products or the technology described in this document for any military purposes, including without limitation, for the design, development, use, stockpiling or manufacturing of mass destruction weapons (e.g. nuclear, chemical, or biological weapons or missile technology products). When exporting and re-exporting the products or technology described in this document, you should comply with the applicable export control laws and regulations and follow the procedures required by such laws and regulations including, without limitation, Japan -Foreign Exchange and Foreign Trade Control Law and U.S.-Export Administration Regulations. The TAMURA products and related technology should not be used for or incorporated into any products or systems whose manufacture, use, or sale is prohibited under any applicable domestic or foreign laws or regulations.
9. Please contact your TAMURA sales office for details as to environmental matters such as the RoHS compatibility of Product. Please use TAMURA products in compliance with all applicable laws and regulations that regulate the inclusion or use of controlled substances, including without limitation, the EU RoHS Directive. TAMURA assumes no liability for damages or losses occurring as a result of your noncompliance with applicable laws and regulations.
10. TAMURA assumes no liability for damages or losses incurred by you or third parties as a result of unauthorized use of TAMURA products.
11. This document and any information herein may not be reproduced in whole or in part without prior written permission from TAMURA.

According to UL508 standard and CSA C22.2 No.14 standard

UL FILE No. E243511 Power Circuit and Motor-mounted Apparatus - Component

Series	Model	Requirements Evaluated to (US and/or CN)
F01P	F01P *** S05	USR
F02P	F02P *** S05	USR
F03P	F03P *** S05	USR
F23P	F23P *** S05R	USR, CNR
F26P	F26P *** S05 F26P *** S05A F26P *** S05B	USR
L07P	L07P *** D15 L07P *** D15S L07P *** S05	USR, CNR
L18P	L18P *** D15 L18P *** D15C L18P *** D15-OP L18P *** D15AH L18P *** S05 L18P *** S05R L18P *** S12 SL18P *** D15 L18P *** D15AHV L18P *** D15L	USR, CNR
L31S	L31S *** S05S L31S *** S05FS	USR, CNR USR
L32P	L32P *** S05FS L32P *** S05BFS	USR
L34S	L34S *** D15 L34S *** D15C L34S *** D15T L34S *** D15TC	USR, CNR
L37S/ L37P	L37S *** D15J L37S *** D15M L37S *** D15LJ L37S *** D15LM L37P *** D15 L37S *** S05J L37S *** S05M L37S *** D15EY L37S *** D15EJ L37S *** D15EM	USR USR, CNR
L51S	L51S *** D15J L51S *** D15M L51S *** D15LJ L51S *** D15LM L51S *** D15CJ L51S *** D15CM	USR, CNR

Note
 US indicates United States Standard.
 CN indicates Canadian National Standard.

Ratings - Environmental

Series	Model	Environmental	
		Maximum Surrounding Air Temperature rating	Pollution Degree
F01P	F01P *** S05	105°C.	2
F02P	F02P *** S05	105°C.	2
F03P	F03P *** S05	105°C.	2
F23P	F23P *** S05R	85°C.	2
F26P	F26P *** S05 F26P *** S05A F26P *** S05B	85°C.	2
L07P	L07P *** D15 L07P *** D15S L07P *** S05	80°C.	2
L18P	L18P *** D15 L18P *** D15C L18P *** D15-OP L18P *** D15AH L18P *** S05 L18P *** S05R L18P *** S12 SL18P *** D15 L18P *** D15AHV L18P *** D15L	80°C.	2
L31S	L31S *** S05S L31S *** S05FS	85°C.	2
L32P	L32P *** S05FS L32P *** S05BFS	85°C.	2
L34S	L34S *** D15 L34S *** D15C	80°C.	2
L34S	L34S *** D15T L34S *** D15TC	105°C.	2
L37S/ L37P	L37S *** D15J L37S *** D15M L37S *** D15LJ L37S *** D15LM L37P *** D15 L37S *** S05J L37S *** S05M L37S *** D15EY L37S *** D15EJ L37S *** D15EM	85°C.	2
L51S	L51S *** D15J L51S *** D15M L51S *** D15LJ L51S *** D15LM L51S *** D15CJ L51S *** D15CM	105°C.	2

Note
 Models F01P; followed by 006, 015, 025 or 050, followed by S05, may be followed by D, or L, may be followed by slash and any numbers from 01 through 99 or blank.
 Models F02P; followed by 001 through 075 or 1R1 through 74R9, followed by S05, may be followed by -PF, may be followed by slash and any numbers from 01 through 99 or blank.
 Models F03P; followed by 006, 015, 025 or 050, followed by S05, may be followed by D, L, -P1, -P2, -P3, -P4, -P5, -P6, -P7, -PB, -P9, -PA, -PB, -PC, -PD, -PE or -PF, may be followed by slash and any numbers from 01 through 99 or blank, may be prefixed by V. Models L37P and L37S; may be followed by "/" and two digits letter(s) and/or number (s) may be followed five digits "-", "/" and/or letter(s).

According to UL508 standard and CSA C22.2 No.14 standard

UL FILE No. E243511 Power Circuit and Motor-mounted Apparatus - Component

Series	Model	Requirements Evaluated to (US and/or CN)
LA02P	LA02P *** S03	USR, CNR
LA03P	LA03P *** S05	USR, CNR
LA17P	LA17P *** S05	USR, CNR
LA37S	LA37S *** S05M LA37S *** S05J LA37S *** S05J1 LA37S *** S05KM LA37S *** S05KJ LA37S *** S05KJ1	USR, CNR
S21S	S21S180D15JN	USR, CNR
S22P	S22P *** S05 S22P *** S05P S22P *** S05M2	USR, CNR
S23P	S23P50/100D15 S23P50/100D15M1 S23P50/100D15M2	USR, CNR
S25P	S25P *** D15 *	USR, CNR
S26P	S26P200D15Y	USR, CNR
S27S	S27S300D15Y S27S300D15YM	USR, CNR
S28S	S28S500D24Z S28S500D24ZM	USR
S29S	S29S1T0D24Z S29S1T0D24ZM S29S1T0D24ZJ	USR
S30S	S30S2T0D24Z S30S2T0D24ZM S30S2T0D24ZJ	USR, CNR
S42S	S42S1T0D24Z S42S1T0D24ZM S42S1T0D24ZJ	USR, CNR
Z05P	Z05P *** S05 Z05P *** S05P	USR, CNR

Note
US indicates United States Standard.
CN indicates Canadian National Standard.

Note
Models LA17P; followed 01 through 199, followed by R, followed by 1 through 9, followed by S05 or S05P, may be followed by 0 through 8, may be followed by five digits "-", "/", and/or letter(s). Models LA37S; followed by 0 through 8, may be followed by five digits "-", "/", and/or letter(s), may be followed by "/" and two digits letter(s) and/or number(s).

CSA FILE No. 218328 Industrial control Equipment - Miscellaneous Apparatus

Series	Model	Requirements Evaluated to (US and/or CN)
L40S	L40S *** D15J L40S *** D15M L40S *** D15CJ L40S *** D15CM	USR, CNR

Note
US indicates United States Standard.
CN indicates Canadian National Standard.

Ratings - Environmental

Series	Model	Environmental	
		Maximum Surrounding Air Temperature rating	Pollution Degree
LA02P	LA02P *** S03	110°C.	2
LA03P	LA03P *** S05	110°C.	2
LA17P	LA17P *** S05	105°C.	2
LA37S	LA37S *** S05M LA37S *** S05J LA37S *** S05J1 LA37S *** S05KM LA37S *** S05KJ LA37S *** S05KJ1	105°C.	2
S21S	S21S180D15JN	80°C.	2
S22P	S22P *** S05 S22P *** S05P S22P *** S05M2	85°C.	2
S23P	S23P50/100D15 S23P50/100D15M1 S23P50/100D15M2	85°C.	2
S25P	S25P *** D15 *	85°C.	2
S26P	S26P200D15Y	85°C.	2
S27S	S27S300D15Y S27S300D15YM	85°C.	2
S28S	S28S500D24Z S28S500D24ZM	70°C.	2
S29S	S29S1T0D24Z S29S1T0D24ZM S29S1T0D24ZJ	85°C.	2
S30S	S30S2T0D24Z S30S2T0D24ZM S30S2T0D24ZJ	85°C.	2
S42S	S42S1T0D24Z S42S1T0D24ZM S42S1T0D24ZJ	85°C.	2
Z05P	Z05P *** S05 Z05P *** S05P	105°C.	2

Ratings - Environmental

Series	Model	Environmental	
		Maximum Surrounding Air Temperature rating	Pollution Degree
L40S	L40S *** D15J L40S *** D15M L40S *** D15CJ L40S *** D15CM	105°C.	2

According to UL508 standard and CSA C22.2 No.14 standard

Ratings - Electrical

Series	Model	Primary (Feed-through)	Secondary (Sensing)	
			Input	Output
F01P	F01P006S05	6 A, 600 Vrms	5 Vdc, 25 mA	2.5 ± 2.2 Vdc, ± 0.5 mA
	F01P015S05	15 A, 600 Vrms	5 Vdc, 30 mA	
	F01P025S05	25 A, 600 Vrms	5 Vdc, 35 mA	
	F01P050S05	50 A, 600 Vrms	5 Vdc, 55 mA	
F02P	F02P006S05	6 A, 600 Vrms	5 Vdc, 25 mA	2.5 ± 2.2 Vdc, ± 0.5 mA
	F02P015S05	15 A, 600 Vrms	5 Vdc, 30 mA	
	F02P025S05	25 A, 600 Vrms	5 Vdc, 35 mA	
	F02P050S05	50 A, 600 Vrms	5 Vdc, 55 mA	
	F02P***S05-PF	Max75 A, 600 Vrms	5 Vdc, Max 85 mA	
F03P	F03P006S05	6 A, 600 Vrms	5 Vdc, 25 mA	2.5 ± 2.2 Vdc, ± 0.5 mA
	F03P015S05	15 A, 600 Vrms	5 Vdc, 30 mA	
	F03P025S05	25 A, 600 Vrms	5 Vdc, 35 mA	
	F03P050S05	50 A, 600 Vrms	5 Vdc, 55 mA	
	F23P050S05R	50 A, 600 Vrms	5 Vdc, 55 mA	
F23P	F23P100S05R	100 A, 600 Vrms	5 Vdc, 110mA	2.5 ± 2.2 Vdc, ± 0.5 mA
	F26P050S05	50 A, 1000 Vrms	+5 Vdc, +60 mA	0 - 4.625 Vdc, 0 ± 0.35 mA
F26P050S05A	50 A, 1000 Vrms	+5 Vdc, +100 mA		
F26P	F26P100S05	100 A, 1000 Vrms	+5 Vdc, +100 mA	
	F26P100S05B	100 A, 600 Vrms	+5 Vdc, +100 mA	
L07P	F26P150S05	150 A, 1000 Vrms	+5 Vdc, +115 mA	
	L07P003D15	3 A, 600 Vrms	± 15 Vdc, ± 30 mA	0 - 4 Vdc, 0.4 mA
	L07P003D15S	3 A, 600 Vrms		
	L07P005D15	5 A, 600 Vrms		
	L07P005D15S	5 A, 600 Vrms		
	L07P010D15	10 A, 600 Vrms		
	L07P010D15S	10 A, 600 Vrms		
	L07P015D15	15 A, 600 Vrms		
L07P015D15S	15 A, 600 Vrms			
L07P	L07P020D15	20 A, 600 Vrms	5 Vdc, 30 mA	0 - 3.75 Vdc, 0.4 mA
	L07P020D15S	20 A, 600 Vrms		
	L07P025D15	25 A, 600 Vrms		
	L07P025D15S	25 A, 600 Vrms		
	L07P030D15	30 A, 600 Vrms		
	L07P030D15S	30 A, 600 Vrms		
	L07P003S05	3 A, 600 Vrms		
L07P005S05	5 A, 600 Vrms			
L07P010S05	10 A, 600 Vrms			
L07P015S05	15 A, 600 Vrms			
L07P020S05	20 A, 600 Vrms			
L07P025S05	25 A, 600 Vrms			
L07P030S05	30 A, 600 Vrms			

Series	Model	Primary (Feed-through)	Secondary (Sensing)	
			Input	Output
L18P	L18P***D15 L18P***D15-L L18P***D15-OP L18P***D15AH L18P***D15AHV L18P***D15C SL18P***D15	1 A through 60 A at 0.1 A increments, 600 Vrms	± 15 Vdc, ± 15 mA	0-4 Vdc, 0.4 mA
	*** : 001 through 060: 1 A through 60 A, 1R1 through 59R9: 1.1 A through 59.9 A (Step interval 0.1 A)			
L18P	L18P003S05	3 A, 600 Vrms	5 Vdc, 15 mA	0 - 4 Vdc, 0.4 mA
	L18P005S05	5 A, 600 Vrms		
	L18P010S05	10 A, 600 Vrms		
	L18P015S05	15 A, 600 Vrms		
	L18P020S05	20 A, 600 Vrms		
	L18P025S05	25 A, 600 Vrms		
	L18P030S05	30 A, 600 Vrms		
	L18P040S05	40 A, 600 Vrms		
L18P	L18P050S05	50 A, 600 Vrms	5 Vdc, 15 mA	0 - 3.2 Vdc, 0.32 mA
	L18P060S05	60 A, 600 Vrms		
	L18P003S05R	3 A, 600 Vrms		
	L18P005S05R	5 A, 600 Vrms		
	L18P010S05R	10 A, 600 Vrms		
	L18P015S05R	15 A, 600 Vrms		
	L18P020S05R	20 A, 600 Vrms		
	L18P025S05R	25 A, 600 Vrms		
L18P	L18P030S05R	30 A, 600 Vrms	12 Vdc, 15 mA	0 - 4 Vdc, 0.4 mA
	L18P040S05R	40 A, 600 Vrms		
	L18P050S05R	50 A, 600 Vrms		
	L18P060S05R	60 A, 600 Vrms		
	L18P003S12	3 A, 600 Vrms		
	L18P005S12	5 A, 600 Vrms		
	L18P010S12	10 A, 600 Vrms		
	L18P015S12	15 A, 600 Vrms		
L18P	L18P020S12	20 A, 600 Vrms	12 Vdc, 15 mA	0 - 4 Vdc, 0.4 mA
	L18P025S12	25 A, 600 Vrms		
	L18P030S12	30 A, 600 Vrms		
	L18P040S12	40 A, 600 Vrms		
	L18P050S12	50 A, 600 Vrms		
	L18P060S12	60 A, 600 Vrms		

Note

Models F01P; followed by 006, 015, 025 or 050, followed by S05, may be followed by D, or L, may be followed by slash and any numbers from 01 through 99 or blank. Models F02P; followed by 006, 015, 025 or 050, followed by S05, may be followed by D, L, -P0, -P1, -P2, -P3, -P4, -P5, -P6, -P7, -P8, -P9, -PA, -PB, -PC, -PD, -PE or -PF, may be followed by slash and any numbers from 01 through 99 or blank. Models F03P; followed by 006, 015, 025 or 050, followed by S05, may be followed by D, L, -P1, -P2, -P3, -P4, -P5, -P6, -P7, -P8, -P9, -PA, -PB, -PC, -PD, -PE or -PF, may be followed by slash and any numbers from 01 through 99 or blank, may be prefixed by V.

According to UL508 standard and CSA C22.2 No.14 standard

Ratings - Electrical

Series	Model	Primary (Feed-through)	Secondary (Sensing)	
			Input	Output
L31S	L31S050S05S L31S050S05FS	50 A, 600 Vrms	5 Vdc, 15 mA	1.875 - 3.125 Vdc, 0.3125 mA
	L31S100S05S L31S100S05FS	100 A, 600 Vrms		
	L31S200S05S L31S200S05FS	200 A, 600 Vrms		
	L31S300S05S L31S300S05FS	300 A, 600 Vrms		
	L31S400S05S L31S400S05FS	400 A, 600 Vrms		
	L31S500S05S L31S500S05FS	500 A, 600 Vrms		
	L31S600S05S L31S600S05FS	600 A, 600 Vrms		
	L32P	L32P050S05FS L32S050S05BFS		
L32P100S05FS L32P100S05BFS		100 A, 600 Vrms		
L32P150S05FS		150 A, 600 Vrms		
L32P200S05FS		200 A, 600 Vrms		
L32P300S05FS		300 A, 600 Vrms		
L32P400S05FS		400 A, 600 Vrms		
L34S	L34SxxxD15 L34SxxxD15T	600 Vrms	± 15 Vdc, ± 25 mA	0 - 4 Vdc, 0.4 mA
	L34SxxxD15C L34SxxxD15TC	1500 Vrms		
	L34S200D15 L34S200D15C L34S200D15T L34S200D15TC	200 A		
	L34S300D15 L34S300D15C L34S300D15T L34S300D15TC	300 A		
	L34S400D15 L34S400D15C L34S400D15T L34S400D15TC	400 A		
	L34S500D15 L34S500D15C L34S500D15T L34S500D15TC	500 A		
	L34S600D15 L34S600D15C L34S600D15T L34S600D15TC	600 A		
	L34S800D15 L34S800D15C L34S800D15T L34S800D15TC	800 A		
	L34S1T0D15 L34S1T0D15C L34S1T0D15T L34S1T0D15TC	1000 A		
	L34S1T2D15 L34S1T2D15C L34S1T2D15T L34S1T2D15TC	1200 A		
	L34S1T5D15 L34S1T5D15C L34S1T5D15T L34S1T5D15TC	1500 A		

Note

Models L37P and L37S; may be followed by "/" and two digits letter(s) and/or number(s) may be followed by five digits "-", "/" and/or letter(s).

Series	Model	Primary (Feed-through)	Secondary (Sensing)				
			Input	Output			
L37S	L37S050D15J L37S050D15M L37S050D15LJ L37S050D15LM	50 A, 600 Vrms	± 15 Vdc, ± 25 mA	0 - 4 Vdc, 0.4 mA			
	L37S100D15J L37S100D15M L37S100D15LJ L37S100D15LM	100 A, 600 Vrms					
	L37S200D15J L37S200D15M L37S200D15LJ L37S200D15LM	200 A, 600 Vrms					
	L37S300D15J L37S300D15M L37S300D15LJ L37S300D15LM	300 A, 600 Vrms					
	L37S400D15J L37S400D15M L37S400D15LJ L37S400D15LM	400 A, 600 Vrms					
	L37S500D15J L37S500D15M L37S500D15LJ L37S500D15LM	500 A, 600 Vrms					
	L37S600D15J L37S600D15M L37S600D15LJ L37S600D15LM	600 A, 600 Vrms					
	L37S	L37S050D15EY L37S050D15EJ L37S050D15EM			50 A, 1000 Vrms	± 15 Vdc, ± 25 mA	0 - 4 Vdc, 0.4 mA
		L37S100D15EY L37S100D15EJ L37S100D15EM			100 A, 1000 Vrms		
		L37S200D15EY L37S200D15EJ L37S200D15EM			200 A, 1000 Vrms		
L37S300D15EY L37S300D15EJ L37S300D15EM		300 A, 1000 Vrms					
L37S400D15EY L37S400D15EJ L37S400D15EM		400 A, 1000 Vrms					
L37S500D15EY L37S500D15EJ L37S500D15EM		500 A, 1000 Vrms					
L37S600D15EY L37S600D15EJ L37S600D15EM		600 A, 1000 Vrms					
L37S		L37S050S05J L37S050S05M	50 A, 600 Vrms	5 Vdc, 20 mA	2.5 ± 0.625 Vdc, 0.3125 mA		
		L37S100S05J L37S100S05M	100 A, 600 Vrms				
		L37S200S05J L37S200S05M	200 A, 600 Vrms				
	L37S300S05J L37S300S05M	300 A, 600 Vrms					
	L37S400S05J L37S400S05M	400 A, 600 Vrms					
	L37S500S05J L37S500S05M	500 A, 600 Vrms					
	L37S600S05J L37S600S05M	600 A, 600 Vrms					
	L37P	L37P050D15	50 A, 300 Vrms			± 15 Vdc, ± 25 mA	0 - 4 Vdc, 0.4 mA
		L37P100D15	100 A, 300 Vrms				
		L37P200D15	200 A, 300 Vrms				
L37P300D15		300 A, 300 Vrms					
L37P400D15		400 A, 300 Vrms					
L37P500D15 L37P600D15		500 A, 300 Vrms 600 A, 300 Vrms					

According to UL508 standard and CSA C22.2 No.14 standard

Ratings - Electrical

Series	Model	Primary (Feed-through)	Secondary (Sensing)		Series	Model	Primary (Feed-through)	Secondary (Sensing)					
			Input	Output				Input	Output				
L40S	L40S200D15J L40S200D15M	200 A, 600 Vrms	± 15 Vdc, ± 17 mA	0 ± 4.0Vdc, ± 0.4 mA	L51S	L51S500D15CJ L51S500D15CM	500 A, 1500 Vrms	± 15 Vdc, 25 mA	± 4 Vdc, 0.4 mA				
	L40S400D15J L40S400D15M	400 A, 600 Vrms				L51S600D15CJ L51S600D15CM	600 A, 1500 Vrms						
	L40S500D15J L40S500D15M	500 A, 600 Vrms				L51S850D15CJ L51S850D15CM	850 A, 1500 Vrms						
	L40S600D15J L40S600D15M	600 A, 600 Vrms				L51S1T0D15CJ L51S1T0D15CM	1000 A, 1500 Vrms						
	L40S800D15J L40S800D15M	800 A, 600 Vrms				L51S1T2D15CJ L51S1T2D15CM	1200 A, 1500 Vrms						
	L40S1T0D15J L40S1T0D15M	1000 A, 600 Vrms				L51S1T5D15CJ L51S1T5D15CM	1500 A, 1500 Vrms						
	L40S1T2D15J L40S1T2D15M	1200 A, 600 Vrms				L51S2T0D15CJ L51S2T0D15CM	2000 A, 1500 Vrms						
	L40S1T5D15J L40S1T5D15M	1500 A, 600 Vrms				L51S2T5D15CJ L51S2T5D15CM	2500 A, 1500 Vrms						
	L40S200D15CJ L40S200D15CM	200 A, 1500 Vrms				S21S	S21S180D15JN			180 A, 600 Vrms	± 15 Vdc, ± 25mA	0 - 1.35 Vdc, 45mA	
	L40S400D15CJ L40S400D15CM	400 A, 1500 Vrms					S22P			S22P006S05 S22P006S05P S22P006S05M2	6 A, 600 Vrms	5 Vdc, 12.5 mA	0 - 3.125 Vdc, 3mA
	L40S500D15CJ L40S500D15CM	500 A, 1500 Vrms								S22P015S05 S22P015S05P S22P015S05M2	15 A, 600 Vrms		0 - 3.125 Vdc, 7.5mA
	L40S600D15CJ L40S600D15CM	600 A, 1500 Vrms								S22P025S05 S22P025S05P S22P025S05M2	25 A, 600 Vrms		0 - 3.125 Vdc, 12.5mA
	L40S800D15CJ L40S800D15CM	800 A, 1500 Vrms					S23P			S23P50/100D15	100 A, 600 Vrms	MAX. ± 15 Vdc, ± 62.5 mA	-2.5 - 2.5 Vdc; -50 - 50mA
	L40S1T0D15CJ L40S1T0D15CM	1000 A, 1500 Vrms								S23P50/100D15M1	100 A, 600 Vrms	MAX. ± 15 Vdc, ± 112.5 mA	-5 - 5 Vdc; -100 - 100mA
	L40S1T2D15CJ L40S1T2D15CM	1200 A, 1500 Vrms								S23P50/100D15M2	100 A, 600 Vrms	MAX. ± 15 Vdc, ± 62.5 mA	-2.5 - 2.5 Vdc; -50 - 50mA
	L40S1T5D15CJ L40S1T5D15CM	1500 A, 1500 Vrms					S25P			S25P050D15X	50 A, 600 Vrms	MAX. ± 15 Vdc, ± 62.5 mA	-5 - 5 Vdc; -50 - 50mA
L51S	L51S500D15J L51S500D15M L51S500D15LJ L51S500D15LM	500 A, 600 Vrms	± 15 Vdc, 25 mA	± 4 Vdc, 0.4 mA	S25P			S25P100D15X	100 A, 600 Vrms	MAX. ± 15 Vdc, ± 112.5 mA	-5 - 5 Vdc; -100 - 100mA		
	L51S600D15J L51S600D15M L51S600D15LJ L51S600D15LM	600 A, 600 Vrms						S25P100D15Y	100 A, 600 Vrms	MAX. ± 15 Vdc, ± 62.5 mA	-5 - 5 Vdc; -50 - 50mA		
	L51S850D15J L51S850D15M L51S850D15LJ L51S850D15LM	850 A, 600 Vrms						S25P150D15Y	150 A, 600 Vrms	MAX. ± 15 Vdc, ± 87.5 mA	-3.75 - 3.75 Vdc; -75 - 75mA		
	L51S1T0D15J L51S1T0D15M L51S1T0D15LJ L51S1T0D15LM	1000 A, 600 Vrms					S26P	S26P200D15Y	200 A, 600 Vrms	MAX. ± 15 Vdc, ± 112.5 mA	-5 - 5 Vdc; -100 - 100mA		
	L51S1T2D15J L51S1T2D15M L51S1T2D15LJ L51S1T2D15LM	1200 A, 600 Vrms						S27S	S27S300D15Y S27S300D15YM	300 A, 600 Vrms	± 15 Vdc, ± 162.5 mA	0 - ± 7.5 Vdc, ± 150mA	
	L51S1T5D15J L51S1T5D15M L51S1T5D15LJ L51S1T5D15LM	1500 A, 600 Vrms					S28S		S28S500D24Z S28S500D24ZM	500 A, 600 Vrms	± 24 Vdc, ± 130 mA	0 - ± 5 Vdc, ± 100mA	
	L51S2T0D15J L51S2T0D15M L51S2T0D15LJ L51S2T0D15LM	2000 A, 600 Vrms						S29S	S29S1T0D24Z S29S1T0D24ZM S29S1T0D24ZJ	1000 A, 600 Vrms	± 24 Vdc, ± 235 mA	0 - ± 10 Vdc, ± 200mA	
	L51S2T5D15J L51S2T5D15M L51S2T5D15LJ L51S2T5D15LM	2500 A, 600 Vrms					S30S		S30S2T0D24Z S30S2T0D24ZM S30S2T0D24ZJ	2000 A, 600 Vrms	24 Vdc, 45 mA; -24 Vdc, -45 mA	0 - ± 10 Vdc, ± 400mA	
	S42S	S42S1T0D24Z S42S1T0D24ZM S42S1T0D24ZJ				1000 A, 600 Vrms		± 24 Vdc, ± 245 mA	± 10 Vdc, ± 200mA				

According to UL508 standard and CSA C22.2 No.14 standard

Series	Model	Primary (Feed-through)	Secondary (Sensing)									
			Input	Output								
LA02P	LA02P021S03 LA02P035S03 LA02P054S03 LA02P085S03	50 A, 480 Vac	3.3 Vdc, 0.5 mA	3.3 Vdc, 0.5 mA								
	LA03P				LA03P021S05 LA03P035S05 LA03P054S05 LA03P085S05	50 A, 480 Vac	5 Vdc, 0.5 mA	5 Vdc, 0.5 mA				
					LA17P				LA17PxxxS05	1-200 A, 600 Vrms	+5 Vdc, 15 mA	0 Vdc through 5 Vdc, reference voltage as follows
									with blank or 0 or 4			2.5 Vdc, 0 0.5 mA
with 1 or 5		1.65 Vdc, 0 0.5 mA										
with 2 or 6	1.5 Vdc, 0 0.5 mA											
with 3 or 7	0.5 Vdc, 0 0.5 mA											
with blank or 8	0.5 Vdc through 2.5 Vdc, 0 0.5 mA											

Series	Model	Primary (Feed-through)	Secondary (Sensing)				
			Input	Output			
LA37S	LA37S050S05@	50 A, 600 Vrms	+5 Vdc, max. 23 mA	2.5 ± 0.88 Vdc, 0.33 mA			
	LA37S100S05@				100 A, 600 Vrms		
	LA37S200S05@				200 A, 600 Vrms		
	LA37S300S05@				300 A, 600 Vrms		
	LA37S400S05@				400 A, 600 Vrms		
	LA37S500S05@				500 A, 600 Vrms		
	LA37S600S05@				600 A, 600 Vrms		
	LA37S050S05K@				50 A, 600 Vrms	+5 Vdc, max. 23 mA	2.5 ± 0.625 Vdc, 0.3125 mA
	LA37S100S05K@				100 A, 600 Vrms		
	LA37S200S05K@				200 A, 600 Vrms		
LA37S300S05K@	300 A, 600 Vrms						
LA37S400S05K@	400 A, 600 Vrms						
LA37S500S05K@	500 A, 600 Vrms						
LA37S600S05K@	600 A, 600 Vrms	@- Replaced with J, J1, M					
Z05	Z05POR3S05	300 mA, 600 Vrms	+5 Vdc, +17.5 mA	2.5 ± 2.2 Vdc, 0 ± 0.5 mA			
	Z05POR3S05P						
	Z05POR6S05	600 mA, 600 Vrms					
	Z05POR6S05P						

Note
 Models LA17P; followed 01 through 199, followed by R, followed by 1 through 9, followed by S05 or S05P, may be followed by O through 8, may be followed by five digits "-", "/" and/or letter(s). Models LA37S; followed by O through 8, may be followed by five digits "-", "/" and/or letter(s), may be followed by "/" and two digits letter(s) and/or number(s).

Conditions of Acceptability

- When installed in the end-use equipment, consideration shall be given to the following:

Common terms

- 1 The devices have been evaluated for use in pollution degree 2 environment only.
- 2 A suitable enclosure shall be provided in the end-use application
- 3 The terminals have not been evaluated for field wiring.
- 4 The devices are not intended to be used with any wire as the feed-through coil wound onto the Case.
- 5 The secondary sensing circuit shall be powered by an Isolated Secondary Circuit such as Limited Voltage/Current circuit or Limiting Impedance circuit.
- 6 The required clearance and creepage distance between primary conductor and the secondary circuits shall be maintained in the end-use application.
- 7 The housing of the female connector provided by the end-product shall be evaluated as a barrier under the end-application Standard in the end-use application, in case the clearance and/or the creepage distance do not meet the requirements of the end-application Standard.

Please refer to the next page for other items. If you have any question, please contact distributor or sales office.

According to UL508 standard and CSA C22.2 No.14 standard

CAUTION

The descriptions are directed from UL and CSA.

Series	Model	CAUTION / Notice
F01P	F01P *** S05	- / Notice : The maximum temperature at top of case shall not be higher than 110°C and busbar shall not be higher than 108°C in the end-use product.
F02P	F02P *** S05	
F03P	F03P *** S05	
F23P	F23P *** S05R	- / Notice: The devices have been evaluated with the provision of the two copper conductor-cum-heat sink as the primary conductor, measured 100 by 85 mm, 0.5 mm thick.
F26P	F26P *** S05 F26P *** S05A F26P *** S05B	- / Notice: All devices have been evaluated with the bus bar (20.5 mm x 11 mm (225.5 mm ²) x 170 mm long) under the temperature test. Based on this effect, the temperature of the bus bar was kept at 94.9°C
L07P	L07P *** D15 L07P *** D15S L07P *** S05	- / -
L18P	L18P *** D15 L18P *** D15C L18P *** D15-OP L18P *** D15AH L18P *** S05 L18P *** S05R L18P *** S12 SL18P *** D15 L18P *** D15AHV L18P *** D15L	- / -
L31S	L31S *** S05S L31S *** S05FS	- / Notice: Do not wrap the primary conductor around the core part of the product for preventing to reduce the required Spacings.
L32P	L32P *** S05FS L32P *** S05BFS	- / Notice: Do not wrap the primary conductor around the core part of the product for preventing to reduce the required Spacings. The maximum temperature at case should not exceed 150°C by the case's insulation performance.
L34S	L34S *** D15 L34S *** D15C L34S *** D15T L34S *** D15TC	CAUTION: Do not wrap the primary conductor around the core part of the product for preventing to reduce the required Spacings. / For models with suffix T in Temperature Rating designation detailed in NOMENCLATURE for models in L34S series and L34SC series, the maximum temperature of the bus bar (primary conductor) shall not exceed 135°C at the end-use application.
L37S	L37S *** D15J L37S *** D15M L37S *** D15LJ L37S *** D15LM L37P *** D15P L37S *** D15EY L37S *** D15EJ L37S *** D15EM L37S *** S05J L37S *** S05M	- / Notice: The housing of the female connector provided by the end-product shall be evaluated as a barrier under the end-application Standard in the end-use application, in case the clearance and/ or the creepage distance do not meet the requirements of the endapplication Standard. The maximum temperature of busbar shall not be higher than 102.3° C respectively at the end-use application.

Note

Models F01P; may be followed by 006, 015, 025 or 050, followed by S05, may be followed by D, or L, may be followed by slash and any numbers from 01 through 99 or blank. Models F02P; followed by 001 through 050 or 1R1 through 49R9, followed by S05, may be followed by D, L, -P0, -P1, -P2, -P3, -P4, -P5, -P6, -P7, -PB, -P9, -PA, -PB, -PC, -PD, -PE or -PF, may be followed by slash and any numbers from 01 through 99 or blank. Models F03P; followed by 006, 015, 025 or 050, followed by S05, may be followed by D, L, -P1, -P2, -P3, -P4, -P5, -P6, -P7, -PB, -P9, -PA, -PB, -PC, -PD, -PE or -PF, may be followed by slash and any numbers from 01 through 99 or blank, may be prefixed by V. Models L37P and L37S; may be followed by "/" and two digits letter(s) and/or number(s) may be followed by five digits "-", "/" and/or letter(s). Models LA17P; followed 01 through 199, followed by R, followed by 1 through 9, followed by S05 or S05P, may be followed by O through 8, may be followed by five digits "-", "/" and/or letter(s). Models LA37S; followed by O through 8, may be followed by five digits "-", "/" and/or letter(s), may be followed by "/" and two digits letter(s) and/or number(s).

According to UL508 standard and CSA C22.2 No.14 standard

CAUTION

The descriptions are directed from UL and CSA.

Series	Model	CAUTION / Notice
L40S	L40S *** D15J L40S *** D15M L40S *** D15CJ L40S *** D15CM	- / -
L51S	L51S *** D15J L51S *** D15M L51S *** D15LJ L51S *** D15LM L51S *** D15CJ L51S *** D15CM	- / The primary bus bar or conductor shall not exceed 120 C in the end use application.
LA02P	LA02P *** S03	- / -
LA03P	LA03P *** S05	- / -
LA17P	LA17P *** S05	- / The temperature of the primary terminal shall not exceed 120°C in the end-use applica-tion.
LA37S	LA37S *** S05 LA37S *** S05K	- / The maximum temperature of the primary conductor bus-bar equal to or lower than 120°C at the end-use application.
S21S	S21S180D15JN	CAUTION: Do not wrap the primary conductor around the core part of the product to increase measured current. / -
S22P	S22P *** S05 S22P *** S05P S22P *** S05M2	- / -
S23P	S23P50/100D15 S23P50/100D15M1 S23P50/100D15M2	CAUTION: Provide two min. 100 by 85 mm, 0.5mm thick copper conductor-cum- heat sink as primary conductor of each side for safe usage. / Notice : The primary conductor temperature and PCB should not exceed 100°C by the temperature regulations of internal parts.
S25P	S25P *** D15 *	CAUTION: Do not wrap the primary conductor around the core part of the product to increase measured current. / -
S26P	S26P200D15Y	CAUTION: Do not wrap the primary conductor around the core part of the product to increase measured current. / -
S27S	S27S300D15Y S27S300D15YM	- / Notice: Do not wrap the primary conductor around the core part of the product for preventing to reduce the required Spacings.
S28S	S28S500D24Z S28S500D24ZM	- / Notice : Do not wrap the primary conductor around the core part of the product for preventing to reduce the required Spacings. The maximum temperature at case should not exceed 140°C by the case's insulation performance.
S29S	S29S1T0D24Z S29S1T0D24ZM S29S1T0D24ZJ	- / Notice: Do not wrap the primary conductor around the core part of the product for preventing to reduce the required Spacings. The primary conductor temperature should not exceed 95°C by the temperature regulations of internal parts.
S30S	S30S2T0D24Z S30S2T0D24ZM S30S2T0D24ZJ	- / Notice: These devices have been evaluated with the bus bar cooled by Liquid CPU cooler, Type ELC-LMR240-BS manufactured by Enermax Technology Corporation. Based on this effect, the temperature of the bus bar was kept at 116.0°C. Other than this usage, an additional evaluation shall be considered and conducted in the end-use application.
S42S	S42S1T0D24Z S42S1T0D24ZM S42S1T0D24ZJ	- / Notice: These devices have been evaluated with the copper bus bar (Size φ 44mm L350mm) under the temperature test. Based on this effect, the temperature of the bus bar was kept at 138.5°C. Other than this usage, an additional evaluation shall be considered and conducted in the end-use application.
Z05P	Z05P *** S05 Z05P *** S05P	- / -

Introduction

Fluxgate system

Open loop

Closed loop

Fluxgate system / Voltage-output type, Anti-Surge current, Compact

F01P S05L, F02P S05L, F03P S05L SERIES

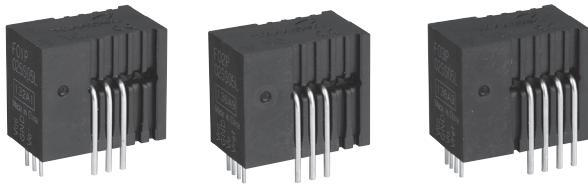

F01PxxxS05L F02PxxxS05L F03PxxxS05L



- Backward compatible to F01PxxxS05, F02PxxxS05, F03PxxxS05 Series.
- Anti-Surge current (4kAT, 8/20uS, single)
- Mounting area reduced, however, pin compatibility. Longitudinal dimension reduced.
- Super precision & High stability (Low temperature drift) .
- Unipolar power voltage; +5V. Rated Current; 6 ~ 50A. Multi-range models. MAX_Temp.105°C . Voltage-output type.
- F01PxxxS05L series are designed by the pin compatibility as high-end models of S22PxxxS05M2 series.

Comparison of the main features

Series	Features
F01PxxxS05L	Without reference access.
F02PxxxS05L	With reference access, Ref_in / Ref_out.
F03PxxxS05L	With reference access, Ref_in / Ref_out. Higher creepage and clearance distances.

***: Rated Current symbol

SPECIFICATIONS

Spec	Types	Value		
		F01PxxxS05L	F02PxxxS05L	F03PxxxS05L
Maximum peak current		4kAT (2kA × 2. Number of primary tunes is two tunes.)		
Rated Current If (xxx: Rated Current symbol)		6A (006) / 15A (015) / 25A (025) / 50A (050)		
Maximum current (At Vcc=+5V, Ta=+105°C)		± 20A (If=6A) / ± 51A (If=15A) / ± 85A (If=25A) / ± 150A (If=50A)		
Existence of reference access		No	Yes	
Number of primary busbar		3pcs		4pcs
Clearance distance, Primary ↔ Secondary		7.7mm	7.5mm	8.2mm
STANDARDS		UL508 (file No. E243511), EN50178, EN61010-1, EN60950-1		
Ambient operating temperature		- 40°C ~ +105°C		

Mounting area

The mounting area has been reduced more than the F01P / F02P / F03PxxxS05 series. However, the F01P / F02P / F03PxxxS05L series series are 100% compatible with the F01P / F02P / F03PxxxS05series in regards to the footprint mounting.

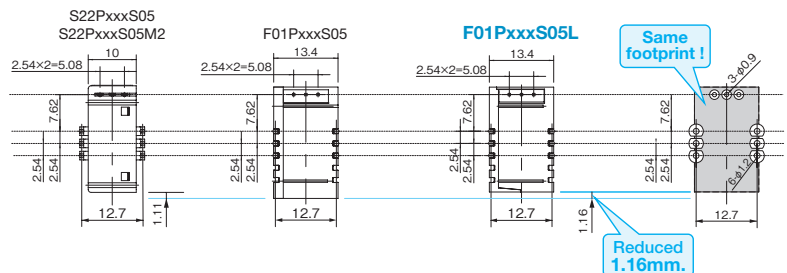

The F02P/F03PxxxS05L series also similarly reduces the mounting area.

The above-mentioned comparison tables are the auxiliary data for understanding each series. For details, please confirm the next page or subsequent ones. >>>

Fluxgate system / Voltage-output type Anti-Surge current, Compact size

F01P L SERIES



ABSOLUTE MAXIMUM RATINGS

Parameters	Symbol	Unit	Value	Comment
Supply voltage	Vcc	V	7	
Primary conductor temperature	—	°C	110	
ESD (HBM: Human Body Model)	—	kV	4	C=100pF, R=1.5k Ω
Maximum peak current	—	kAT	4	Current waveform : • Front time 8μs • Time to half value 20μs • single

ISOLATION CHARACTERISTICS

Parameters	Symbol	Unit	Value	Comment
Insulation voltage	Vd	—	AC4200V, for 1minute (Sensing current 0.5mA)	Primary ↔ Secondary
Insulation Resistance	R _{IS}	—	≥ 500M Ω (at DC500V)	Primary ↔ Secondary
Clearance distance	dCi	—	7.7mm	Primary ↔ Secondary
Creepage distance	dCp	—	7.7mm	Primary ↔ Secondary
Case material	—	—	UL94 V-0	
Comparative Tracking Index : (CTI)	CTI	V	600	
Application example	—	—	300V, CAT III, PD2	Reinforced isolation,non uniform field according to EN62477-1:2012 and EN62477-1:2012/A11:2014, EN61010
	—	—	600V, CAT III, PD2	Basic isolation,non uniform field according to EN62477-1:2012 and EN62477-1:2012/A11:2014, EN61010

ENVIRONMENTAL AND MECHANICAL CHARACTERISTICS

Parameters	Symbol	Unit	Value			Comment
			MIN	TYP	MAX	
Ambient operating temperature	T _A	°C	- 40		+ 105	
Ambient storage temperature	T _S	°C	- 40		+ 105	
Mass	m	g		12		

SPECIFICATIONS

T_A=+25°C, N_p=1T, R_L=10kΩ, V_{cc}=+5V

Parameters	Symbol	Unit	Value			Comment
			MIN	TYP	MAX	
Primary nominal current	F01P006S05L	I _{PN}	A		6	
	F01P015S05L				15	
	F01P025S05L				25	
	F01P050S05L				50	
Primary current, measuring range	F01P006S05L	I _{PM}	A	- 20		20
	F01P015S05L			- 51		51
	F01P025S05L			- 85		85
	F01P050S05L			- 150		150
Supply Voltage	V _{cc}	V		4.75	5.00	5.25
Number of primary turns	N _p	T		1, 2, 3		
Number of secondary turns	F01P006S05L	N _s	T		1816	
	F01P015S05L				1737	
	F01P025S05L				1764	
	F01P050S05L				1600	
Consumption current (at I _p)	F01P006S05L	I _{cc}	mA		25	I _{cc} =15 + I _p (mA) / N _s
	F01P015S05L				30	
	F01P025S05L				35	
	F01P050S05L				55	
Output voltage range	V _o	V		0.375		4.625
Output voltage (at I _p =0A)	V _o	V			2.5	
Electrical offset voltage * 1	F01P006S05L	V _{oe}	mV	- 10.40		10.40
	F01P015S05L			- 7.10		7.10
	F01P025S05L			- 6.25		6.25
	F01P050S05L			- 5.80		5.80
Electrical offset current referred to primary * 1	F01P006S05L	I _{oe}	A	- 0.10		0.10
	F01P015S05L			- 0.17		0.17
	F01P025S05L			- 0.25		0.25
	F01P050S05L			- 0.46		0.46
Temperature coefficient of V _o (at I _p =0A)	F01P006S05L	TCV _o	ppm/K		± 10.0	± 80.0
	F01P015S05L				± 7.5	± 70.0
	F01P025S05L				± 6.5	± 60.0
	F01P050S05L				± 6.0	± 60.0
Theoretical sensitivity	F01P006S05L	G _{th}	mV/A		104.2	625mV/I _{PN}
	F01P015S05L				41.67	
	F01P025S05L				25	
	F01P050S05L				12.5	
Sensitivity error	ε _G	%		- 0.7		0.7
Temperature coefficient of Sensitivity (at T _A = - 40°C~+ 105°C)	TCG	ppm/K				± 40
Linearity error (at I _p)	ε _L	%		- 0.1		0.1
Magnetic offset current referred to primary (at 10 × I _p)	I _{OM}	A		- 0.1		0.1

*1 Offset voltage value is after removal of core hysteresis.

SPECIFICATIONS

T_A=+25°C, N_p=1T, R_L=10kΩ, V_{cc}=+5V

Parameters	Symbol	Unit	Value			Comment	
			MIN	TYP	MAX		
Peak to peak output ripple at oscillator frequency (f typ=450kHz)	F01P006S05L	—	mV		40	160	R _L =1k Ω
	F01P015S05L				15	60	
	F01P025S05L				10	40	
	F01P050S05L				5	20	
Reaction time (at 10% of I _{PN})	F01P006S05L	t _{ra}	μs			0.3	R _L =1k Ω, di/dt=18A/μs
	F01P015S05L					0.3	R _L =1k Ω, di/dt=44A/μs
	F01P025S05L					0.3	R _L =1k Ω, di/dt=68A/μs
	F01P050S05L					0.3	R _L =1k Ω, di/dt=100A/μs
Response time (at 90% of I _{PN})	F01P006S05L	t _r	μs			0.3	R _L =1k Ω, di/dt=18A/μs
	F01P015S05L					0.3	R _L =1k Ω, di/dt=44A/μs
	F01P025S05L					0.3	R _L =1k Ω, di/dt=68A/μs
	F01P050S05L					0.3	R _L =1k Ω, di/dt=100A/μs
Frequency bandwidth (± 1dB)	BW	kHz	200				R _L =1k Ω
Frequency bandwidth (± 3dB)	BW	kHz	300				R _L =1k Ω
Overall Accuracy (at T _A =25°C)	F01P006S05L	X _G	%			2.5	X _G = (100 × V _{oe} /625) + ε _G + ε _L
	F01P015S05L					1.9	
	F01P025S05L					1.8	
	F01P050S05L					1.7	

STANDARDS

EN62477-1 : 2012 and EN62477-1 : 2012/A11 2014, EN61010-1, EN62368-1, UL508 (file No E243511)

※ Please refer to the another sheet about conditions of UL Recognition.

Characteristic curve (TYP)

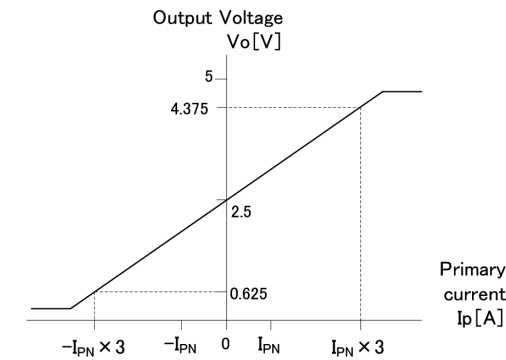

Figure 1 : Linearity curve

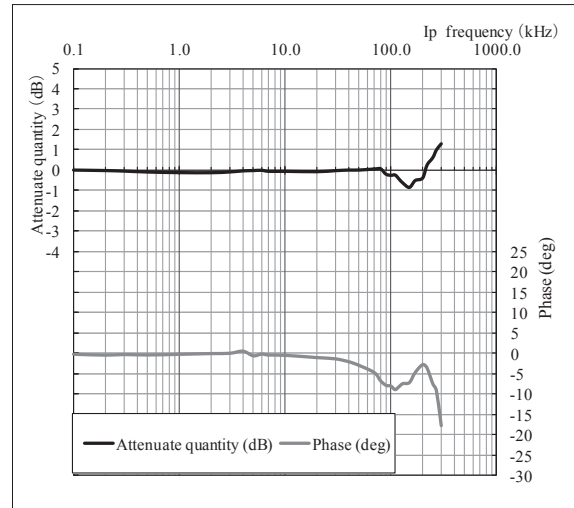

Figure 2 : Frequency response curve

ex) F01P025S05L

Measurement condition T_a=+25°C, R_L=1k Ω, I_p=3A, V_{cc}=+5V

SUPPORT DOCUMENTATION

Maximum continuous DC primary current

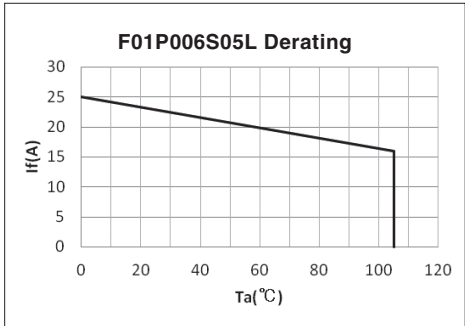

Figure 3 : Ip vs Ta for F01P006S05L

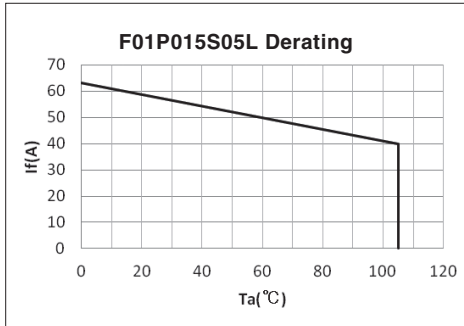

Figure 4 : Ip vs Ta for F01P015S05L

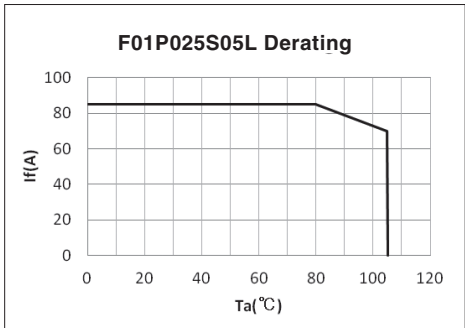

Figure 5 : Ip vs Ta for F01P025S05L

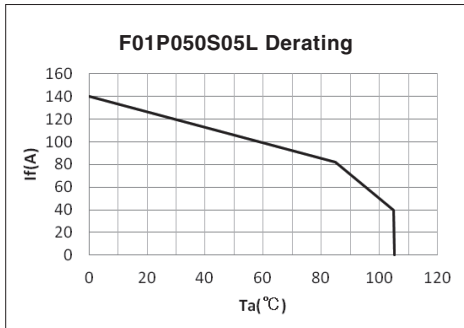

Figure 6 : Ip vs Ta for F01P050S05L

According to which the following conditions are true the maximum continuous DC primary current plot shows the boundary of the area.

- ① $I_p < I_{pmax}$
- ② Junction temperature $T_j < 125^\circ\text{C}$
- ③ Resistor power dissipation $< 0.5 \times \text{rated power}$

Frequency derating

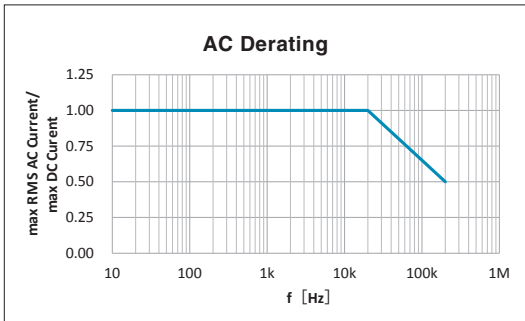
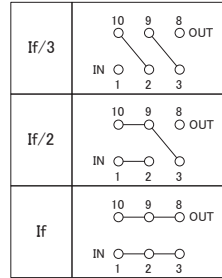
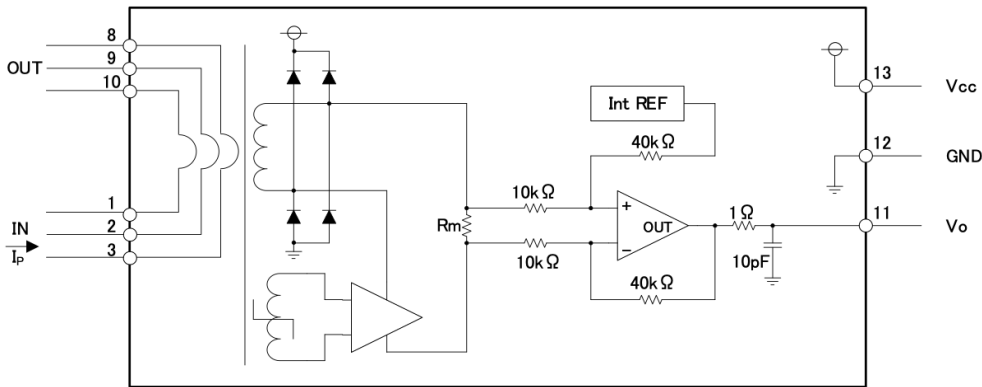
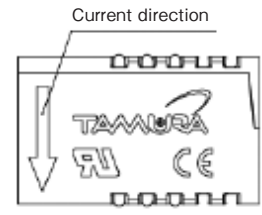
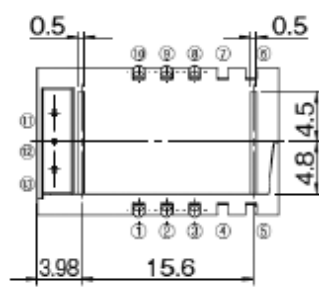
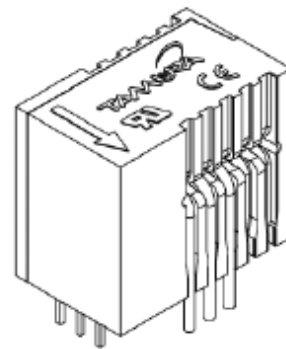
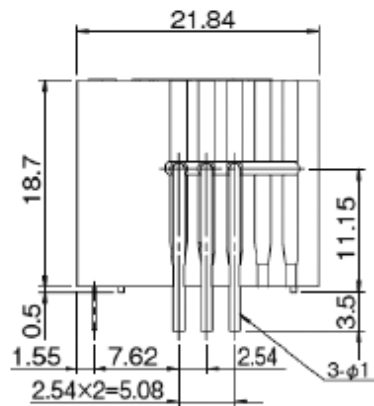
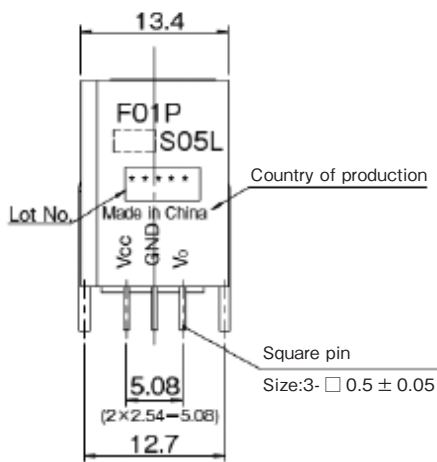

Figure 7 : Maximum RMS AC primary current/maximum DC primary current vs frequency

CURRENT SENSORS



DIMENSIONS (mm)



Terminal number	Note
① Input	1. Unless otherwise specified, tolerances shall be ±0.25mm
② Input	
③ Input	2. Unit is [mm]
④ —	
⑤ —	⑪ Vo
⑥ —	⑫ GND
⑦ —	⑬ Vcc

RECOMMENDED HOLE DIAMETER (mm)

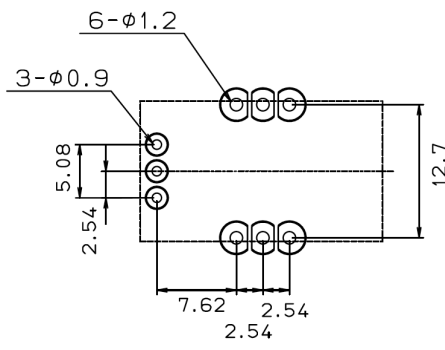

Identification marking

The top side of product is marked for identification with the previous model.

- Rated current 6A ... Blue color
- Rated current 15A ... White color
- Rated current 25A ... Orange color
- Rated current 50A ... Green color

Ex) Marking example

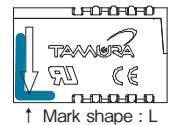

↑ Mark shape : L

Fluxgate system / Voltage-output type Anti-Surge current, Compact size

F02P L SERIES

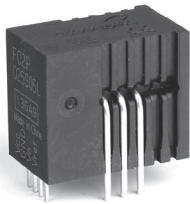

ABSOLUTE MAXIMUM RATINGS

Parameters	Symbol	Unit	Value	Comment
Supply voltage	Vcc	V	7	
Primary conductor temperature	—	°C	110	
ESD (HBM: Human Body Model)	—	kV	4	C=100pF, R=1.5k Ω
Maximum peak current	—	kAT	4	Current waveform : • Front time 8μs • Time to half value 20μs • single

ISOLATION CHARACTERISTICS

Parameters	Symbol	Unit	Value	Comment
Insulation voltage	Vd	—	AC4100V, for 1minute (Sensing current 0.5mA)	Primary ↔ Secondary
Insulation Resistance	R _{IS}	—	≥ 500M Ω (at DC500V)	Primary ↔ Secondary
Clearance distance	d _{ci}	—	7.5mm	Primary ↔ Secondary
Creepage distance	d _{cp}	—	7.5mm	Primary ↔ Secondary
Case material	—	—	UL94 V-0	
Comparative Tracking Index: (CTI)	CTI	V	600	
Application example	—	—	300V, CAT III, PD2	Reinforced isolation, non uniform field according to EN62477-1:2012 and EN62477-1:2012/A11:2014, EN61010
	—	—	600V, CAT III, PD2	Basic isolation, non uniform field according to EN62477-1:2012 and EN62477-1:2012/A11:2014, EN61010

ENVIRONMENTAL AND MECHANICAL CHARACTERISTICS

Parameters	Symbol	Unit	Value			Comment
			MIN	TYP	MAX	
Ambient operating temperature	T _A	°C	- 40		+ 105	
Ambient storage temperature	T _S	°C	- 40		+ 105	
Mass	m	g		12		

SPECIFICATIONS

T_A=+25°C, N_p=1T, R_L=10kΩ, V_{cc}=+5V

Parameters	Symbol	Unit	Value			Comment
			MIN	TYP	MAX	
Primary nominal current	F02P006S05L	I _{PN}	A		6	
	F02P015S05L				15	
	F02P025S05L				25	
	F02P050S05L				50	
Primary current, measuring range	F02P006S05L	I _{PM}	A	- 20		20
	F02P015S05L			- 51		51
	F02P025S05L			- 85		85
	F02P050S05L			- 150		150
Supply Voltage	V _{cc}	V	4.75	5.00	5.25	
Number of primary turns	N _p	T	1, 2, 3			
Number of secondary turns	F02P006S05L	N _s	T		1816	
	F02P015S05L				1737	
	F02P025S05L				1764	
	F02P050S05L				1600	
Consumption current ((at I _p)	F02P006S05L	I _{cc}	mA		25	I _{cc} =15 + I _p (mA) / N _s
	F02P015S05L				30	
	F02P025S05L				35	
	F02P050S05L				55	
Reference voltage (output) (at I _p =0A)	V _{ref1}	V	2.495	2.500	2.505	Ref OUT mode
Reference voltage (input)	V _{ref2}	V	0		4	Ref IN mode
Output voltage range	V _o	V	0.375		4.625	
Output voltage (at I _p =0A)	V _o	V		V _{ref1} , V _{ref2}		
Electrical offset voltage * 1	F02P006S05L	V _{oe}	mV	- 5.300		5.300
	F02P015S05L			- 2.210		2.210
	F02P025S05L			- 1.350		1.350
	F02P050S05L			- 0.725		0.725
Electrical offset current referred to primary * 1	F02P006S05L	I _{oe}	mA	- 51		51
	F02P015S05L			- 53		53
	F02P025S05L			- 54		54
	F02P050S05L			- 58		58
Temperature coefficient of V _{ref1}	TCV _{ref1}	ppm/K		± 5.0	± 50	
Temperature coefficient of V _o (at I _p =0A)	F02P006S05L	TCV _o	ppm/K		± 6.0	± 14
	F02P015S05L				± 2.3	± 6
	F02P025S05L				± 1.4	± 4
	F02P050S05L				± 0.7	± 3
Theoretical sensitivity	F02P006S05L	G _{th}	mV/A		104.2	625mV/I _{PN}
	F02P015S05L				41.67	
	F02P025S05L				25	
	F02P050S05L				12.5	
Sensitivity error	ε _G	%	- 0.7		0.7	
Temperature coefficient of Sensitivity (at T _A = - 40°C~+ 105°C)	TCG	ppm/K			± 40	
Linearity error (at I _p)	ε _L	%	- 0.1		0.1	
Magnetic offset current referred to primary (at 10 × I _p)	I _{OM}	A	- 0.1		0.1	

*1 Offset voltage value is after removal of core hysteresis.

SPECIFICATIONS

T_A=+25°C, N_p=1T, R_L=10kΩ, V_{cc}=+5V

Parameters	Symbol	Unit	Value			Comment	
			MIN	TYP	MAX		
Peak to peak output ripple at oscillator frequency (f typ=450kHz)	F02P006S05L	—	mV		40	160	R _L =1kΩ
	F02P015S05L				15	60	
	F02P025S05L				10	40	
	F02P050S05L				5	20	
Reaction time (at 10% of I _{PN})	F02P006S05L	t _{ra}	μs			0.3	R _L =1kΩ, di/dt=18A/μs
	F02P015S05L					0.3	R _L =1kΩ, di/dt=44A/μs
	F02P025S05L					0.3	R _L =1kΩ, di/dt=68A/μs
	F02P050S05L					0.3	R _L =1kΩ, di/dt=100A/μs
Response time 1 (at 90% of I _{PN})	F02P006S05L	t _r	μs			0.3	R _L =1kΩ, di/dt=18A/μs
	F02P015S05L					0.3	R _L =1kΩ, di/dt=44A/μs
	F02P025S05L					0.3	R _L =1kΩ, di/dt=68A/μs
	F02P050S05L					0.3	R _L =1kΩ, di/dt=100A/μs
Frequency bandwidth (± 1dB)	BW	kHz	200				R _L =1kΩ
Frequency bandwidth (± 3dB)	BW	kHz	300				R _L =1kΩ
Overall Accuracy (at T _A =25°C)	F02P006S05L	X _G	%			1.7	X _G = (100 × V _{oe} /625) + ε _G + ε _L
	F02P015S05L					1.2	
	F02P025S05L					1.0	
	F02P050S05L					0.9	

STANDARDS

EN62477-1 : 2012 and EN62477-1 : 2012/A11 2014, EN61010-1, EN62368-1, UL508 (file No E243511)

※ Please refer to the another sheet about conditions of UL Recognition.

Characteristic curve (TYP)

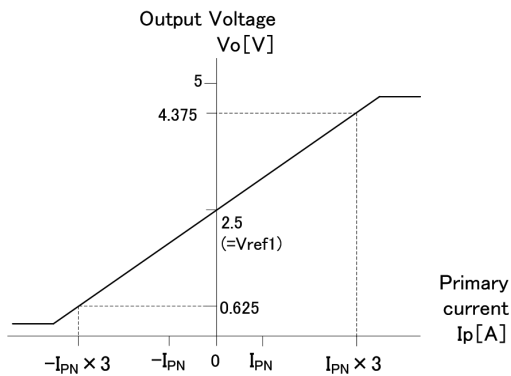

Figure 1 : Linearity curve (Internal reference voltage)

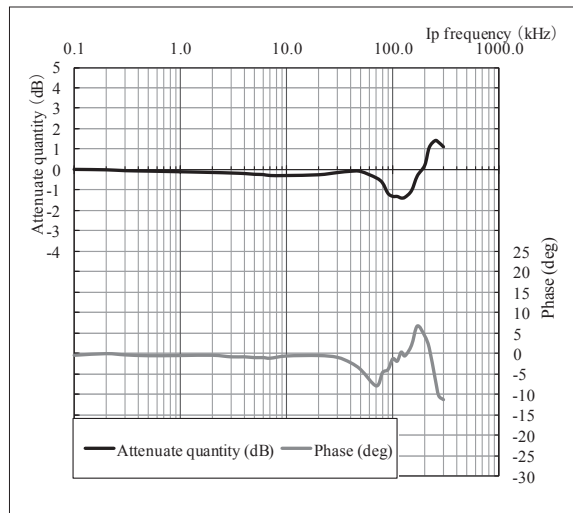

Figure 2 : Frequency response curve
ex) F02P025S05L
Measurement condition T_a=+25°C, R_L=1kΩ, I_p=3A, V_{cc}=+5V

SUPPORT DOCUMENTATION

Maximum continuous DC primary current

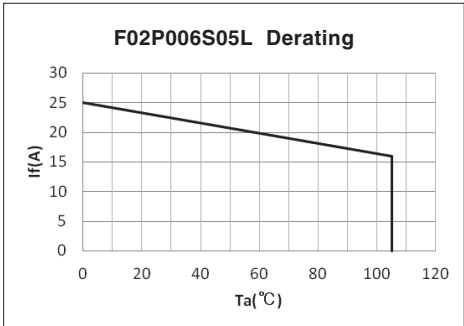

Figure 3 : Ip vs Ta for F02P006S05L

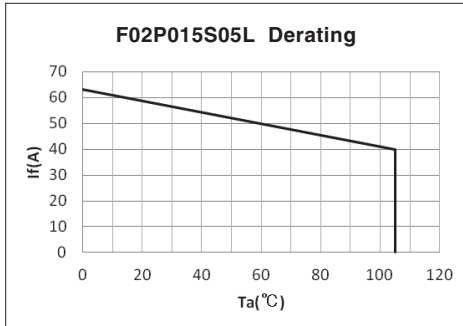

Figure 4 : Ip vs Ta for F02P015S05L

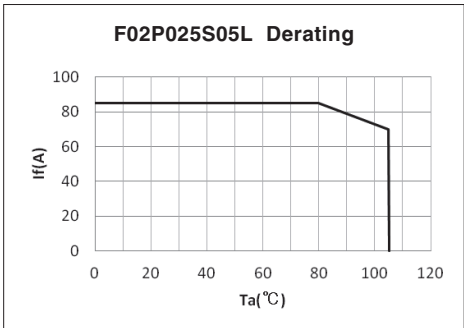

Figure 5 : Ip vs Ta for F02P025S05L

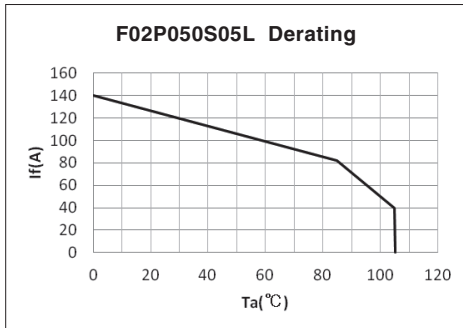

Figure 6 : Ip vs Ta for F02P050S05L

According to which the following conditions are true the maximum continuous DC primary current plot shows the boundary of the area.

- ① $I_p < I_{pmax}$
- ② Junction temperature $T_j < 125^\circ\text{C}$
- ③ Resistor power dissipation $< 0.5 \times \text{rated power}$

Frequency derating

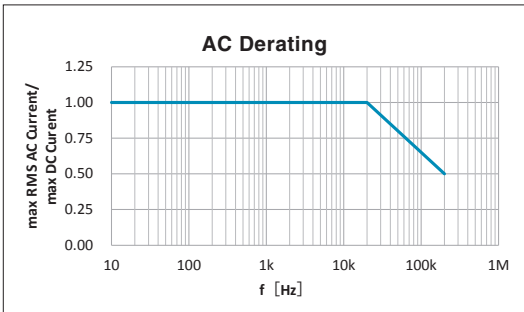

Figure 7 : Maximum RMS AC primary current/maximum DC primary current vs frequency

Reference voltage

The Ref pin has two modes Ref IN and Ref OUT :

< Ref OUT mode >

The 2.5V internal precision reference is used by the transducer as the reference point for bipolar measurements;

< Ref IN mode >

An external reference voltage is connected to the Ref pin; this voltage is specified in the range 0 to 4 V , its voltage is used as the reference voltage at the time of measurement.

- either to source a typical current of $(V_{ref} - 2.5) / 680$, the maximum value will be 2.2mA typ. when $V_{ref2} = 4V$.
- or to sink a typical current of $(2.5 - V_{ref2}) / 680$, the maximum value will be 3.68mA typ. when $V_{ref2} = 0V$.

The following graphs show how the measuring range of each transducer version depends on external reference voltage value V_{ref2} .

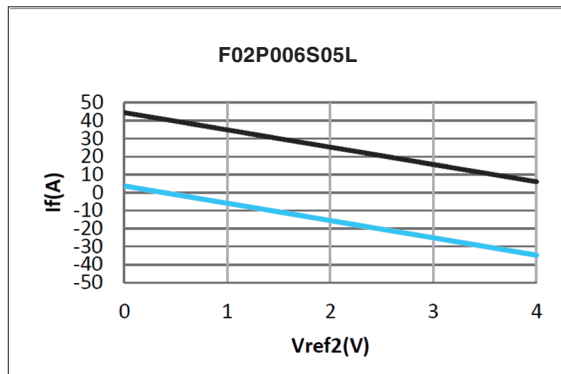

Upper limit : $I_p = -9.6 \times V_{ref2} + 44.4$ ($V_{ref2} = 0...4V$)
 Lower limit : $I_p = -9.6 \times V_{ref2} + 3.6$ ($V_{ref2} = 0...4V$)

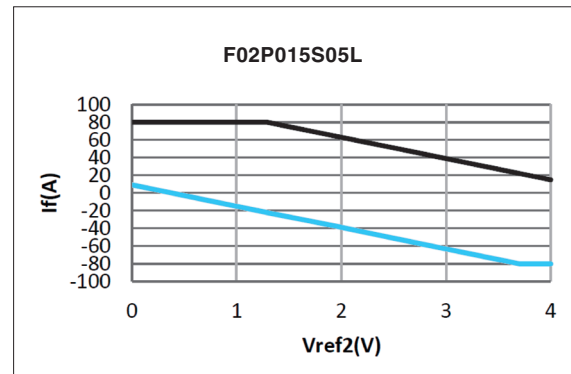

Upper limit : $I_p = 80$ ($V_{ref2} = 0...1.29V$)
 $I_p = -24 \times V_{ref2} + 111$ ($V_{ref2} = 1.29...4V$)
 Lower limit : $I_p = -24 \times V_{ref2} + 9$ ($V_{ref2} = 0...3.7V$)
 $I_p = -80$ ($V_{ref2} = 3.7...4V$)

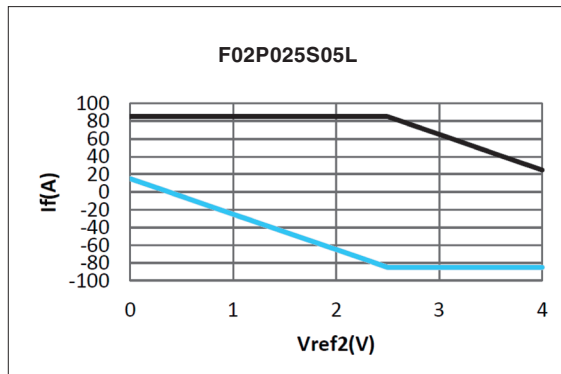

Upper limit : $I_p = 85$ ($V_{ref2} = 0...2.5V$)
 $I_p = -40 \times V_{ref2} + 185$ ($V_{ref2} = 2.5...4V$)
 Lower limit : $I_p = -40 \times V_{ref2} + 15$ ($V_{ref2} = 0...2.5V$)
 $I_p = -85$ ($V_{ref2} = 2.5...4V$)

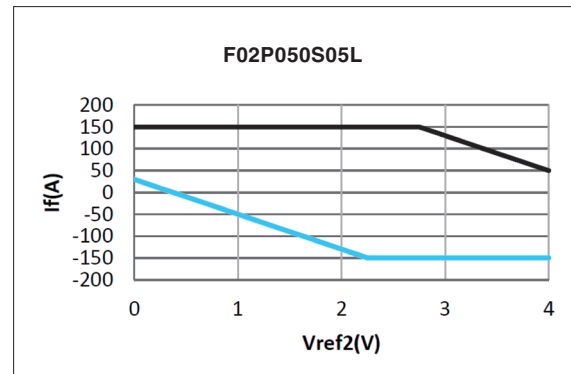

Upper limit : $I_p = 150$ ($V_{ref2} = 0...2.75V$)
 $I_p = -80 \times V_{ref2} + 370$ ($V_{ref2} = 2.75...4V$)
 Lower limit : $I_p = -80 \times V_{ref2} + 30$ ($V_{ref2} = 0...2.25V$)
 $I_p = -150$ ($V_{ref2} = 2.25...4V$)

If you do not want to use the Ref pin, please unconnected.

CONNECTION

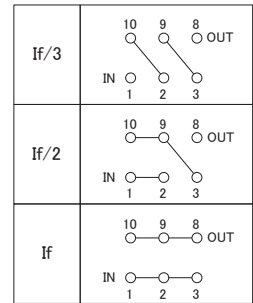
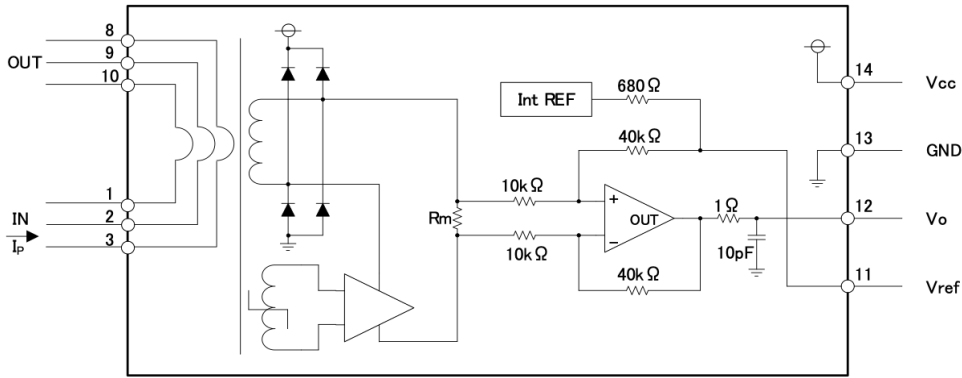

DIMENSIONS (mm)

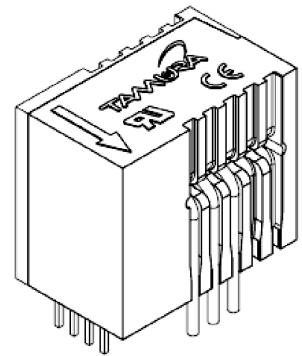
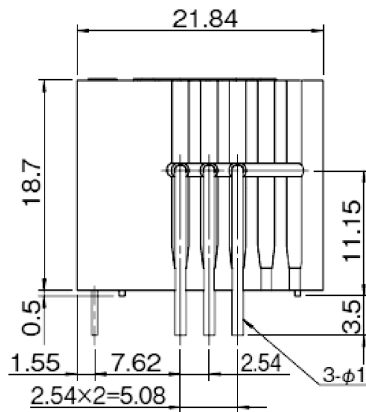
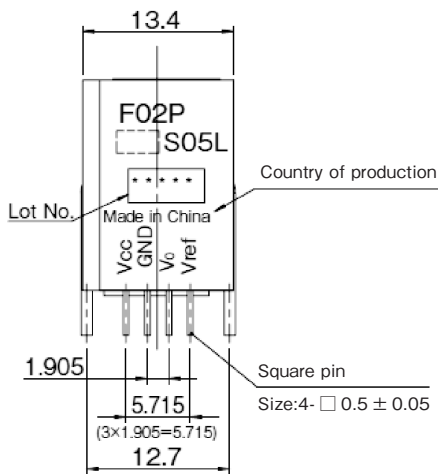

Terminal number	Note
① Input	1. Unless otherwise specified, tolerances shall be ± 0.25 mm
⑧ Output	
② Input	2. Unit is [mm]
⑨ Output	
③ Input	
⑩ Output	
④ —	
⑪ Vref	
⑤ —	
⑫ V _o	
⑥ —	
⑬ GND	
⑦ —	
⑭ Vcc	

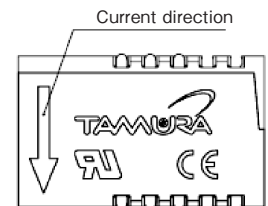
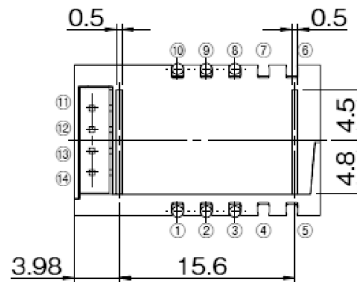

RECOMMENDED HOLE DIAMETER (mm)

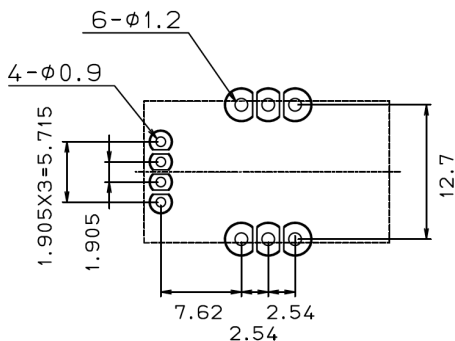

Identification marking

The top side of product is marked for identification with the previous model.

- Rated current 6A ... Blue color
- Rated current 15A ... White color
- Rated current 25A ... Orange color
- Rated current 50A ... Green color

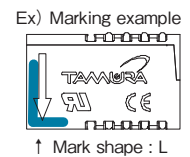

Fluxgate system / Voltage-output type Anti-Surge current, Compact size

F03P L SERIES

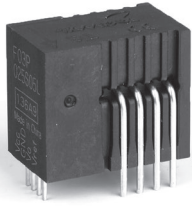

ABSOLUTE MAXIMUM RATINGS

Parameters	Symbol	Unit	Value	Comment
Supply voltage	Vcc	V	7	
Primary conductor temperature	—	°C	110	
ESD (HBM: Human Body Model)	—	kV	4	C=100pF, R=1.5k Ω
Maximum peak current	—	kAT	4	Current waveform : • Front time 8μs • Time to half value 20μs • single

ISOLATION CHARACTERISTICS

Parameters	Symbol	Unit	Value	Comment
Insulation voltage	Vd	—	AC4300V, for 1minute (Sensing current 0.5mA)	Primary ↔ Secondary
Insulation Resistance	R _{IS}	—	≥ 500M Ω (at DC500V)	Primary ↔ Secondary
Clearance distance	d _{ci}	—	8.2mm	Primary ↔ Secondary
Creepage distance	dCp	—	8.2mm	Primary ↔ Secondary
Case material	—	—	UL94 V-0	
Comparative Tracking Index : (CTI)	CTI	V	600	
Application example	—	—	300V, CAT III, PD2	Reinforced isolation, non uniform field according to EN61010
	—	—	600V, CAT III, PD2	Reinforced isolation, non uniform field according to EN62477-1:2012 and EN62477-1:2012/A11:2014.
	—	—	1000V, CAT III, PD2	Basic isolation, non uniform field according to EN62477-1:2012 and EN62477-1:2012/A11:2014.

ENVIRONMENTAL AND MECHANICAL CHARACTERISTICS

Parameters	Symbol	Unit	Value			Comment
			MIN	TYP	MAX	
Ambient operating temperature	T _A	°C	- 40		+ 105	
Ambient storage temperature	T _S	°C	- 40		+ 105	
Mass	m	g		12		

SPECIFICATIONS

T_A=+25°C, N_p=1T, R_L=10kΩ, V_{cc}=+5V

Parameters	Symbol	Unit	Value			Comment
			MIN	TYP	MAX	
Primary nominal current	F03P006S05L	I _{PN}	A		6	
	F03P015S05L				15	
	F03P025S05L				25	
	F03P050S05L				50	
Primary current, measuring range	F03P006S05L	I _{PM}	A	- 20		20
	F03P015S05L			- 51		51
	F03P025S05L			- 85		85
	F03P050S05L			- 150		150
Supply Voltage	V _{cc}	V	4.75	5.00	5.25	
Number of primary turns	N _p	T	1, 2, 3, 4			
Number of secondary turns	F03P006S05L	N _s	T		1816	
	F03P015S05L				1737	
	F03P025S05L				1764	
	F03P050S05L				1600	
Consumption current ((at I _p)	F03P006S05L	I _{cc}	mA		25	I _{cc} = 15 + I _p (mA) / N _s
	F03P015S05L				30	
	F03P025S05L				35	
	F03P050S05L				55	
Reference voltage (output) (at I _p =0A)	V _{ref1}	V	2.495	2.500	2.505	Ref OUT mode
Reference voltage (input)	V _{ref2}	V	0		4	Ref IN mode
Output voltage range	V _o	V	0.375		4.625	
Output voltage (at I _p =0A)	V _o	V		V _{ref1} , V _{ref2}		
Electrical offset voltage * 1	F03P006S05L	V _{oe}	mV	- 5.300		5.300
	F03P015S05L			- 2.210		2.210
	F03P025S05L			- 1.350		1.350
	F03P050S05L			- 0.725		0.725
Electrical offset current referred to primary * 1	F03P006S05L	I _{oe}	mA	- 51		51
	F03P015S05L			- 53		53
	F03P025S05L			- 54		54
	F03P050S05L			- 58		58
Temperature coefficient of V _{ref1}	TCV _{ref1}	ppm/K		± 5.0	± 50	
Temperature coefficient of V _o (at I _p =0A)	F03P006S05L	TCV _o	ppm/K		± 6.0	± 14
	F03P015S05L				± 2.3	± 6
	F03P025S05L				± 1.4	± 4
	F03P050S05L				± 0.7	± 3
Theoretical sensitivity	F03P006S05L	G _{th}	mV/A		104.2	625mV/I _{PN}
	F03P015S05L				41.67	
	F03P025S05L				25	
	F03P050S05L				12.5	
Sensitivity error	ε _G	%	- 0.7		0.7	
Temperature coefficient of Sensitivity (at T _A = - 40°C ~ + 105°C)	TCG	ppm/K			± 40	
Linearity error (at I _p)	ε _L	%	- 0.1		0.1	
Magnetic offset current referred to primary (at 10 × I _p)	I _{OM}	A	- 0.1		0.1	

*1 Offset voltage value is after removal of core hysteresis.

SPECIFICATIONS

T_A=+25°C, N_p=1T, R_L=10kΩ, V_{cc}=+5V

Parameters	Symbol	Unit	Value			Comment	
			MIN	TYP	MAX		
Peak to peak output ripple at oscillator frequency (f typ = 450kHz)	F03P006S05L	—	mV		40	160	R _L = 1k Ω
	F03P015S05L				15	60	
	F03P025S05L				10	40	
	F03P050S05L				5	20	
Reaction time (at 10% of I _{PN})	F03P006S05L	t _{ra}	μs			0.3	R _L = 1k Ω, di/dt = 18A/μs
	F03P015S05L					0.3	R _L = 1k Ω, di/dt = 44A/μs
	F03P025S05L					0.3	R _L = 1k Ω, di/dt = 68A/μs
	F03P050S05L					0.3	R _L = 1k Ω, di/dt = 100A/μs
Response time (at 90% of I _{PN})	F03P006S05L	tr	μs			0.3	R _L = 1k Ω, di/dt = 18A/μs
	F03P015S05L					0.3	R _L = 1k Ω, di/dt = 44A/μs
	F03P025S05L					0.3	R _L = 1k Ω, di/dt = 68A/μs
	F03P050S05L					0.3	R _L = 1k Ω, di/dt = 100A/μs
Frequency bandwidth (± 1dB)	BW	kHz	200			R _L = 1k Ω	
Frequency bandwidth (± 3dB)	BW	kHz	300			R _L = 1k Ω	
Overall Accuracy (at T _A =25°C)	F03P006S05L	X _G	%			1.7	X _G = (100 × V _{oe} /625) + ε _G + ε _L
	F03P015S05L					1.2	
	F03P025S05L					1.0	
	F03P050S05L					0.9	

STANDARDS

EN62477-1 : 2012 and EN62477-1 : 2012/A11 2014, EN61010-1, EN62368-1, UL508 (file No. E243511)

※ Please refer to the another sheet about conditions of UL Recognition.

Characteristic curve (TYP)

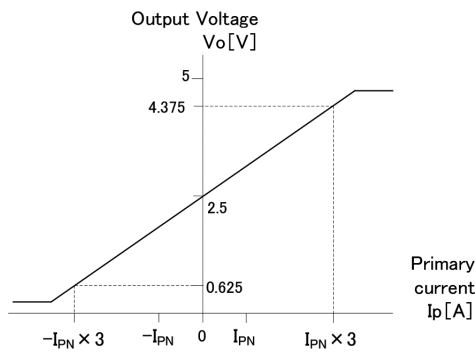

Figure 1 : Linearity curve (Internal reference voltage)

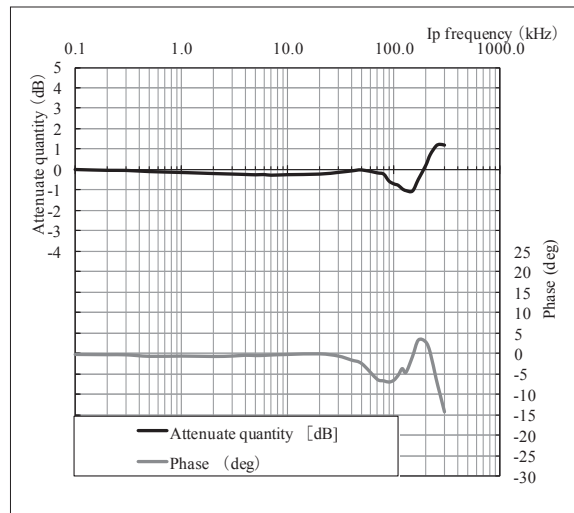

Figure 2 : Frequency response curve

ex) F03P025S05L

Measurement condition T_a=+25°C, R_L=1k Ω, I_p=3A, V_{cc}=+5V

SUPPORT DOCUMENTATION

Maximum continuous DC primary current

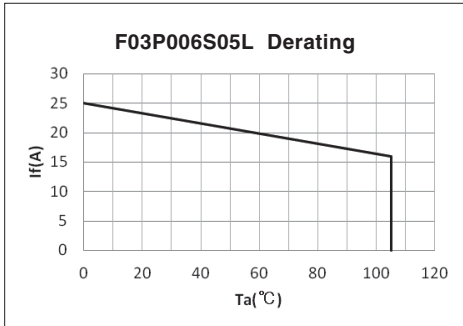

Figure 3 : Ip vs Ta for F03P006S05L

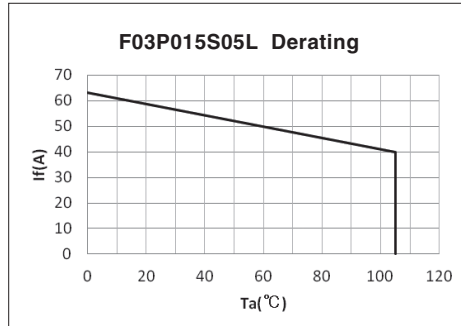

Figure 4 : Ip vs Ta for F03P015S05L

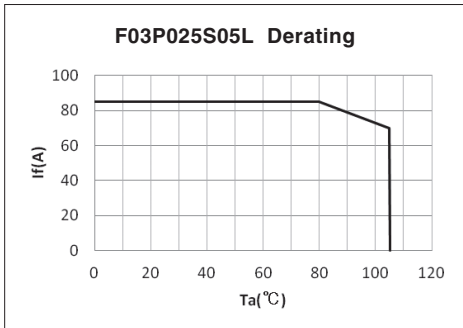

Figure 5 : Ip vs Ta for F03P025S05L

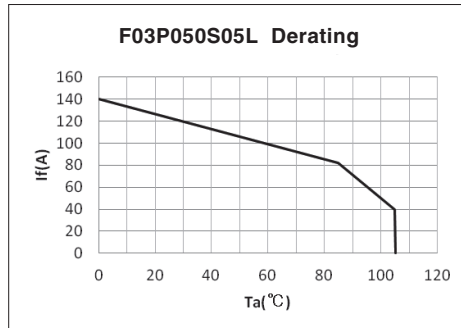

Figure 6 : Ip vs Ta for F03P050S05L

According to which the following conditions are true the maximum continuous DC primary current plot shows the boundary of the area.

- ① $I_p < I_{pmax}$
- ② Junction temperature $T_j < 125^\circ\text{C}$
- ③ Resistor power dissipation $< 0.5 \times \text{rated power}$

Frequency derating

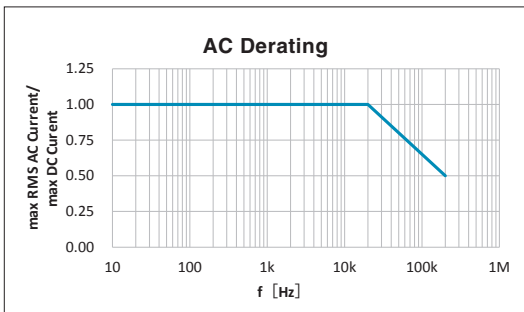

Figure 7 : Maximum RMS AC primary current/maximum DC primary current vs frequency

Reference voltage

The Ref pin has two modes Ref IN and Ref OUT :

< Ref OUT mode >

The 2.5V internal precision reference is used by the transducer as the reference point for bipolar measurements;

< Ref IN mode >

An external reference voltage is connected to the Ref pin; this voltage is specified in the range 0 to 4 V, its voltage is used as the reference voltage at the time of measurement.

- either to source a typical current of $(V_{ref} - 2.5) / 680$, the maximum value will be 2.2mA typ. when $V_{ref2} = 4V$.
- or to sink a typical current of $(2.5 - V_{ref2}) / 680$, the maximum value will be 3.68mA typ. when $V_{ref2} = 0V$.

The following graphs show how the measuring range of each transducer version depends on external reference voltage value V_{ref2} .

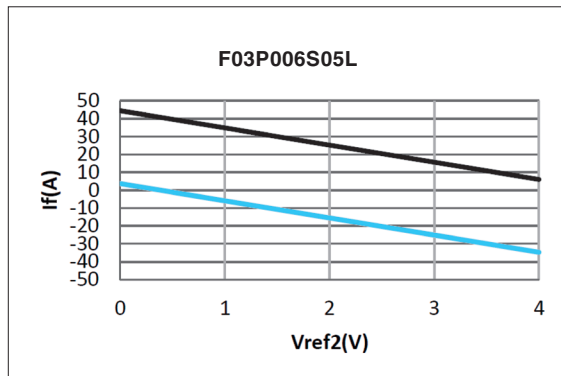

Upper limit : $I_p = -9.6 \times V_{ref2} + 44.4$ ($V_{ref2} = 0...4V$)
 Lower limit : $I_p = -9.6 \times V_{ref2} + 3.6$ ($V_{ref2} = 0...4V$)

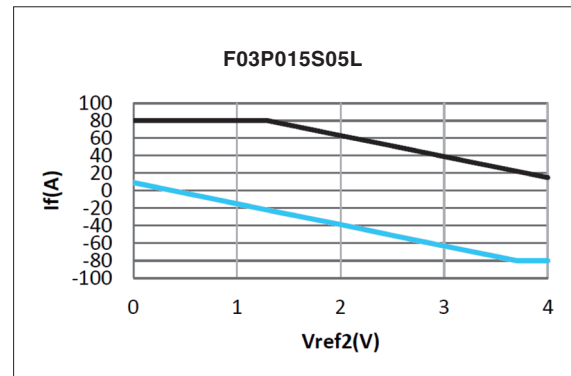

Upper limit : $I_p = 80$ ($V_{ref2} = 0...1.29V$)
 $I_p = -24 \times V_{ref2} + 111$ ($V_{ref2} = 1.29...4V$)
 Lower limit : $I_p = -24 \times V_{ref2} + 9$ ($V_{ref2} = 0...3.7V$)
 $I_p = -80$ ($V_{ref2} = 3.7...4V$)

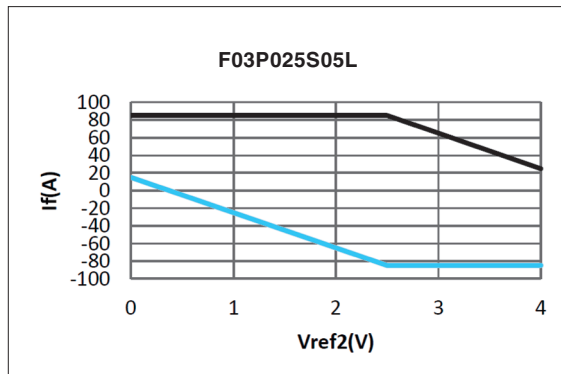

Upper limit : $I_p = 85$ ($V_{ref2} = 0...2.5V$)
 $I_p = -40 \times V_{ref2} + 185$ ($V_{ref2} = 2.5...4V$)
 Lower limit : $I_p = -40 \times V_{ref2} + 15$ ($V_{ref2} = 0...2.5V$)
 $I_p = -85$ ($V_{ref2} = 2.5...4V$)

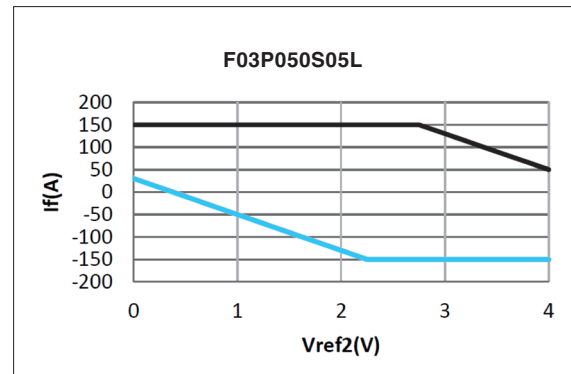

Upper limit : $I_p = 150$ ($V_{ref2} = 0...2.75V$)
 $I_p = -80 \times V_{ref2} + 370$ ($V_{ref2} = 2.75...4V$)
 Lower limit : $I_p = -80 \times V_{ref2} + 30$ ($V_{ref2} = 0...2.25V$)
 $I_p = -150$ ($V_{ref2} = 2.25...4V$)

If you do not want to use the Ref pin, please unconnected.

CONNECTION

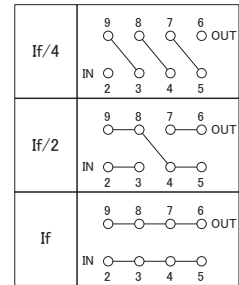
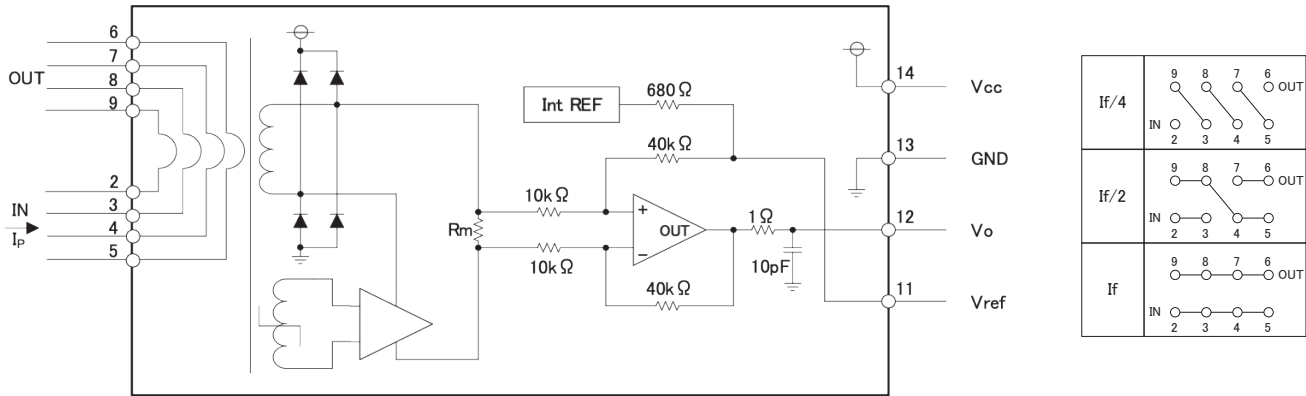

DIMENSIONS (mm)

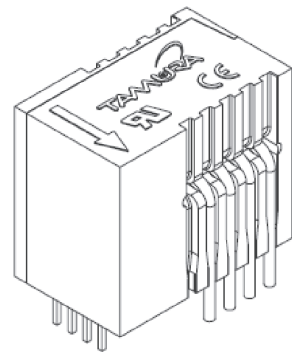
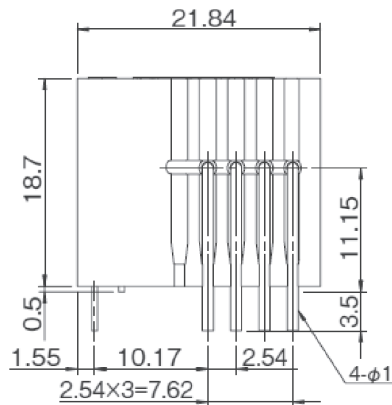
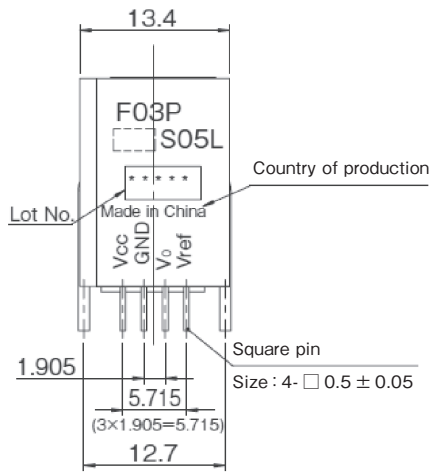

Terminal number	
①	—
②	Input
③	Input
④	Input
⑤	Input
⑥	Output
⑦	Output
⑧	Output
⑨	Output
⑩	—
⑪	Vref
⑫	Vo
⑬	GND
⑭	Vcc

Note
 1. Unless otherwise specified, tolerances shall be ±0.25mm
 2. Unit is [mm]

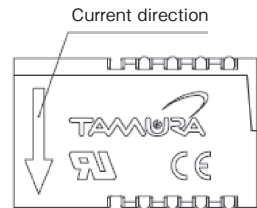
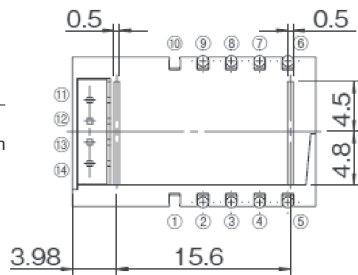

RECOMMENDED HOLE DIAMETER (mm)

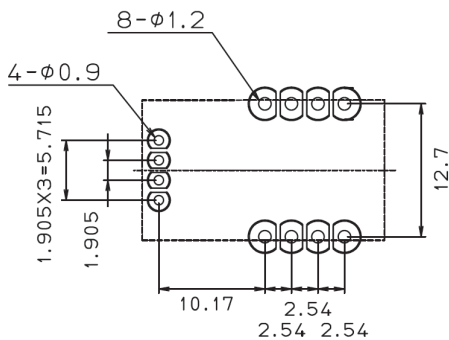

Identification marking

The top side of product is marked for identification with the previous model.

- Rated current 6A ··· Blue color
- Rated current 15A ··· White color
- Rated current 25A ··· Orange color
- Rated current 50A ··· Green color

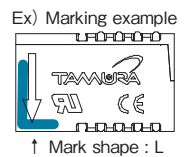

Fluxgate system / Voltage-output type

F23PxxxS05R SERIES



[STANDARDS]
 •UL508
 •CSA C22.2 No.14-18
 •EN 62477-1
 •IEC61800-5-1



ABSOLUTE MAXIMUM RATINGS

Parameters	Symbol	Unit	Value	Comment
Supply voltage	V _{CC}	V	7	
Primary conductor temperature	—	°C	110	
ESD (HBM: Human Body Model)	—	kV	4	C=150pF, R=330 Ω

ISOLATION CHARACTERISTICS

Parameters	Symbol	Unit	Value	Comment
Insulation voltage	V _d	—	AC5000V, for 1minute (Sensing current 0.5mA)	Primary ⇄ Secondary
Insulation Resistance	R _{IS}	—	≥ 500M Ω (at DC500V)	Primary ⇄ Secondary
Clearance distance	d _{Cl}	—	11.0mm (MIN)	Primary ⇄ Secondary
Creepage distance	d _{Cp}	—	12.7mm (MIN)	Primary ⇄ Secondary
Case material	—	—	UL94 V-0	
Comparative Tracking Index : (CTI)	CTI	V	600	

ENVIRONMENTAL AND MECHANICAL CHARACTERISTICS

Parameters	Symbol	Unit	Value			Comment
			MIN	TYP	MAX	
Ambient operating temperature	T _A	°C	- 40		+ 85	
Ambient storage temperature	T _S	°C	- 40		+ 85	
Mass	m	g		13		

SPECIFICATIONS

T_a=+25°C, N_p=1T, R_L=10kΩ, V_{CC}=+5V

Parameters	Symbol	Unit	Value			Comment
			MIN	TYP	MAX	
Primary nominal current	F23P050S05R	I _{PN}	A		50	
	F23P100S05R				100	
Primary current, measuring range	F23P050S05R	I _{PM}	A	- 150		+ 150
	F23P100S05R			- 200		+ 200
Supply Voltage	V _{CC}	V	4.75	5.00	5.25	
Number of primary turns	N _p	T	1, 2, 3			
Number of secondary turns	F23P050S05R	N _s	T		1441	
	F23P100S05R				1127	
Consumption current	F23P050S05R	I _{CC}	mA		55	
	F23P100S05R				110	

I_{CC} = 20 + I_{PN} / N_s + V_{out} / R_L

SPECIFICATIONS

Ta=+25°C ,Np=1T, RL=10kΩ, Vcc=+5V

Parameters	Symbol	Unit	Value			Comment	
			MIN	TYP	MAX		
Reference voltage (output)	Vref1	V	2.495	2.500	2.505	Ref OUT mode. at Ip=0A	
Reference voltage (input)	Vref2	V	0		4	Ref IN mode	
Output voltage	Vo	V		Vref1, Vref2		at Ip=0A	
Electrical offset voltage * 1	F23P050S05R	Voe	mV	- 2.5	2.5		
	F23P100S05R						
Electrical offset current referred to primary	F23P050S05R	loe	mA	- 200	200		
	F23P100S05R						- 400
Temperature coefficient of Vref1	TCVref1	ppm/K		± 5.0	± 50		
Temperature coefficient of Vo	F23P050S05R	TCVo	ppm/K		± 3.0	± 10	ppm/K of 2.5V. at Ip=0A, Ta : -40°C~ +85°C.
	F23P100S05R						
Theoretical sensitivity	F23P050S05R	Gth	mV/A		12.5		625mV (at IPN) = Vref - Vout / IPN
	F23P100S05R						
Sensitivity error	εG	%	- 0.7		0.7		
Temperature coefficient of Sensitivity	TCG	ppm/K			± 40	Ta=-40°C~ +85°C	
Linearity error	εL	%	- 0.1		0.1	at Ip = 0A ~ IPN	
External recommended resistance of Vout	RL	kΩ		10			
External recommended capacitance of Vout	CL	pF			500		
Peak to peak output ripple at oscillator frequency	F23P050S05R	—	mV		5	20	RL=1kΩ, f_typ =450kHz
	F23P100S05R						
Reaction time (at 10% of IPN)	F23P050S05R	t _{ra}	μs			0.5	RL=1kΩ, di/dt = Ipn or 100A/μs. Whichever is smaller.
	F23P100S05R						
Response time (at 90% of IPN)	F23P050S05R	tr	μs			0.5	RL=1kΩ, di/dt = Ipn or 100A/μs. Whichever is smaller.
	F23P100S05R						
Frequency bandwidth (± 3dB)	BW	kHz		100		RL=1kΩ	
Overall Accuracy (at Ta=25°C)	F23P050S05R	X _G	%			1.2	X _G = (100× Voe/625) + ε _G +ε _L
	F23P100S05R						

*1 Offset voltage value is after removal of core hysteresis.

STANDARDS



EN62477-1:2012, EN62477-1:2012/A1:2017 and EN62477-1:2012/A11:2014
Rated voltage 600V, CAT III, PD2, Reinforced isolation, non uniform field

IEC61800-5-1

Rated voltage 600V, CAT III, PD2, Reinforced isolation, non uniform field



UL508, CSA C22.2 No.14-18 (CSA FILE No. E243511)

Rated voltage 600V, PD2

※ Please refer to the another sheet about conditions of UL Recognition.

Characteristic curve (TYP)

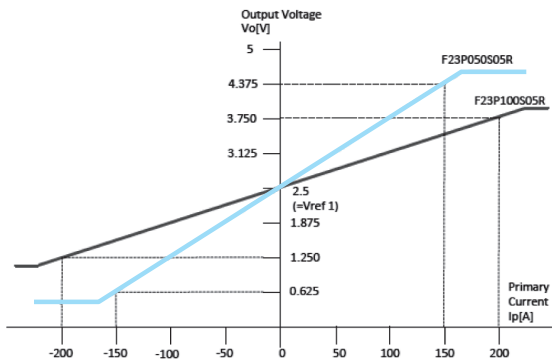

Figure 1 : Linearity curve (Internal reference voltage)
Measurement condition Ta=+25°C, RL=10kΩ, Vcc=+5V

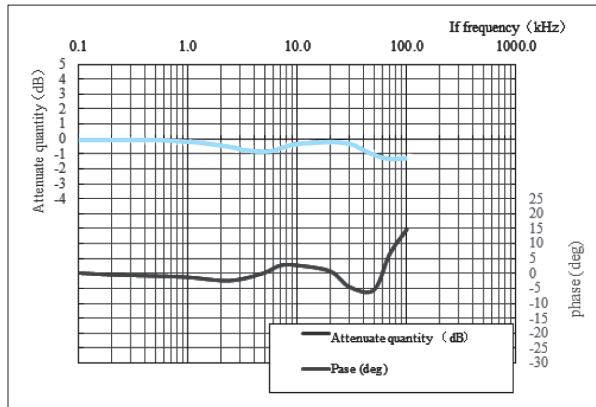

Figure 2 : Frequency response curve
ex) F23P100S05R
Measurement condition Ta=+25°C, RL=1kΩ, Ip=3A × 3T, Vcc=+5V

SUPPORT DOCUMENTATION

Maximum continuous DC primary current

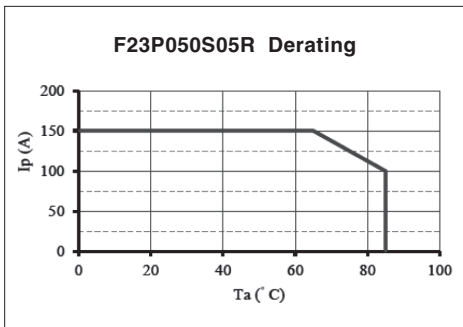

Figure 3 : Ip vs Ta for F23P050S05R

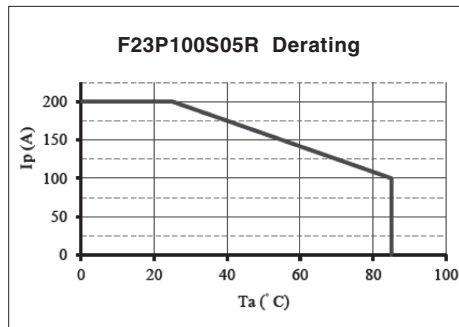

Figure 4 : Ip vs Ta for F23P100S05R
Measurement condition Vcc=+5V, RL=10kΩ

According to which the following conditions are true the maximum continuous DC primary current plot shows the boundary of the area.

- ① $I_p < I_{PM}$
- ② Junction temperature $T_j < 125^\circ\text{C}$
- ③ Resistor power dissipation $< 0.5 \times$ rated power

Frequency derating

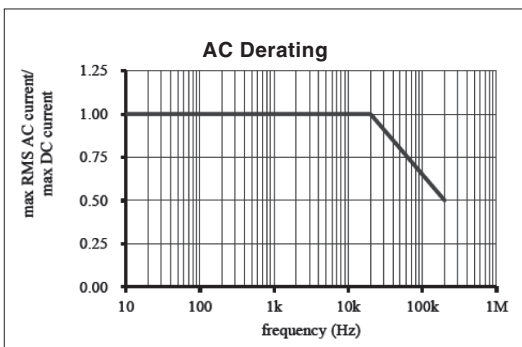

Figure 7 : Maximum RMS AC primary current/maximum DC primary current vs frequency

Reference voltage

The Ref pin has two modes Ref IN and Ref OUT. If you do not want to use the Ref pin, please unconnected.

< Ref OUT mode >

The 2.5V internal precision reference is used by the transducer as the reference point for bipolar measurements;

< Ref IN mode >

An external reference voltage is connected to the Ref pin; this voltage is specified in the range 0 to 4 V , its voltage is used as the reference voltage at the time of measurement.

- either to source a typical current of $(V_{ref} - 2.5) / 680$, the maximum value will be 2.2mA typ. when $V_{ref2} = 4V$.
- or to sink a typical current of $(2.5 - V_{ref2}) / 680$, the maximum value will be 3.68mA typ. when $V_{ref2} = 0V$.

The following graphs show how the measuring range of each transducer version depends on external reference voltage value V_{ref2} .

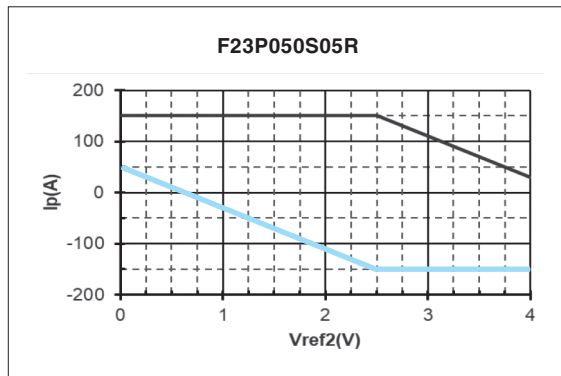

Upper limit : $I_p = 150$ (Vref2 = 0...2.5V)
 $I_p = -80 \times V_{ref2} + 350$ (Vref2 = 2.5...4V)
 Lower limit : $I_p = -80 \times V_{ref2} + 50$ (Vref2 = 0...2.5V)
 $I_p = -150$ (Vref2 = 2.5...4V)

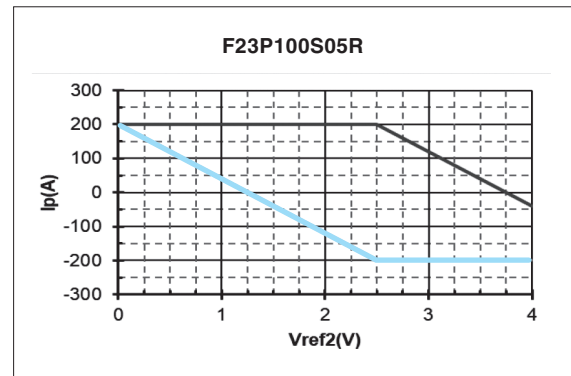

Upper limit : $I_p = 200$ (Vref2 = 0...2.5V)
 $I_p = -160 \times V_{ref2} + 600$ (Vref2 = 2.5...4V)
 Lower limit : $I_p = -160 \times V_{ref2} + 200$ (Vref2 = 0...2.5V)
 $I_p = -200$ (Vref2 = 2.5...4V)

CONNECTION

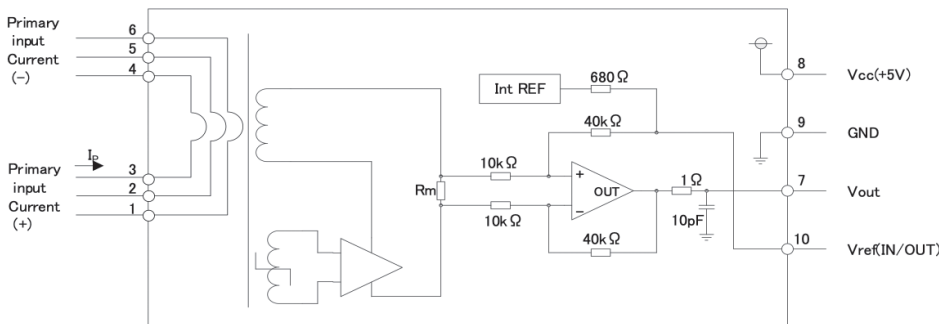

Primary winding Np	Primary current Ip [A]	wiring	Primary resistance Rp [mΩ]
3	Ip/3		1
2	Ip/2		0.45
1	Ip		0.1

DIMENSIONS (mm)

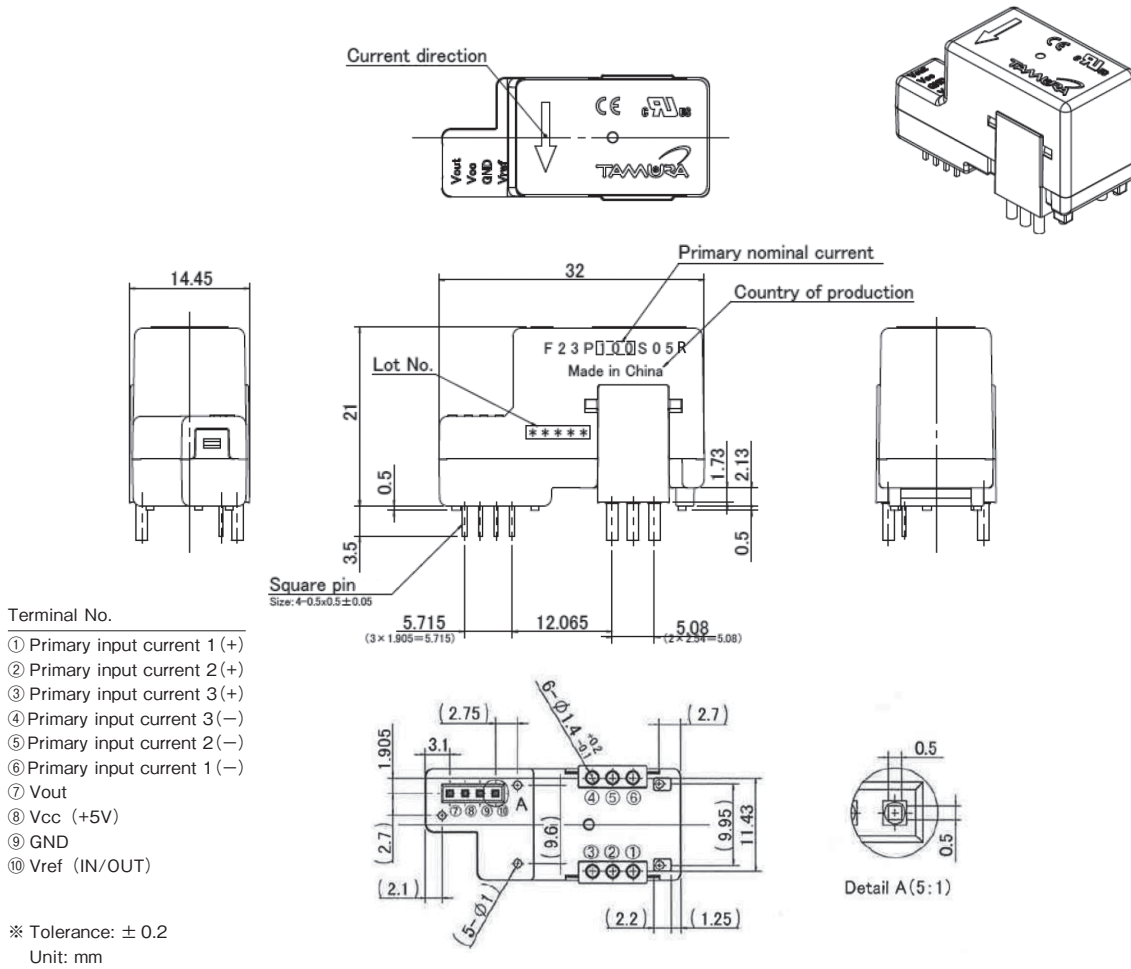

RECOMMENDED HOLE DIAMETER (mm)

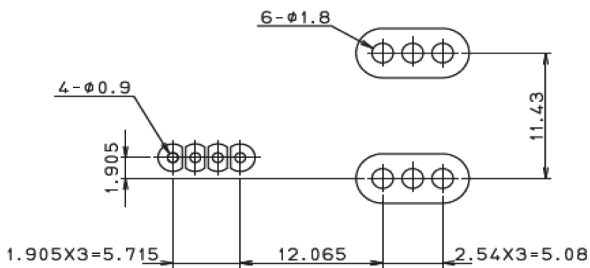

Fluxgate system / Voltage-output type, Through Type

F26PxxxS05 SERIES

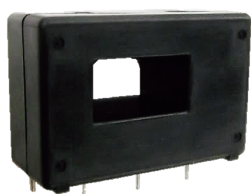

ABSOLUTE MAXIMUM RATINGS

Parameters	Symbol	Unit	Value	Comment
Supply voltage	Vcc	V	+7	
Primary conductor temperature	—	°C	105	
ESD (HBM: Human Body Model)	—	kV	4	C=150 pF, R=330 Ω

ISOLATION CHARACTERISTICS

Parameters	Symbol	Unit	Value	Comment
Insulation voltage	Vd	—	AC4300 V, for 1minute (Sensing current 0.5 mA)	Primary ⇔ Secondary
Impulse withstand voltage	Vw	kV	10	Primary ⇔ Secondary Input waveform : • Front time 1.2 μs • Time to half value 50 μs • single
Insulation Resistance	R _{IS}	—	≥ 500M Ω (at DC500V)	Primary ⇔ Secondary
Clearance distance	d _{Cl}	mm	12.7 (MIN)	Primary ⇔ Secondary
Creepage distance	d _{Cp}	mm	12.7 (MIN)	Primary ⇔ Secondary
Case material	—	—	UL94 V-0	
Comparative Tracking Index : (CTI)	CTI	V	600 (group I)	
Application example	—	—	600V, CAT III, PD2	Reinforced isolation, non uniform field according to EN62477-1:2012 and EN62477-1:2012/A11:2014.
	—	—	1000V, CAT III, PD2	Basic isolation, non uniform field according to EN62477-1:2012 and EN62477-1:2012/A11:2014.

ENVIRONMENTAL AND MECHANICAL CHARACTERISTICS

Parameters	Symbol	Unit	Value			Comment
			MIN	TYP	MAX	
Ambient operating temperature	T _A	°C	- 40		+ 85	
Ambient storage temperature	T _S	°C	- 40		+ 85	
Mass	m	g		33		

SPECIFICATIONS

Ta=+25°C, RL=10kΩ, Vcc=+5V

Parameters	Symbol	Unit	Value			Comment
			MIN	TYP	MAX	
Primary nominal current	F26P050S05	IPN	A		50	
	F26P100S05				100	
	F26P150S05				150	
Primary current, measuring range (at Vcc= + 5V, Ta= + 85°C)	F26P050S05	IPM	A	- 150		150
	F26P100S05			- 270		270
	F26P150S05			- 230		230
Number of secondary turns	F26P050S05	Ns	T		1258	
	F26P100S05				1258	
	F26P150S05				1588	
Supply Voltage	Vcc	V	4.75	5.00	5.25	
Consumption current (at IP=0 A)	Icc	mA		19		Icc=19+Ip/Ns+Vout/RL
Reference voltage (output) (at IP=0 A)	Vref1	V	2.495	2.500	2.505	Ref OUT mode
Reference voltage (input)	Vref2	V	0		4	Ref IN mode
Output voltage (at Ip=0A)	Vout	V		Vref1,Vref2		
Electrical offset voltage * 1	Voe	mV	- 1.0		+1.0	Voe=Vout (at Ip=0 A)-Vref
Electrical offset current referred to primary	F26P050S05	loe	mA	- 80		+80
	F26P100S05			- 160		+160
	F26P150S05			- 240		- 240
Temperature coefficient of Vref1	TCVref1	ppm/K			± 50	
Temperature coefficient of Output voltage (at Ip=0 A)	TCVo	ppm/K			± 10	ppm/K of 2.5 V (-40°C~+85°C)
Theoretical sensitivity	F26P050S05	Gth	mV/A		12.50	
	F26P100S05				6.25	
	F26P150S05				4.17	
Sensitivity error * 2	εG	%	- 0.7		+0.7	
Temperature coefficient of Sensitivity (at Ta= - 40°C~+ 85°C)	TCG	ppm/K			± 40	
Sensitivity linearity error (at IPN) * 2	εL	%	- 0.1		+0.1	
Peak to peak output ripple at oscillator frequency (f typ=450kHz)	—	mV		20		RL=1 kΩ , at Ip=0 A
Reaction time (at 10% of IPN) * 2	tra	μs		0.6		RL=1 kΩ , di/dt=100 A/μs
Response time (at 70% of IPN) * 2	tr	μs		0.6		RL=1 kΩ , di/dt=100 A/μs
Frequency bandwidth (± 3 dB) * 2 * 3	BW	kHz		100		RL=1 kΩ
Overall accuracy * 2	XG	%	- 0.96		+0.96	XG=(100 × Voe/625)+ εG+ εL

*1 Offset voltage value is after removal of core hysteresis.

*2 Measurement condition : Primary conductor (bus bar) cross sectional area is as same as through hole, and penetration with 1 turn in through hole. Differences occur depending on the conditions of the primary conductor (busbar).

*3 High fundamental frequency primary current and/or harmonic current may result in excessive heating in magnetic core.

*4 The measurement range is less than F26P100S05.

STANDARDS

EN62477-1:2012 and EN62477-1:2012/A11:2014 , UL508 (File No.E243511)

※ Please refer to the another sheet about conditions of UL Recognition.

CHARACTERISTIC CURVE (TYP)

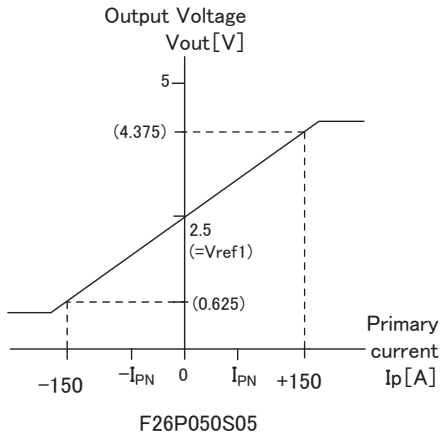

Figure 1 : Linearity curve (Internal reference voltage)

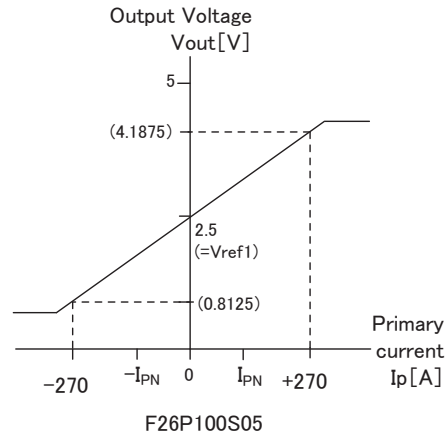

Figure 2 : Linearity curve (Internal reference voltage)

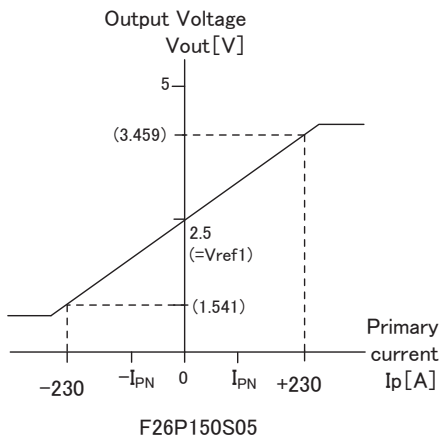

Figure 3 : Linearity curve (Internal reference voltage)

SUPPORT DOCUMENTATION

Maximum repetitive primary current

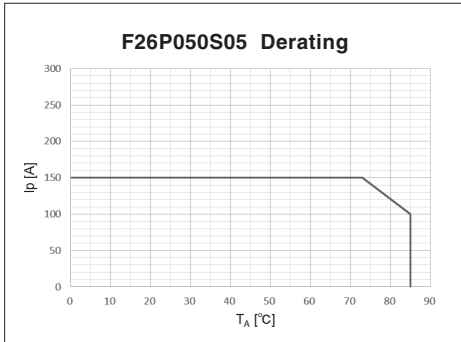

Figure 4 : Ip vs TA for F26P050S05

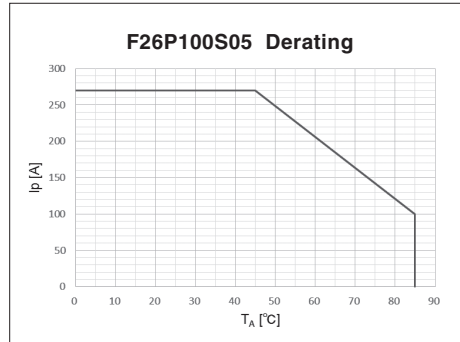

Figure 5 : Ip vs TA for F26P100S05

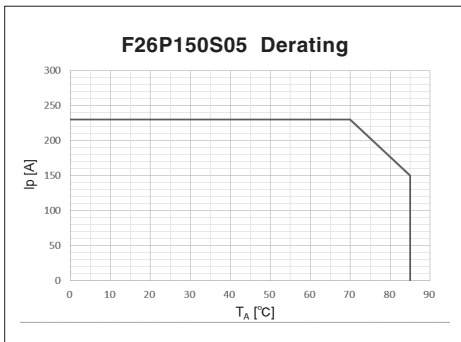

Figure 6 : Ip vs TA for F26P150S05

According to which the following conditions are true the maximum repetitive primary current plot shows the boundary of the area.

- ① $I_p < I_{pm}$
- ② Junction temperature $T_j < 125^\circ\text{C}$
- ③ Resistor power dissipation $< 0.5 \times \text{rated power}$

SUPPORT DOCUMENTATION

Reference voltage

The Ref pin has two modes Ref IN and Ref OUT.

< Ref OUT mode >

The 2.5 V internal precision reference is used by the transducer as the reference point for bipolar measurements.

< Ref IN mode >

An external reference voltage is connected to the Ref pin. this voltage is specified in the range 0 to 4 V. its voltage is used as the reference voltage at the time of measurement.

- either to source a typical current of $(V_{ref2}-2.5)/680$, the maximum value will be 2.2 mA typ. when $V_{ref2} = 4$ V.
- or to sink a typical current of $(2.5-V_{ref2})/680$, the maximum value will be 3.68 mA typ. when $V_{ref2} = 0$ V.

The following graphs show how the measuring range of each transducer version depends on external reference voltage value V_{ref2} .

$R_L = 1 \text{ k}\Omega$, $V_{CC} = +5 \text{ V}$, $T_A = -40 \sim +85 \text{ }^\circ\text{C}$

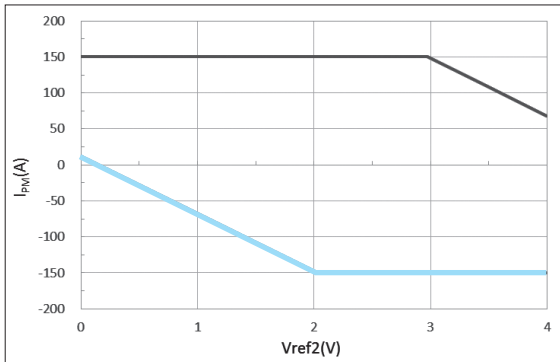

Figure 7 : I_{PM} vs V_{ref2} for F26P050S05

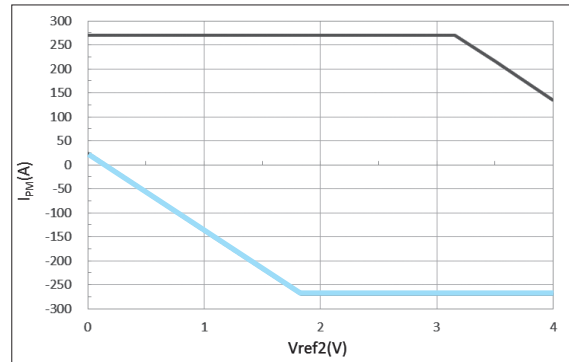

Figure 8 : I_{PM} vs V_{ref2} for F26P100S05

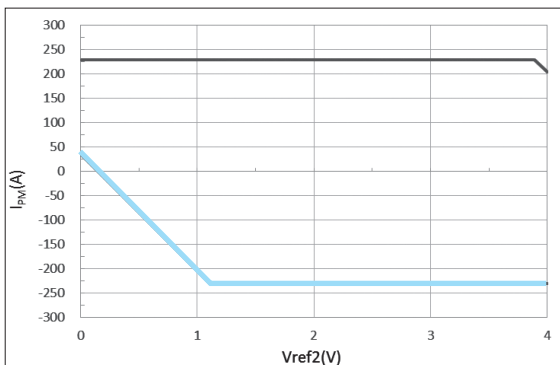

Figure 9 : I_{PM} vs V_{ref2} for F26P150S05

e. g. ; In case of F26P100S05

- Upper limit : $I_p = +270 \text{ A}$ ($V_{ref2} = 0 \text{ V} \sim 3.16 \text{ V}$)
- $I_p = +270 - (V_{ref2} - 3.16 \text{ V}) / 0.00625$ ($V_{ref2} = 3.16 \text{ V} \sim 4 \text{ V}$)
- Lower limit : $I_p = -270 \text{ A}$ ($V_{ref2} = 1.84 \text{ V} \sim 4 \text{ V}$)
- $I_p = -270 - (V_{ref2} - 1.84 \text{ V}) / 0.00625$ ($V_{ref2} = 0 \text{ V} \sim 1.84 \text{ V}$)

If you do not want to use the Ref pin, please unconnected.

CONNECTION

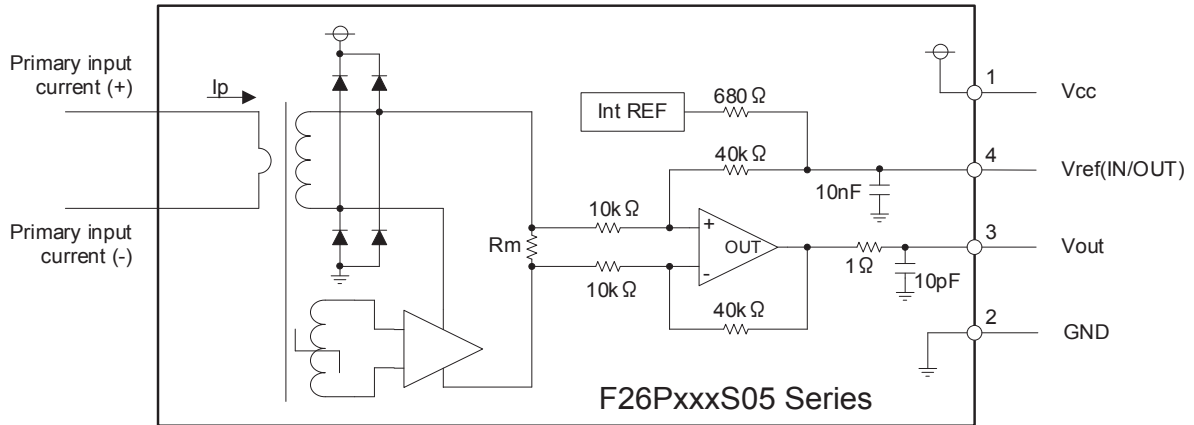

DIMENSIONS (mm)

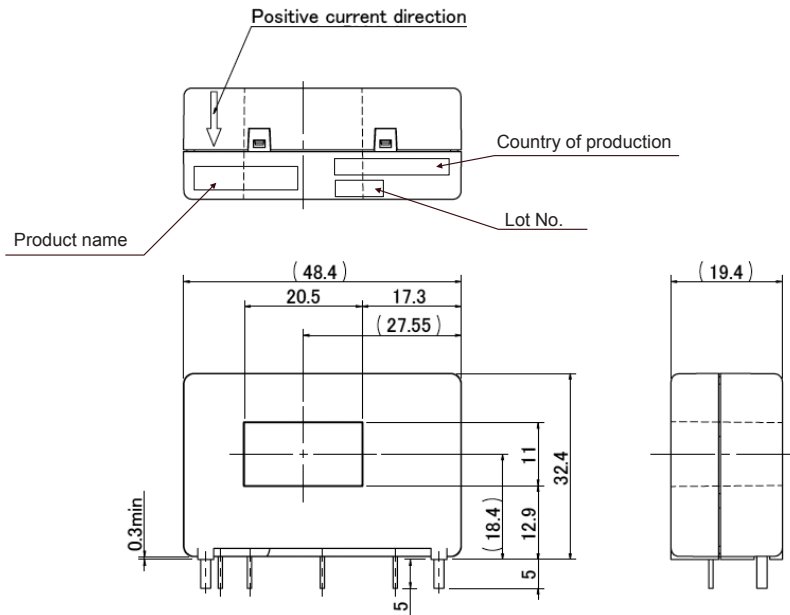

- Terminal No.
- ① Vcc (+5V)
 - ② GND
 - ③ Vout
 - ④ Vref (IN/OUT)

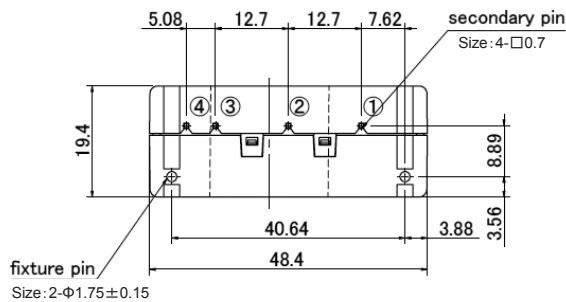

※ Tolerance: ± 0.5
Unit: mm

RECOMMENDED HOLE DIAMETER (mm)

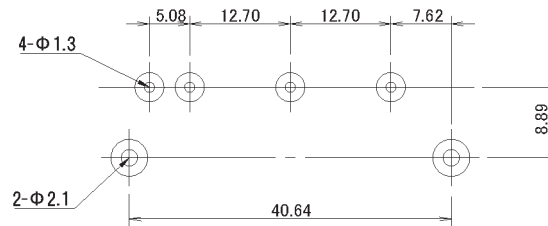

TYPE DESIGNATION

F26 P xxx S 05
 ① ② ③ ④ ⑤ ⑥

- ① Model (3 figures)
F26 : Series
- ② Mounting configuration (1 figure)
P : PCB Mounting type
- ③ Measurement current range (3 figures)
050 : 50A
100 : 100A
150 : 150A
- ④ Control power supply type (1 figure)
S : Single supply
- ⑤ Power supply voltage (2 digits)
05 : 5V
- ⑥ Special specification
(none) : Standard type.
A : Output voltage waveform distortion improvement type.

Fluxgate system / Voltage-output type, Through Type

F26PxxxS05A SERIES

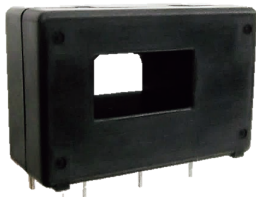

F26PxxxS05A series is a model that output voltage waveform distortion improvement of the F26PxxxS05 series. For details, please refer to supplementary material(P6).

ABSOLUTE MAXIMUM RATINGS

Parameters	Symbol	Unit	Value	Comment
Supply voltage	V _{CC}	V	+7	
Primary conductor temperature	—	°C	105	
ESD (HBM: Human Body Model)	—	kV	4	C=150 pF, R=330 Ω

ISOLATION CHARACTERISTICS

Parameters	Symbol	Unit	Value	Comment
Insulation voltage	V _d	—	AC4300 V, for 1minute (Sensing current 0.5 mA)	Primary ⇔ Secondary
Impulse withstand voltage	V _w	kV	10	Primary ⇔ Secondary Input waveform : • Front time 1.2 μs • Time to half value 50 μs • single
Insulation Resistance	R _{IS}	—	≧ 500M Ω (at DC500V)	Primary ⇔ Secondary
Clearance distance	d _{cl}	mm	12.7 (MIN)	Primary ⇔ Secondary
Creepage distance	d _{cp}	mm	12.7 (MIN)	Primary ⇔ Secondary
Case material	—	—	UL94 V-0	
Comparative Tracking Index : (CTI)	CTI	V	600 (group I)	
Application example	—	—	600V, CAT III, PD2	Reinforced isolation, non uniform field according to EN62477-1:2012 and EN62477-1:2012/A11:2014.
	—	—	1000V, CAT III, PD2	Basic isolation, non uniform field according to EN62477-1:2012 and EN62477-1:2012/A11:2014.

ENVIRONMENTAL AND MECHANICAL CHARACTERISTICS

Parameters	Symbol	Unit	Value			Comment
			MIN	TYP	MAX	
Ambient operating temperature	T _A	°C	- 40		+ 85	
Ambient storage temperature	T _S	°C	- 40		+ 85	
Mass	m	g		33		

SPECIFICATIONS

Ta=+25°C, RL=10kΩ, Vcc=+5V

Parameters	Symbol	Unit	Value			Comment
			MIN	TYP	MAX	
Primary nominal current	F26P050S05A	IPN	A		50	
	F26P100S05A				100	
	F26P150S05A				150	
Primary current, measuring range (at Vcc= + 5V, Ta= + 85°C)	F26P050S05A	IPM	A	- 150		150
	F26P100S05A			- 270		270
	F26P150S05A			- 230		230
Number of secondary turns	F26P050S05A	Ns	T		1258	
	F26P100S05A				1258	
	F26P150S05A				1588	
Supply Voltage	Vcc	V	4.75	5.00	5.25	
Consumption current (at IP=0 A)	Icc	mA		20		Icc=20+Ip/Ns+Vout/RL
Reference voltage (output) (at IP=0 A)	Vref1	V	2.495	2.500	2.505	Ref OUT mode
Reference voltage (input)	Vref2	V	0		4	Ref IN mode
Output voltage (at Ip=0A)	Vout	V		Vref1,Vref2		
Electrical offset voltage * 1	Voe	mV	- 1.0		+1.0	Voe=Vout (at Ip=0 A)-Vref
Electrical offset current referred to primary	F26P050S05A	Ioe	mA	- 80		+80
	F26P100S05A			- 160		+160
	F26P150S05A			- 240		- 240
Temperature coefficient of Vref1	TCVref1	ppm/K			± 50	
Temperature coefficient of Output voltage (at Ip=0 A)	TCVo	ppm/K			± 10	ppm/K of 2.5 V (-40°C~+85°C)
Theoretical sensitivity	F26P050S05A	Gth	mV/A		12.50	
	F26P100S05A				6.25	
	F26P150S05A				4.17	
Sensitivity error * 2	εG	%	- 0.7		+0.7	
Temperature coefficient of Sensitivity (at Ta= - 40°C~+ 85°C)	TCG	ppm/K			± 40	
Sensitivity linearity error (at IPN) * 2	εL	%	- 0.1		+0.1	
Peak to peak output ripple at oscillator frequency (f typ=450kHz)	—	mV		16		RL=1 kΩ , at Ip=0 A
Reaction time (at 10% of IPN) * 2	tra	μs		1		RL=1 kΩ , di/dt=100 A/μs
Response time (at 70% of IPN) * 2	tr	μs		1		RL=1 kΩ , di/dt=100 A/μs
Frequency bandwidth (± 3 dB) * 2 * 3	BW	kHz		100		RL=1 kΩ
Overall accuracy * 2	XG	%	- 0.96		+0.96	XG=(100 × Voe/625)+ εG+ εL

*1 Offset voltage value is after removal of core hysteresis.

*2 Measurement condition : Primary conductor (bus bar) cross sectional area is as same as through hole, and penetration with 1 turn in through hole. Differences occur depending on the conditions of the primary conductor (busbar).

*3 High fundamental frequency primary current and/or harmonic current may result in excessive heating in magnetic core.

*4 The measurement range is less than F26P100S05.

STANDARDS

EN62477-1:2012 and EN62477-1:2012/A11:2014 , UL508 (File No.E243511)

※ Please refer to the another sheet about conditions of UL Recognition.

CHARACTERISTIC CURVE (TYP)

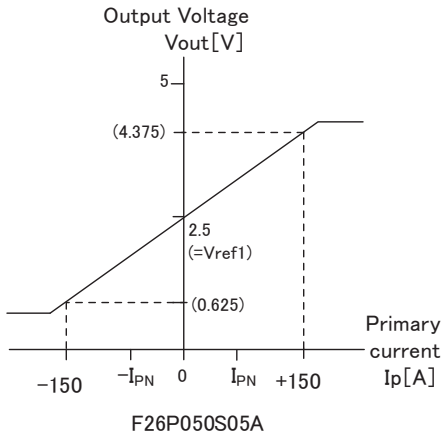

Figure 1 : Linearity curve (Internal reference voltage)

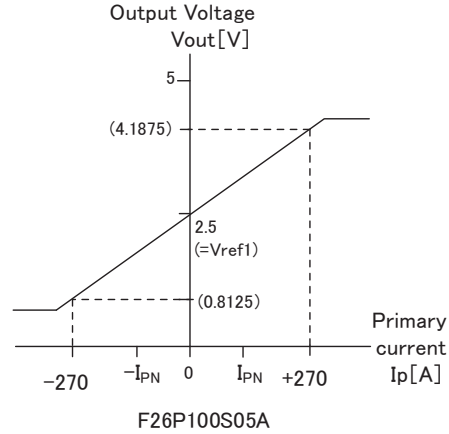

Figure 2 : Linearity curve (Internal reference voltage)

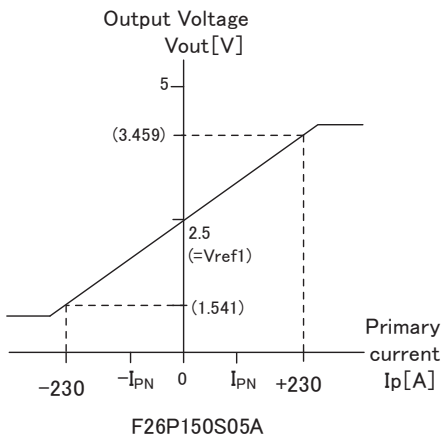

Figure 3 : Linearity curve (Internal reference voltage)

SUPPORT DOCUMENTATION

Maximum repetitive primary current

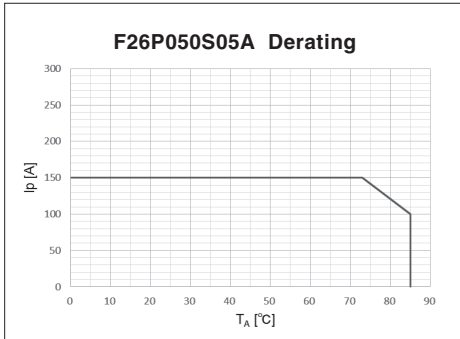

Figure 4 : Ip vs TA for F26P050S05A

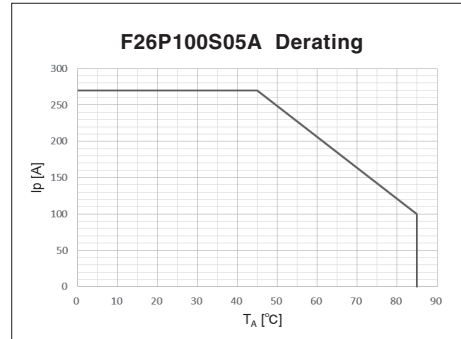

Figure 5 : Ip vs TA for F26P100S05A

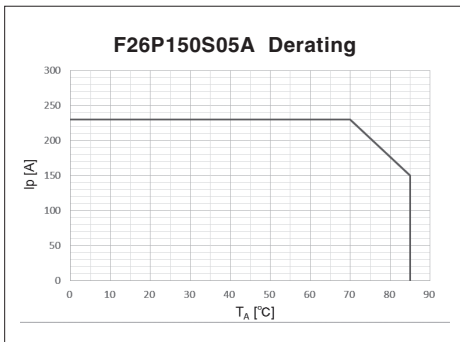

Figure 6 : Ip vs TA for F26P150S05A

According to which the following conditions are true the maximum repetitive primary current plot shows the boundary of the area.

- ① $I_p < I_{pm}$
- ② Junction temperature $T_j < 125^\circ\text{C}$
- ③ Resistor power dissipation $< 0.5 \times \text{rated power}$

SUPPORT DOCUMENTATION

Reference voltage

The Ref pin has two modes Ref IN and Ref OUT.

< Ref OUT mode >

The 2.5 V internal precision reference is used by the transducer as the reference point for bipolar measurements.

< Ref IN mode >

An external reference voltage is connected to the Ref pin. this voltage is specified in the range 0 to 4 V. its voltage is used as the reference voltage at the time of measurement.

- either to source a typical current of $(V_{ref2}-2.5)/680$, the maximum value will be 2.2 mA typ. when $V_{ref2} = 4$ V.
- or to sink a typical current of $(2.5-V_{ref2})/680$, the maximum value will be 3.68 mA typ. when $V_{ref2} = 0$ V.

The following graphs show how the measuring range of each transducer version depends on external reference voltage value V_{ref2} .

$R_L = 1 \text{ k}\Omega$, $V_{CC} = +5 \text{ V}$, $T_A = -40 \sim +85 \text{ }^\circ\text{C}$

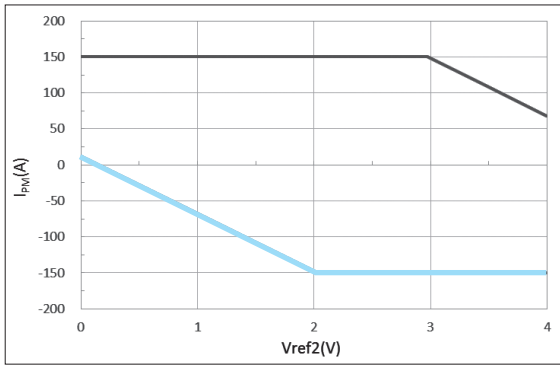

Figure 7 : I_{PM} vs V_{ref2} for F26P050S05A

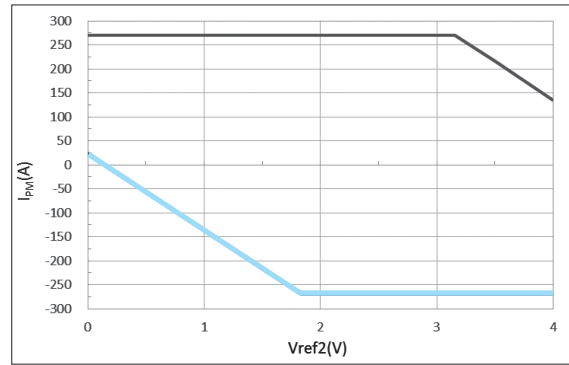

Figure 8 : I_{PM} vs V_{ref2} for F26P100S05A

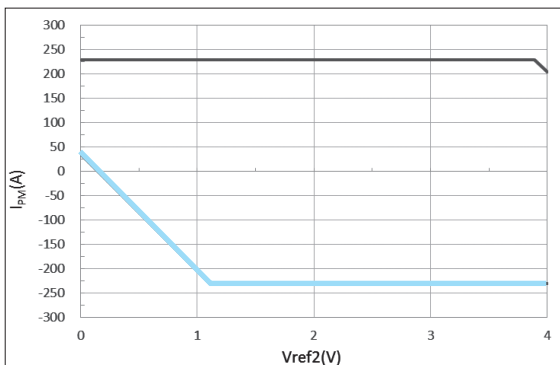

Figure 9 : I_{PM} vs V_{ref2} for F26P150S05A

e. g. ; In case of F26P100S05A

- Upper limit : $I_p = +270 \text{ A}$ ($V_{ref2} = 0 \text{ V} \sim 3.16 \text{ V}$)
- $I_p = +270 - (V_{ref2} - 3.16 \text{ V}) / 0.00625$ ($V_{ref2} = 3.16 \text{ V} \sim 4 \text{ V}$)
- Lower limit : $I_p = -270 \text{ A}$ ($V_{ref2} = 1.84 \text{ V} \sim 4 \text{ V}$)
- $I_p = -270 - (V_{ref2} - 1.84 \text{ V}) / 0.00625$ ($V_{ref2} = 0 \text{ V} \sim 1.84 \text{ V}$)

If you do not want to use the Ref pin, please unconnected.

SUPPORT DOCUMENTATION

Information on F26PxxxS05A series.

F26PxxxS05A series is a model that output voltage waveform distortion improvement of the F26PxxxS05 series.
Please select according to the application.

e. g. F26P100S05A

Measurement condition $T_A=25\text{ }^\circ\text{C}$ $R_L=1\text{ k}\Omega$ $I_p=20\text{ A}$ $V_{cc}=+5\text{ V}$

Primary conductor (bus bar) cross sectional area is as same as through hole, and penetration with 1 turn in through hole.

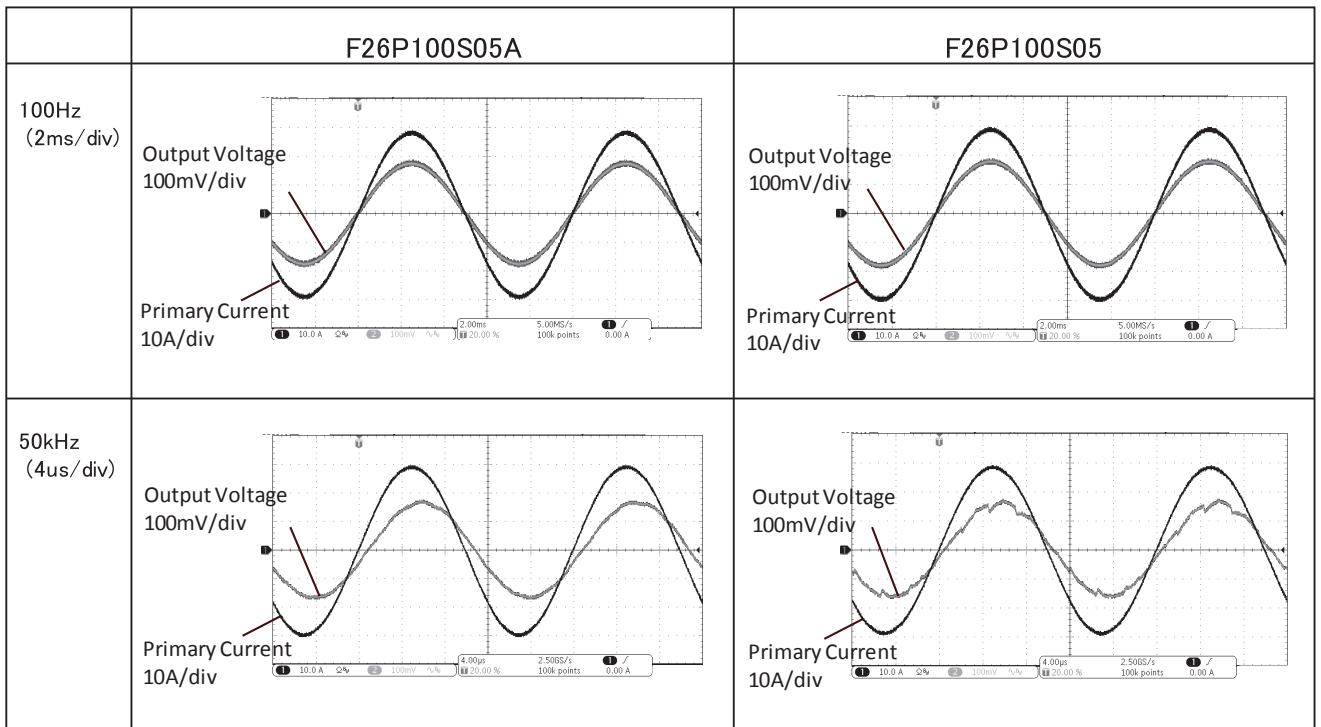

Differences occur depending on the conditions of the primary conductor (busbar).
Please use it after actual machine verification.

CONNECTION

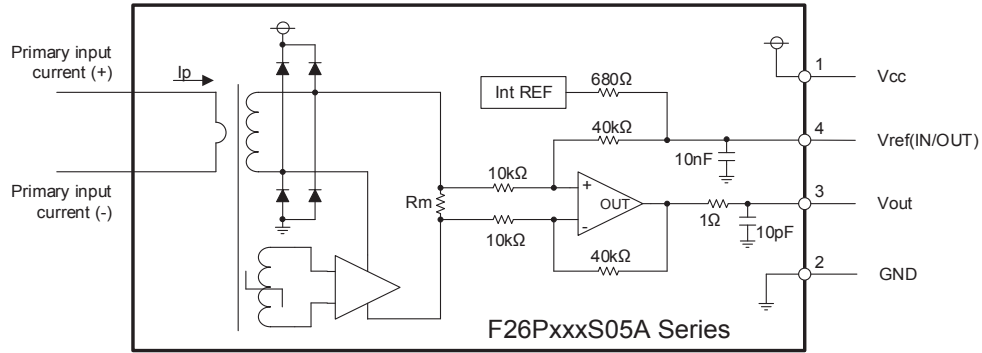

DIMENSIONS (mm)

※ Tolerance: ±0.5
Unit: mm

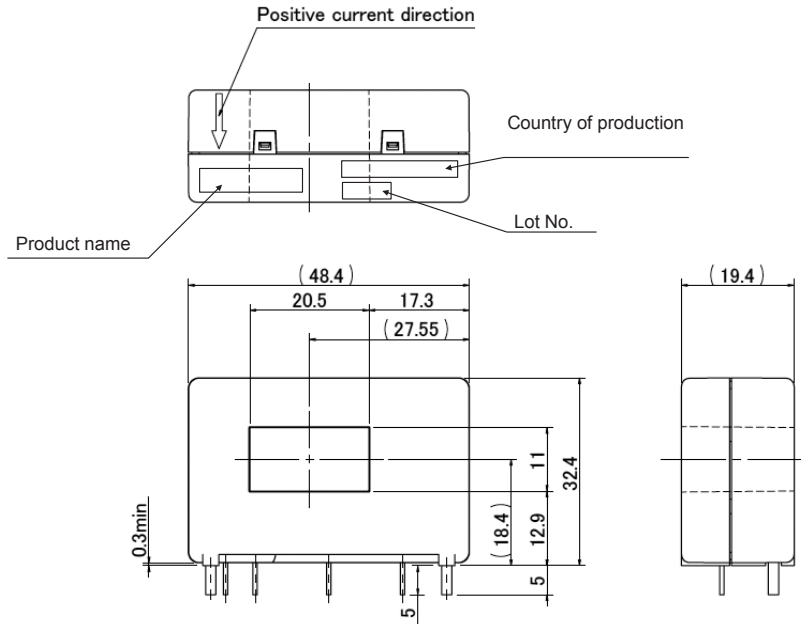

- Terminal No.
- ① Vcc (+5V)
 - ② GND
 - ③ Vout
 - ④ Vref (IN/OUT)

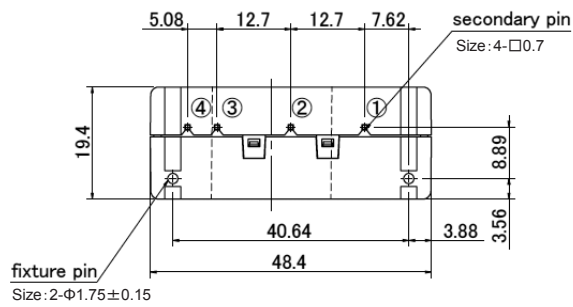

RECOMMENDED HOLE DIAMETER (mm)

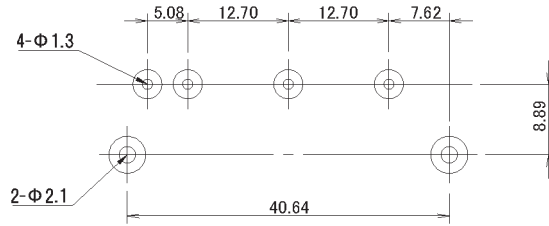

TYPE DESIGNATION

F26 P xxx S 05 A
 ① ② ③ ④ ⑤ ⑥

- ① Model (3 figures)
F26 : Series
- ② Mounting configuration (1 figure)
P : PCB Mounting type
- ③ Measurement current range (3 figures)
050 : 50A
100 : 100A
150 : 150A
- ④ Control power supply type (1 figure)
S : Single supply
- ⑤ Power supply voltage (2 digits)
05 : 15V
- ⑥ Special specification
(none) : Standard type.
A : Output voltage waveform distortion improvement type.

Fluxgate system / Voltage-output type, Through Type

F26P150S12



[STANDARDS]
·EN 62477-1

RoHS

ABSOLUTE MAXIMUM RATINGS

Parameters	Symbol	Unit	Value	Comment
Supply voltage	Vcc	V	+14.5	
Primary conductor temperature	—	°C	100	
External voltage applied to Vref (out) terminal	—	V	5	Vref (out) terminal has only output function. There is no input function.

ISOLATION CHARACTERISTICS

Parameters	Symbol	Unit	Value	Comment
Insulation voltage	Vd	—	AC4300 V, for 1minute (Sensing current 0.5 mA)	Primary ⇔ Secondary
Impulse withstand voltage	Vw	kV	10	Primary ⇔ Secondary Input waveform : · Front time 1.2 μs · Time to half value 50 μs · single
Insulation resistance	R _{IS}	—	≥ 500M Ω (at DC500V)	Primary ⇔ Secondary
Clearance distance	d _{Cl}	mm	12.7 (MIN)	Primary ⇔ Secondary
Creepage distance	d _{cp}	mm	12.7 (MIN)	Primary ⇔ Secondary
Case material	—	—	UL94 V-0	
Comparative Tracking Index ; (CTI)	CTI	V	600 (group I)	

ENVIRONMENTAL AND MECHANICAL CHARACTERISTICS

Parameters	Symbol	Unit	Value			Comment
			MIN	TYP	MAX	
Ambient operating temperature	T _A	°C	- 40		+ 85	
Ambient storage temperature	T _S	°C	- 40		+ 85	
Mass	m	g		38.5		

SPECIFICATIONS

T_A=+25°C, R_L=OPEN, V_{CC}=+12V

Parameters	Symbol	Unit	Value			Comment
			MIN	TYP	MAX	
Primary nominal current	I _{PN}	A		150		
Primary current, measuring range (at V _{CC} = +12V, T _A = +85°C)	I _{PM}	A	- 450		450	
Number of secondary turns	N _s	T		2150		
Supply Voltage	V _{CC}	V	11.4	12	12.6	
Consumption current (at I _P =0 A)	I _{CC}	mA		36.5		I _{CC} =36.5+I _P /N _s +V _{out} /R _L
Reference voltage (output) (at I _P =0 A) * 1	V _{ref(out)}	V	2.495	2.500	2.505	No Load
Output voltage (at I _P =0A)	V _{out}	V		V _{ref(out)}		
Electrical offset voltage * 2	V _{oe}	mV	- 1.0		+1.0	V _{oe} =V _{out} (at I _P =0 A)-V _{ref(out)}
Electrical offset current referred to primary	I _{oe}	mA	- 240		+240	
Temperature coefficient of V _{ref} (out)	TCV _{ref}	ppm/K			±50	
Temperature coefficient of Output voltage (at I _P =0 A)	TCV _o	ppm/K			±10	ppm/K of 2.5 V (-40°C~+85°C)
Theoretical sensitivity	G _{th}	mV/A		4.167		625 mV(at I _{PN}), G _{th} = V _{out} -V _{ref(out)} /I _{PN}
Sensitivity error * 3	ε _G	%	- 0.7		+0.7	
Temperature coefficient of Sensitivity (at T _A = -40°C~ +85°C)	TCG	ppm/K			±40	
Linearity error (at I _{PN}) * 3	ε _L	%	- 0.1		+0.1	
Peak to peak output ripple at oscillator frequency (f typ=600kHz)	—	mV		16		R _L =1 k Ω , at I _P =0 A
Reaction time (at 10% of I _{PN}) * 3	t _{ra}	μs		1		R _L =1 k Ω , di/dt=100 A/μs
Response time (at 70% of I _{PN}) * 3	t _r	μs		1		R _L =1 k Ω , di/dt=100 A/μs
Frequency bandwidth (± 3 dB) * 3 * 4	BW	kHz		100		R _L =1 k Ω
Overall accuracy * 3	X _G	%	- 0.96		+0.96	X _G =(100 × V _{oe} /625)+ ε _G + ε _L

- *1 If the output impedance of the V_{ref} (out) pin is small, the accuracy of the reference voltage will decrease.
- *2 Offset voltage value is after removal of core hysteresis.
- *3 Measurement condition : Primary conductor (bus bar) cross sectional area is as same as through hole, and penetration with 1 turn in through hole. Differences occur depending on the conditions of the primary conductor (bus bar).
- *4 High fundamental frequency primary current and/or harmonic current may result in excessive heating in magnetic core.

STANDARDS



EN62477-1:2012, EN62477-1:2012/A1:2017 and EN62477-1:2012/A11:2014
 Rated voltage 600V, CAT III, PD2, Reinforced isolation, non uniform field

CHARACTERISTIC CURVE (TYP)

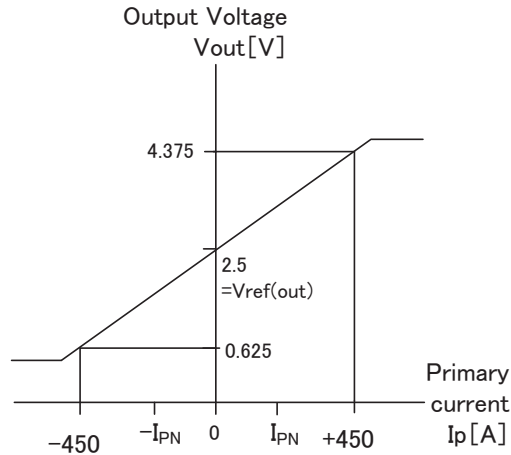

F26P150S12

Figure 1 : Linearity curve

SUPPORT DOCUMENTATION

Maximum repetitive primary current

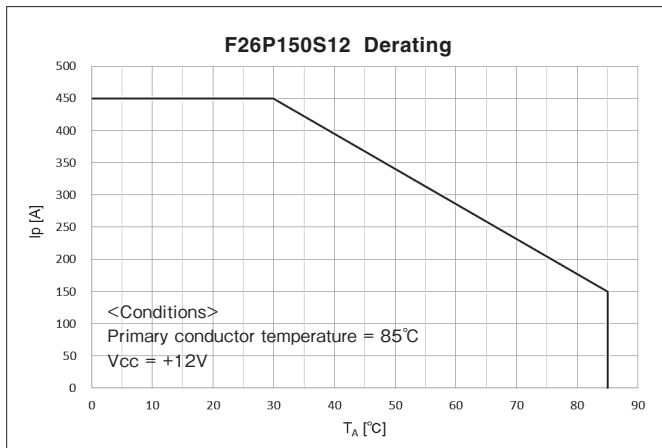

Figure 2 : Ip vs TA for F26P150S12

According to which the following conditions are true the maximum repetitive primary current plot shows the boundary of the area.

- ① $I_p < I_{pm}$
- ② Junction temperature $T_j <$ Absolute maximum rating of internal components.
- ③ Resistor power dissipation $< 0.5 \times$ rated power

Reference voltage

The Vref(out) pin is used for output only. A precision internal reference voltage of 2.5V can be used as a reference point for bipolar measurements. An external reference voltage cannot be input for use.

If you do not want to use the Vref(out) pin, please unconnected.

CONNECTION

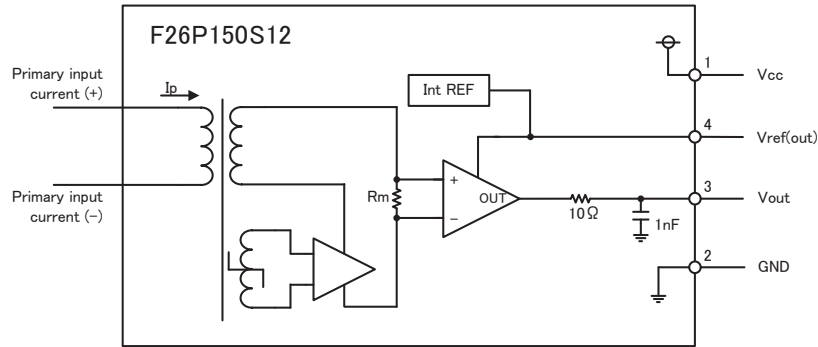

DIMENSIONS (mm)

※ Tolerance: ± 0.5
Unit: mm

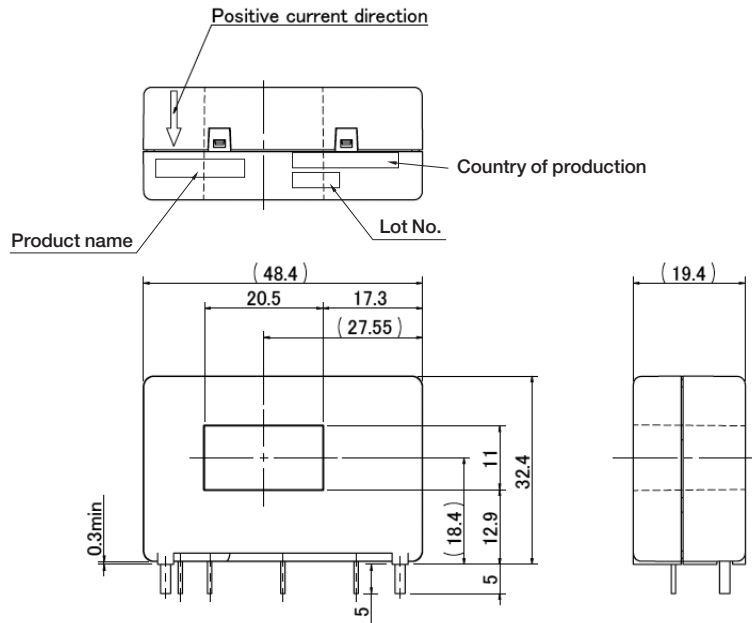

Terminal No.

- ① Vcc (+12V)
- ② GND
- ③ Vout
- ④ Vref (OUT)

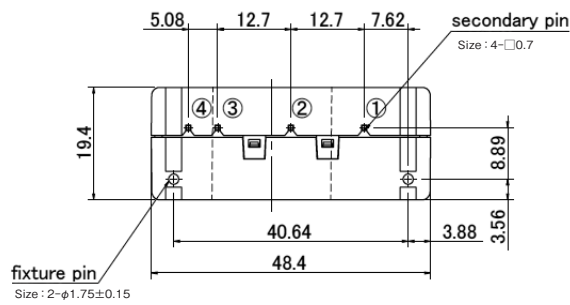

RECOMMENDED HOLE DIAMETER (mm)

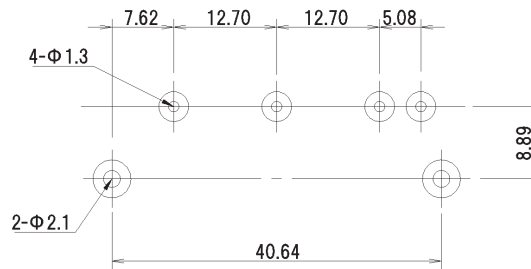

TYPE DESIGNATION

F26 P 150 S 12
 ① ② ③ ④ ⑤

- ① Model (3 figures)
F26 : Series
- ② Mounting configuration (1 figure)
P : PCB Mounting type
- ③ Primary nominal current (3 figures)
150 : 150A
- ④ Control power supply type (1 figure)
S : Single supply
- ⑤ Power supply voltage (2 digits)
12 : +12V

Magnetic Proportion System

L18PxxxD15AHV SERIES

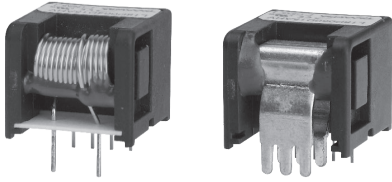

ABSOLUTE MAXIMUM RATINGS

Parameters	Symbol	Unit	Value	Comment
Supply voltage	Vcc	V	± 18V	

ISOLATION CHARACTERISTICS

Parameters	Symbol	Unit	Value	Comment
Insulation voltage	Vd	—	AC3000V, for 1minute (Sensing current 0.5mA)	Primary ⇔ Secondary
Impulse withstand voltage	Vw	kV	6.0	Primary ⇔ Secondary Input waveform : • Front time 1.2μs • Time to half value 50μs • single
Insulation resistance	R _{is}	—	≧ 500M Ω (at DC500V)	Primary ⇔ Secondary
Clearance distance	d _{ci}	—	9.2mm (MIN)	Primary ⇔ Secondary
			L18PxxxD15AHV xxx=003 ~ 030	
Creepage distance	d _{cp}	—	9.2mm (MIN)	Primary ⇔ Secondary
			L18PxxxD15AHV xxx=040 ~ 060	
Case material	—	—	UL94 V-0	
Comparative Tracking Index ; (CTI)	CTI	V	175 (group III a)	

ENVIRONMENTAL AND MECHANICAL CHARACTERISTICS

Parameters	Symbol	Unit	Value			Comment
			MIN	TYP	MAX	
Ambient operating	T _A	°C	- 30		+ 80	
Ambient storage temperature	T _S	°C	- 40		+ 85	
Mass	m	g		7		

SPECIFICATIONS

T_A=+25°C, R_L=10kΩ, V_{CC}=±15V

Parameters	Symbol	Unit	Value			Comment	
			MIN	TYP	MAX		
Primary nominal current	L18P003D15AHV	I _{PN}	A		3		
	L18P005D15AHV				5		
	L18P010D15AHV				10		
	L18P015D15AHV				15		
	L18P020D15AHV				20		
	L18P025D15AHV				25		
	L18P030D15AHV				30		
	L18P040D15AHV				40		
	L18P050D15AHV				50		
	L18P060D15AHV				60		
Primary current, measuring range * 1,2	L18P003D15AHV	I _{PM}	A	9			
	L18P005D15AHV			15			
	L18P010D15AHV			30			
	L18P015D15AHV			45			
	L18P020D15AHV			60			
	L18P025D15AHV			75			
	L18P030D15AHV			90			
	L18P040D15AHV			120			
	L18P050D15AHV			150			
	L18P060D15AHV			180			
Supply Voltage	V _{CC}	V		± 12 (± 5%)	± 15 (± 5%)		
Consumption current	I _{CC}	mA		14	18		
Rated output voltage	L18PxxxD15AHV xxx=003~030	V _O	V	3.960	4.000	4.040	at I _{PN}
	L18PxxxD15AHV xxx=040~060			3.950	4.000	4.050	
Offset voltage * 3	L18PxxxD15AHV xxx=003~030	V _{OF}	V	- 0.040	0.000	0.040	at I _P = 0A
	L18PxxxD15AHV xxx=040~060			- 0.050	0.000	0.050	
Hysteresis error	L18PxxxD15AHV xxx=003~030	V _{OH}	mV	- 25		25	at 0A → I _{PN} → 0A
	L18PxxxD15AHV xxx=040~060			- 40		40	
Temperature coefficient of V _O	T _C V _O	%/°C		- 0.1		+0.1	Without T _C V _{OF}
Temperature coefficient of	T _C V _{OF}	mV/°C		- 1.5		+1.5	at I _P = 0A
Linearity error (0A ~ I _{PN})	ε _L	%		- 1.0		+1.0	
Response time * 4	t _r	μs				5	di/dt=I _{PN} / μs

Anti-Sulfurated PCB coating : HumiSeal®, Resistors : Thick film (General purpose)
dv/dt improvement type

- *1 Also operate at V_{CC} = ± 12V power supplies , measuring range reduced to 2.5 x I_{PM}.
- *2 The value of measured current which indicates an output with a greater than ± 10% deviation from the theoretical output value.
- *3 Offset voltage value is after removal of core hysteresis.
- *4 The response time is the time difference from 10% of the applied input step current to 90% of the sensor output signal.

STANDARDS

UL508, CSA22.2 No.14 (UL File No.E243511)

EN 62477-1, IEC/EN61800-5-1

※ Please refer to the another sheet about conditions of UL Recognition.

CONNECTION

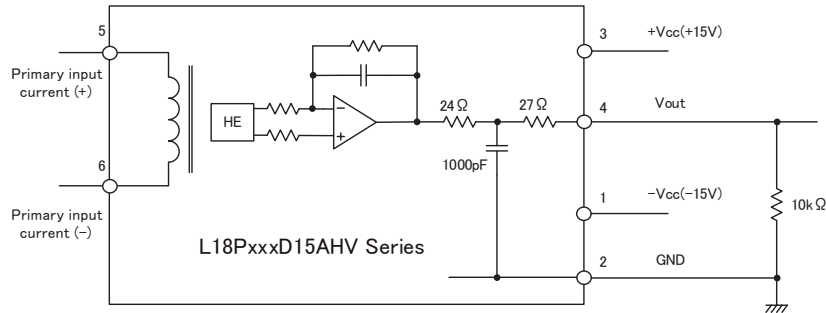

DIMENSIONS (mm)

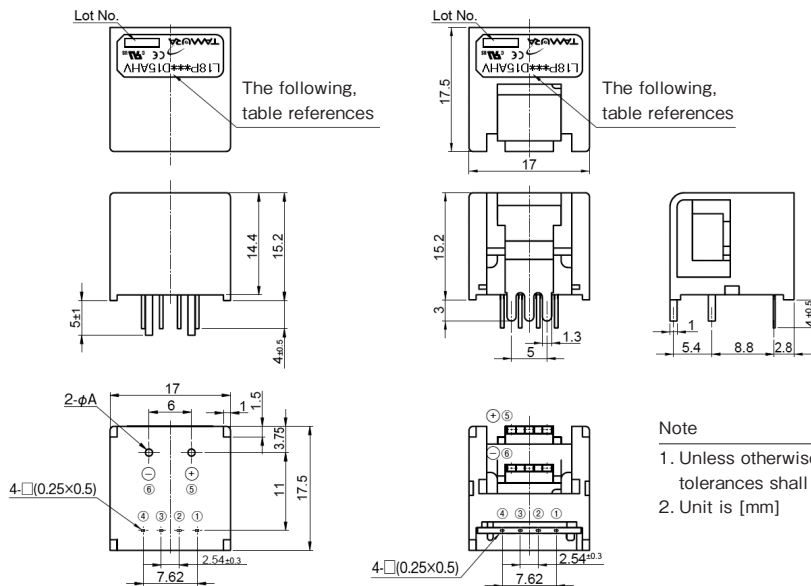

Terminal number

- ① -Vcc (-15V)
- ② GND
- ③ +Vcc (+15V)
- ④ Vout
- ⑤ Primary input current (+)
- ⑥ Primary input current (-)

Current	***	φA
3A	003	φ0.6
5A	005	φ0.8
10A	010	φ1.1
15A	015	φ1.4
20A	020	φ1.6
25A	025	φ1.6
30A	030	φ1.6
40A	040	Busbar
50A	050	Busbar
60A	060	Busbar

Note

- 1. Unless otherwise specified, tolerances shall be ± 0.5mm
- 2. Unit is [mm]

TYPE DESIGNATION

L18 P * D 15 AHV**
 ① ② ③ ④ ⑤ ⑥

- ① Model (4 figures)
L18 : Series
- ② Mounting configuration (1 figure)
P : PCB Mounting type
- ③ Measurement current range (3 figures)
Ex) 050 : 50A
- ④ Control power supply type (1 figure)
D : Dual supply
- ⑤ Power supply voltage (2 digits)
15 : 15V
- ⑥ Special specification
Dust-proof PCB coating : HumiSeal®
dv/dt improvement type

Magnetic Proportion System

L18P D15-OP SERIES

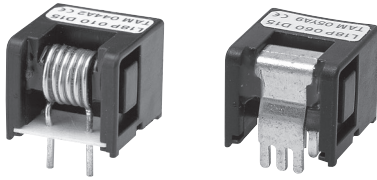

SPECIFICATIONS

Ta=25°C, RL=10kΩ, Vcc= ±15V

Spec	Types	L18P***D15-OP ***: Primary current code										
		*** :	003	005	010	015	020	025	030	040	050	060
Primary nominal current	If	3A	5A	10A	15A	20A	25A	30A	40A	50A	60A	
Primary wire	φ	0.6mm	0.8mm	1.1mm	1.4mm	1.6mm			bus-bar 1.0 × 6.3			
Saturation current	If max	If × 3*1										
Rated output voltage	Vo	4V ± 0.040V (at If)							4V ± 0.050V (at If)			
Offset voltage*2	Vof	≤ ± 0.040V (at If = 0A)							≤ ± 0.050V (at If = 0A)			
Output linearity (without offset)	εL	≤ ± 1% (at If)										
Power supply voltage	Vcc	± 12V (± 5%) ~ ± 15V (± 5%)										
Consumption current	Icc	± 14mA (typ) , ≤ ± 18mA										
di/dt Response time	tr	≤ 5μs (di/dt = If / μs)										
Thermal drift of gain	TcVo	≤ ± 0.1% / °C (Without Tc Vof)										
Thermal drift of offset	TcVof	≤ ± 1.5mV / °C										
Hysteresis error	Voh	≤ 25mV (at If = 0A → If → 0A)							≤ 40mV (at If = 0A → If → 0A)			
Insulation voltage	Vd	AC3000V for 1 minute (Sensing current 0.5mA) Primary ↔ Secondary										
Insulation resistance	Ris	≥ 500MΩ (at DC500V) Primary ↔ Secondary										
Ambient Operating temperature	Ta	- 30°C ~ + 80°C										
Ambient storage temperature	Ts	- 40°C ~ + 85°C										

* 1 Also operate at Vcc = ± 12V power supplies, measuring range reduced to 2.5 x If. * 2 Offset voltage value is after removal of core hysteresis.
* Please refer to the another sheet about conditions of UL Recognition.

DIMENSIONS (mm)

Lot No. [018P***D15-OP] The following, table references

Lot No. [018P***D15-OP] The following, table references

2-φA

4-□(0.25×0.5)

4-□(0.25×0.5)

Terminal number

- ① - Vcc (- 15V)
- ② GND
- ③ + Vcc (+ 15V)
- ④ Vout
- ⑤ Primary input current (+)
- ⑥ Primary input current (-)

Current	***	φA
3A	003	φ0.6
5A	005	φ0.8
10A	010	φ1.1
15A	015	φ1.4
20A	020	φ1.6
25A	025	φ1.6
30A	030	φ1.6
40A	040	Busbar
50A	050	Busbar
60A	060	Busbar

Note

- Unless otherwise specified, tolerances shall be ± 0.5mm
- Unit is [mm]

Weight: 8g

Magnetic Proportion System

L18P S05 SERIES

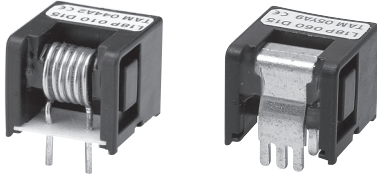

SPECIFICATIONS

Ta=25°C, RL=10kΩ, Vcc= +5V

Spec	Types	Types									
		L18P003S05	L18P005S05	L18P010S05	L18P015S05	L18P020S05	L18P025S05	L18P030S05	L18P040S05	L18P050S05	L18P060S05
Primary nominal current	If	3A	5A	10A	15A	20A	25A	30A	40A	50A	60A
Primary wire	φ	0.6mm	0.8mm	1.1mm	1.4mm	1.6mm			bus-bar 1.0 × 6.3		
Saturation current	If max	If × 1.5*1									
Rated output voltage	Vo	Vof + 1.5V ± 0.045V (at If)									
Offset voltage	Vof	Vcc/2 ± 0.035V (at If = 0A) *2									
Output linearity (without offset)	εL	≤ ± 1% (at If)									
Power supply voltage	Vcc	+ 5V ± 5%									
Consumption current	Icc	≤ 15mA									
di/dt Response time	tr	≤ 5μs (di/dt = If / μs)									
Thermal drift of gain	TcVo	≤ ± 2.0mV / °C (Without Tc Vof)									
Thermal drift of offset	TcVof	≤ ± 2.0mV / °C									
Hysteresis error	Voh	≤ 25mV (at If = 0A → If → 0A)									
Insulation voltage	Vd	AC3000V for 1 minute (Sensing current 0.5mA) Primary ↔ Secondary									
Insulation resistance	Ris	≥ 500M Ω (at DC500V) Primary ↔ Secondary									
Ambient Operating temperature	Ta	- 30°C ~ + 80°C									
Ambient storage temperature	Ts	- 40°C ~ + 85°C									

* 1 Vcc= + 5.0V (depending on Vcc) *2 Offset voltage value is after removal of core hysteresis. Please refer to the another sheet about conditions of UL Recognition.

DIMENSIONS (mm)

Terminal number

- GND
- GND
- + Vcc
- OUT
- + IN
- IN

Current	***	φA
3A	003	φ0.6
5A	005	φ0.8
10A	010	φ1.1
15A	015	φ1.4
20A	020	φ1.6
25A	025	φ1.6
30A	030	φ1.6

Note

- Unless otherwise specified, tolerances shall be ± 0.5mm
- Unit is [mm]

Terminal number

- GND
- GND
- + Vcc
- OUT
- + IN
- IN

Current	***
40A	040
50A	050
60A	060

Note

- Unless otherwise specified, tolerances shall be ± 0.5mm
- Unit is [mm]

Magnetic Proportion System

L18P S05R SERIES

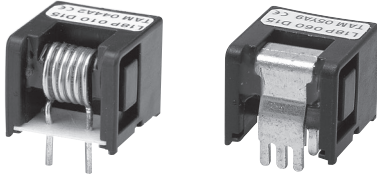

SPECIFICATIONS

Ta=25°C, RL=10kΩ, Vcc= +5V

Spec	Types	L18P003	L18P005	L18P010	L18P015	L18P020	L18P025	L18P030	L18P040	L18P050	L18P060
		S05R	S05R	S05R	S05R	S05R	S05R	S05R	S05R	S05R	S05R
Primary nominal current	If	3A	5A	10A	15A	20A	25A	30A	40A	50A	60A
Primary wire	φ	0.6mm	0.8mm	1.1mm	1.4mm	1.6mm			bus-bar 1.0 × 6.3		
Saturation current	If max	If × 3									
Rated output voltage	Vo	Vof + 0.625V ± 0.045V (at If)									
Offset voltage	Vof	2.5V ± 0.035V (at If = 0A) *1									
Output linearity (without offset)	εL	≤ ± 1% (at If)									
Power supply voltage	Vcc	+ 5V ± 5%									
Consumption current	Icc	≤ 15mA									
di / dt Response time	tr	≤ 5 μs (di/dt = If / μs)									
Thermal drift of gain	TcVo	≤ ± 0.1% / °C (Without Tc Vof)									
Thermal drift of offset	TcVof	≤ ± 1.0mV / °C									
Hysteresis error	Voh	≤ 25mV (at If = 0A → If → 0A)									
Insulation voltage	Vd	AC3000V for 1 minute (Sensing current 0.5mA) Primary ↔ Secondary									
Insulation resistance	Ris	≥ 500MΩ (at DC500V) Primary ↔ Secondary									
Ambient Operating temperature	Ta	- 30°C ~ + 80°C									
Ambient storage temperature	Ts	- 40°C ~ + 85°C									

* 1 Offset voltage value is after removal of core hysteresis. Please refer to the another sheet about conditions of UL Recognition.

DIMENSIONS (mm)

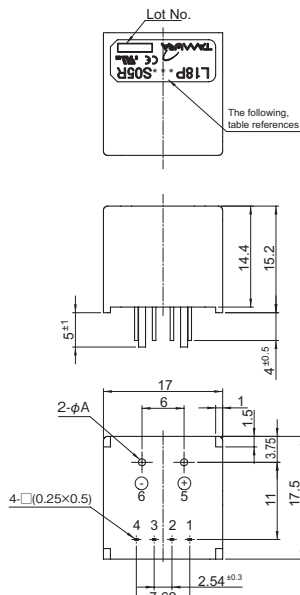

Terminal number

1. GND
2. GND
3. + Vcc
4. OUT
5. + IN
6. - IN

Current	***	φA
3A	003	φ0.6
5A	005	φ0.8
10A	010	φ1.1
15A	015	φ1.4
20A	020	φ1.6
25A	025	φ1.6
30A	030	φ1.6

Note

1. Unless otherwise specified, tolerances shall be ± 0.5mm
2. Unit is [mm]

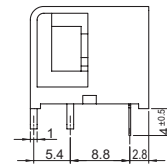
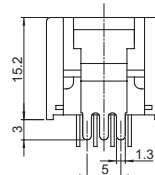
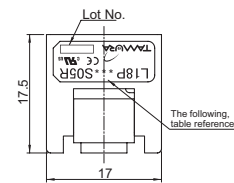

Terminal number

1. GND
2. GND
3. + Vcc
4. OUT
5. + IN
6. - IN

Current	***
40A	040
50A	050
60A	060

Note

1. Unless otherwise specified, tolerances shall be ± 0.5mm
2. Unit is [mm]

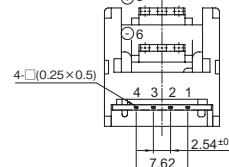

Magnetic Proportion System

L18P S12 SERIES

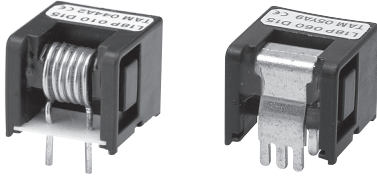

SPECIFICATIONS

Ta=25°C, RL=10kΩ, Vcc=+12V

Spec	Types	Types									
		L18P003S12	L18P005S12	L18P010S12	L18P015S12	L18P020S12	L18P025S12	L18P030S12	L18P040S12	L18P050S12	L18P060S12
Primary nominal current	If	3A	5A	10A	15A	20A	25A	30A	40A	50A	60A
Primary wire	φ	0.6mm	0.8mm	1.1mm	1.4mm	1.6mm		bus-bar 1.0 × 6.3			
Saturation current	If max	If × 1.25									
Rated output voltage	Vo	Vof + 1.5V ± 0.045V (at If)									
Offset voltage	Vof	2.5V ± 0.035V (at If = 0A) *1									
Output linearity (without offset)	εL	≤ ± 1% (at If)									
Power supply voltage	Vcc	+ 12V ± 5%									
Consumption current	Icc	≤ 15mA									
di/dt Response time	tr	≤ 5μs (di/dt = If / μs)									
Thermal drift of gain	TcVo	≤ ± 2.0mV / °C (Without Tc Vof)									
Thermal drift of offset	TcVof	≤ ± 2.0mV / °C									
Hysteresis error	Voh	≤ 25mV (at If = 0A → If → 0A)									
Insulation voltage	Vd	AC3000V for 1 minute (Sensing current 0.5mA) Primary ↔ Secondary									
Insulation resistance	Ris	≥ 500M Ω (at DC500V) Primary ↔ Secondary									
Ambient Operating temperature	TA	- 30°C ~ + 80°C									
Ambient storage temperature	TS	- 40°C ~ + 85°C									

* 1 Offset voltage value is after removal of core hysteresis. Please refer to the another sheet about conditions of UL Recognition.

DIMENSIONS (mm)

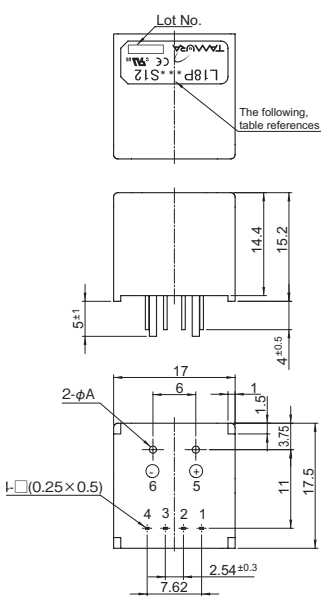

Terminal number

- GND
- GND
- + Vcc
- OUT
- + IN
- IN

Current	***	φA
3A	003	φ0.6
5A	005	φ0.8
10A	010	φ1.1
15A	015	φ1.4
20A	020	φ1.6
25A	025	φ1.6
30A	030	φ1.6

Note

- Unless otherwise specified, tolerances shall be ± 0.5mm
- Unit is [mm]

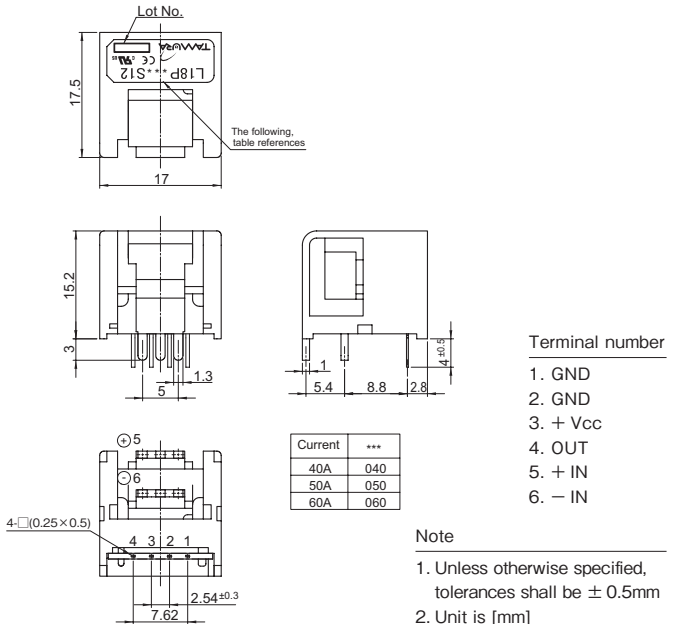

Terminal number

- GND
- GND
- + Vcc
- OUT
- + IN
- IN

Current	***	φA
40A	040	
50A	050	
60A	060	

Note

- Unless otherwise specified, tolerances shall be ± 0.5mm
- Unit is [mm]

Magnetic Proportion System, 2 Circuits Type

L07P D15 SERIES

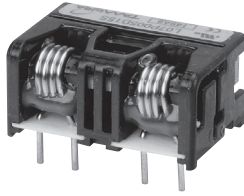

SPECIFICATIONS

Ta=25°C, RL=10kΩ, Vcc=±15V

Spec		Types						
		L07P003D15	L07P005D15	L07P010D15	L07P015D15	L07P020D15	L07P025D15	L07P030D15
Primary nominal current	If	3A	5A	10A	15A	20A	25A	30A
Saturation current	If max	If × 3						
Rated output voltage	Vo	4V ± 0.060V (at If)						
Offset voltage	Vof	≤ ± 0.060V (at If = 0A) *1						
Output linearity (0A ~ If)	εL	≤ ± 1% (at If)						
Power supply voltage	Vcc	± 15V ± 5%						
Consumption current	Icc	≤ ± 30mA						
di/dt Response time	tr	≤ 5μs (di / dt = If / μs) *2						
Thermal drift of gain	TcVo	≤ 0.1% / °C (Without Tc Vof)						
Thermal drift of offset	TcVof	≤ ± 2.5mV / °C						
Hysteresis error	Voh	≤ 30mV (at If = 0A → If → 0A)						
Insulation voltage	Vd	AC2000V for 1 minute (Sensing current 0.5mA) Primary ⇔ Secondary						
Insulation resistance	Ris	≥ 500MΩ (at DC500V) Primary ⇔ Secondary						
Ambient Operating temperature	Ta	- 30°C ~ + 80°C						
Ambient storage temperature	Ts	- 40°C ~ + 85°C						

* 1 Offset voltage value is after removal of core hysteresis. *2 Shall be each channel's value. Other channel's input current to be 0A. *Please refer to the another sheet about conditions of UL Recognition.

DIMENSIONS (mm)

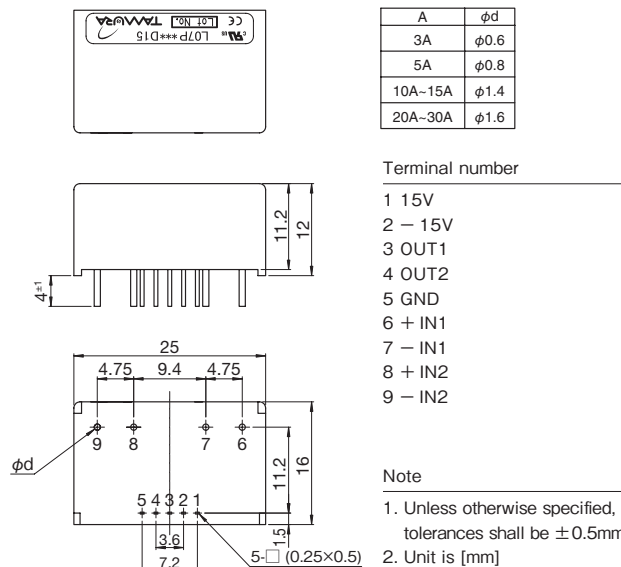

Magnetic Proportion System, 2 Circuits Type, Anti-Sulfurated

L07P D15S SERIES

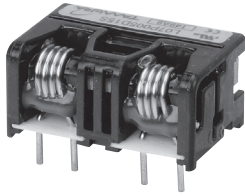

Introduction

Fluxgate system

Open loop

Closed loop

SPECIFICATIONS

Ta=25°C, RL=10kΩ, Vcc=±15V

Types		Types						
		L07P003D15S	L07P005D15S	L07P010D15S	L07P015D15S	L07P020D15S	L07P025D15S	L07P030D15S
Primary nominal current	If	3A	5A	10A	15A	20A	25A	30A
Saturation current	If max	If × 3						
Rated output voltage	Vo	4V ± 0.060V (at If)						
Offset voltage	Vof	≤ ± 0.060V (at If = 0A) * 1						
Output linearity (0A ~ If)	εL	≤ ± 1% (at If)						
Power supply voltage	Vcc	± 15V ± 5%						
Consumption current	Icc	≤ ± 30mA						
di/dt Response time	tr	≤ 5μs (di / dt = If / μs) * 2						
Thermal drift of gain	TcVo	≤ 0.1% / °C (Without Tc Vof)						
Thermal drift of offset	TcVof	≤ ± 2.5mV / °C						
Hysteresis error	Voh	≤ 30mV (at If = 0A → If → 0A)						
Insulation voltage	Vd	AC2000V for 1 minute (Sensing current 0.5mA) Primary ⇔ Secondary						
Insulation resistance	Ris	≥ 500MΩ (at DC500V) Primary ⇔ Secondary						
Ambient Operating temperature	TA	- 30°C ~ + 80°C						
Ambient storage temperature	TS	- 40°C ~ + 85°C						

* 1 Offset voltage value is after removal of core hysteresis. * 2 Shall be each channel's value. Other channel's input current to be 0A. * Please refer to the another sheet about conditions of UL Recognition. * Anti-Sulfurated (Used resistors : Gold internal Electrodes, PCB coating : HumiSeal®) *Reliability test High Temperature and High Humidity Operation Test (85°C, 85%RH, 1500h, N=11, Pass)

DIMENSIONS (mm)

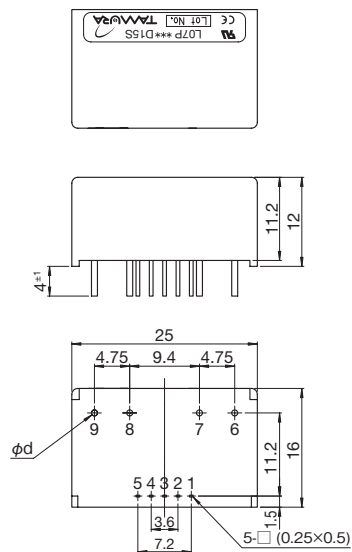

A	φd
3A	φ0.6
5A	φ0.8
10A-15A	φ1.4
20A-30A	φ1.6

- Terminal number
- + Vcc (+ 15V)
 - Vcc (- 15V)
 - Vout 1
 - Vout 2
 - GND
 - Primary input current 1 (+)
 - Primary input current 1 (-)
 - Primary input current 2 (+)
 - Primary input current 2 (-)

Weight:
8g

- Note
- Unless otherwise specified, tolerances shall be ± 0.5mm
 - Unit is [mm]

Magnetic Proportion System, 2 Circuits Type

L07P S05 SERIES

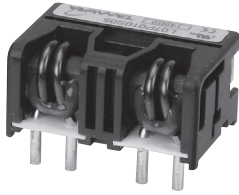

SPECIFICATIONS

Ta=25°C, RL=10kΩ, Vcc=+5V

Types		Types						
		L07P003S05	L07P005S05	L07P010S05	L07P015S05	L07P020S05	L07P025S05	L07P030S05
Primary nominal current	If	3A	5A	10A	15A	20A	25A	30A
Saturation current	If max	If × 1.5						
Rated output voltage	Vo	Vof + 1.250V ± 0.040V (at If)						
Offset voltage	Vof	Vcc/2 ± 0.040V *1 (at If = 0A)						
Output linearity (0A ~ If)	εL	≤ ± 1% (at If)						
Power supply voltage	Vcc	+ 5V ± 5%						
Consumption current	Icc	≤ 30mA						
di/dt Response time	tr	≤ 5μs (di / dt = If / μs) *2						
Thermal drift of gain	TcVo	≤ 2mV / °C (Without Tc Vof)						
Thermal drift of offset	TcVof	≤ ± 2.0mV / °C MAX.						
Hysteresis error	Voh	≤ 15mV (at If = 0A → If → 0A)						
Insulation voltage	Vd	AC2000V for 1 minute (Sensing current 0.5mA) Primary ⇔ Sacondary						
Insulation resistance	Ris	≥ 500MΩ (at DC500V) Primary ⇔ Sacondary						
Ambient Operating temperature	TA	- 30°C ~ + 80°C						
Ambient storage temperature	TS	- 40°C ~ + 85°C						

* 1 Offset voltage value is after removal of core hysteresis.
 * 2 Shall be each channel's value. Other channel's input current to be 0A. * Please refer to the another sheet about conditions of UL Recognition.

DIMENSIONS (mm)

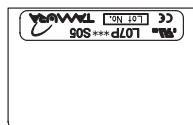

A	φd
3A	φ0.6
5A	φ0.8
10A~15A	φ1.4
20A~30A	φ1.6

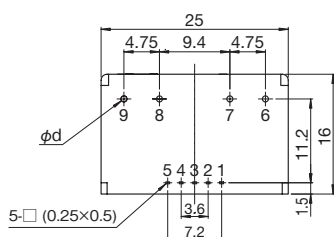
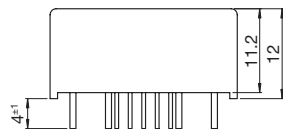

Terminal number

1. + 5V
2. NC
3. OUT1
4. OUT2
5. GND
6. + IN1
7. - IN1
8. + IN2
9. - IN2

Note

1. Unless otherwise specified, tolerances shall be ± 0.5mm
2. Unit is [mm]

Magnetic Proportion System

L12P D15 SERIES

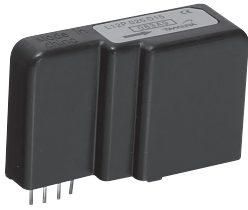

Introduction

Fluxgate system

Open loop

Closed loop

SPECIFICATIONS

Ta=25°C, RL=10kΩ, Vcc=±15V

Spec	Types	Symbol	L12P025D15
Primary nominal current		If	25A
Primary conductor specification		—	$\phi 1.4 \times 2^{*1}$
Continuous DC current		I _{con}	25A
Saturation current		If max	If × 3 ^{*2}
Rated output voltage		ε _L	4V ± 0.040V (at If)
Offset voltage		V _{of}	≤ ± 0.040V (at If = 0A) ^{*3}
Output linearity (0A ~ If)		V _{cc}	≤ ± 1% (at If)
Power supply voltage		V _{cc}	± 12V (± 5%) ~ ± 15V (± 5%)
Consumption current		I _{cc}	≤ 15mA
di/dt Response time		t _r	≤ 3μs (di/dt = If / μs)
Thermal drift of gain		T _c V _o	≤ ± 0.1% / °C (Without T _c V _{of})
Thermal drift of offset		T _c V _{of}	≤ ± 3.0mV / °C
Hysteresis error		V _{OH}	≤ 25mV (at If = 0A → If → 0A)
Insulation voltage		V _d	AC2500V for 1 minute (Sensing current 0.5mA) Primary ↔ Secondary
Insulation resistance		R _{is}	≥ 500MΩ (at DC500V) Primary ↔ Secondary
Ambient Operating temperature		T _A	- 30°C ~ + 80°C
Ambient storage temperature		T _S	- 40°C ~ + 85°C

* 1 Conductor terminals are soldered together. * 2 Also operate at Vcc = ± 12V power supplies, measuring range reduced to 2.5 x If.
 * 3 Offset voltage value is after removal of core hysteresis.

DIMENSIONS (mm)

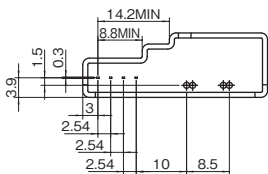
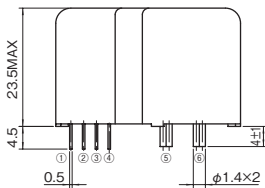
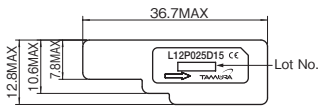

- Terminal number
- ① + Vcc (+ 15V)
 - ② - Vcc (- 15V)
 - ③ Vout
 - ④ GND
 - ⑤ Primary input current (+)
 - ⑥ Primary input current (-)

Weight: 20g

Note
 1. Unless otherwise specified, tolerances shall be ± 0.5mm
 2. Unit is [mm]

Magnetic Proportion System / Through Type and Busbar Type

L32P S05(B)FS SERIES

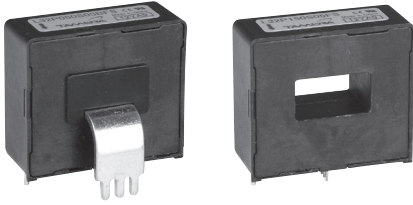

SPECIFICATIONS

Ta=25°C, RL=10kΩ, Vcc=+5.0V

Spec	Types	Symbol	Types					
			L32P050S05(B)FS	L32P100S05(B)FS	L32P150S05FS	L32P200S05FS	L32P300S05FS	L32P400S05FS
Primary nominal current	If		50A	100A	150A	200A	300A	400A
Saturation current	If max		≥ ± 150A	≥ ± 300A	≥ ± 450A	≥ ± 600A	≥ ± 600A	≥ ± 600A
Type	—		Through hole type : L32PxxxS05FS Bus bar type : L32PxxxS05BFS		Through hole type			
Reference Voltage	V ref		+ 2.495V ± 0.020V *1 (at Rref ≥ 1M Ω . Ouput impedance : typ 200 Ω)					
Rated output voltage	Vo		Vof + 0.625V ± 0.015 (at If)					
Offset voltage	Vof		Vref ± 0.025V (at If=0A) *2					
Output linearity (0A ~ If)	εL		± 0.5% (at 0A, 1/2If, If)					
Power supply voltage	Vcc		+ 5V ± 5%					
Consumption current	Icc		≤ 20mA					
di/dt Response time	tr		≤ 5μs (at di/dt=100A/μs)					
Reference Temperature Characteristic	TcVref		≤ ± 0.012%/°C					
Thermal drift of gain	TcVO		≤ ± 1.5mV/°C (Without TcVof)					
Thermal drift of offset (at If=0A)	TcVof		≤ ± 1.0mV/°C		≤ ± 0.6mV/°C		≤ ± 0.3mV/°C	
Hysteresis error (at 0A → If → 0A)	VOH		≤ ± 10mV		≤ ± 5.0mV		≤ ± 2.5mV	
Insulation voltage	Vd		AC2500V for 1 minute (Sensing current 0.5mA) Primary ↔ Secondary					
Insulation resistance	RiS		≥ 500M Ω (at DC500V) Primary ↔ Secondary					
Ambient Operating temperature	TA		- 40 ~ + 85°C					
Ambient storage temperature	TS		- 40 ~ + 85°C					

* 1 It is possible to change Vof with an external reference voltage (between 1.5V - 2.8V providing its ability to sink or source approximately 5 mA.) . If the external reference voltage is not used, the Vref pin should be left unconnected. * 2 Offset voltage value is after removal of core hysteresis. * Please refer to the another sheet about conditions of UL Recognition. * Anti-Sulfurated (Used resistors : Gold internal Electrodes) * Ferrite core is used.

DIMENSIONS (mm)

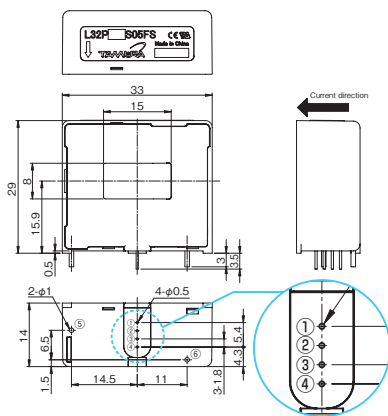

Terminal number

- ① Vcc (+5V)
- ② GND
- ③ Vout
- ④ Vref (IN/OUT)
- ⑤⑥ NC

Weight

22g

Note

- 1. Unless otherwise specified, tolerances shall be ±0.5mm
- 2. Unit is [mm]

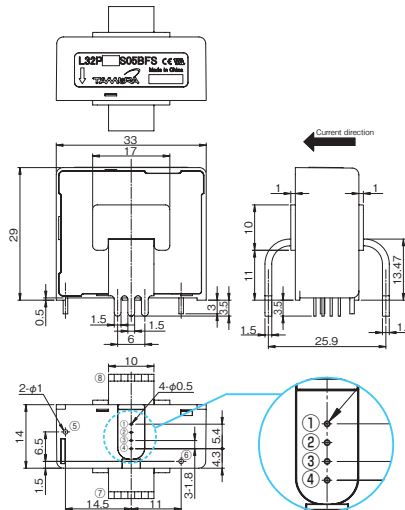

Terminal number

- ① Vcc (+5V)
- ② GND
- ③ Vout
- ④ Vref (IN/OUT)
- ⑤⑥ NC
- ⑦ Primary input current (+)
- ⑧ Primary input current (-)

Weight

30g

Note

- 1. Unless otherwise specified, tolerances shall be ±0.5mm
- 2. Unit is [mm]

Magnetic Proportion System / Through Type

L08P IPV/W/IPVW SERIES

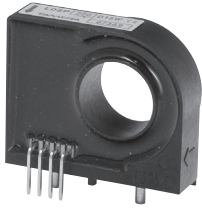

ABSOLUTE MAXIMUM RATINGS

Parameters	Symbol	Unit	Value	Comment
Supply voltage	Vcc	V	± 18V	

ISOLATION CHARACTERISTICS

Parameters	Symbol	Unit	Value	Comment
Insulation voltage	Vd	—	AC2500V, for 1minute (Sensing current 0.5mA)	Primary ⇔ Secondary
Insulation resistance	R _{IS}	—	≥ 500M Ω (at DC500V)	Primary ⇔ Secondary
Case material	—	—	UL94 V-0	

ENVIRONMENTAL AND MECHANICAL CHARACTERISTICS

Parameters	Symbol	Unit	Value			Comment
			MIN	TYP	MAX	
Ambient operating temperature	T _A	°C	- 40		+ 80	
Ambient storage temperature	T _S	°C	- 40		+ 85	
Mass	m	g		22		

SPECIFICATIONS

Ta=+25°C, R_L=10kΩ, Vcc=±15V

Parameters	Symbol	Unit	Value			Comment
			MIN	TYP	MAX	
Primary nominal current	L08P050D15IPV	I _{PN}	A		50	
	L08P100D15IPV				100	
	L08P150D15IPV				150	
	L08P200D15W				200	
	L08P300D15IPVW				300	
	L08P400D15IPVW				400	
	L08P500D15IPVW				500	
Primary current, measuring range * 1	L08P050D15IPV	I _{PM}	A	150		
	L08P100D15IPV			300		
	L08P150D15IPV			450		
	L08P200D15W			600		
	L08P300D15IPVW			600		
	L08P400D15IPVW			600		
	L08P500D15IPVW			600		

SPECIFICATIONS

Ta=+25°C, R_L=10kΩ, V_{cc}=±15V

Parameters	Symbol	Unit	Value			Comment	
			MIN	TYP	MAX		
Supply voltage	V _{cc}	V	±12(±5%)	±15(±5%)			
Consumption current	I _{cc}	mA		14	20		
Rated output voltage	V _o	V	3.960	4.000	4.040	at I _{PN}	
Offset voltage * 2	V _{of}	V	-0.030	0.000	+0.030	at I _{PN} = 0A	
Hysteresis error	V _{OH}	mV			± 20	at 0A → I _{PN} → 0A	
Thermal drift of gain	TcV _o	%/°C			± 0.05	Without TcV _{of}	
Thermal drift of V _{of}	L08P050D15IPV	TcV _{of}	mV/°C			± 2	at I _{PN} = 0A
	L08P100D15IPV					± 1	
	L08P150D15IPV					± 1	
	L08P200D15W					± 1	
	L08P300D15IPVW					± 1	
	L08P400D15IPVW					± 1	
	L08P500D15IPVW					± 1	
Linearity error (0A ~ I _{PN})	ε _L	%	-1		+1		
Response time (@70% of I _{PN} - 70% of V _o)	t _r	μs			3	di/dt=100A/μs	
Response time (@10% of I _{PN} - 90% of V _o)	L08P050D15IPV	t _r	μs			5	di/dt=100A/μs
	L08P100D15IPV					5	
	L08P150D15IPV					5	
	L08P200D15W					5	
	L08P300D15IPVW					5	
	L08P400D15IPVW					5	
	L08P500D15IPVW					8	
Response time (@10% of 250A - 90% of 2V)	L08P500D15IPVW	t _r	μs			7	di/dt=100A/μs

*1 If the product of 200A or less operate at V_{cc} = ± 12V power supplies, measuring range reduced to 2.5 x I_{PN}.
 *2 Offset voltage value is after removal of core hysteresis.

STANDARDS

EN62477-1:2012 and EN62477-1:2012/A11:2014

CONNECTION

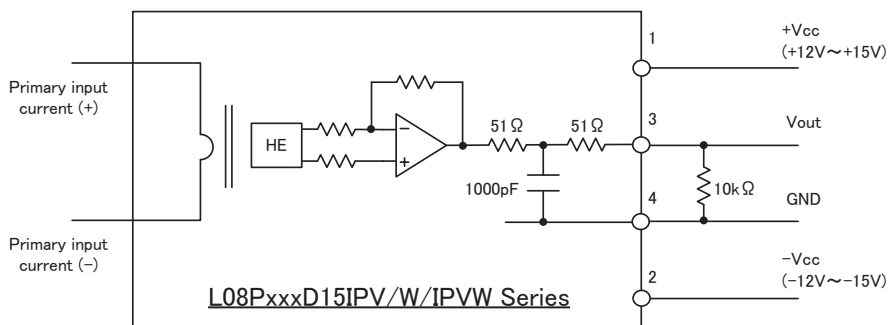

DIMENSIONS (mm)

L08PxxxD15IPV

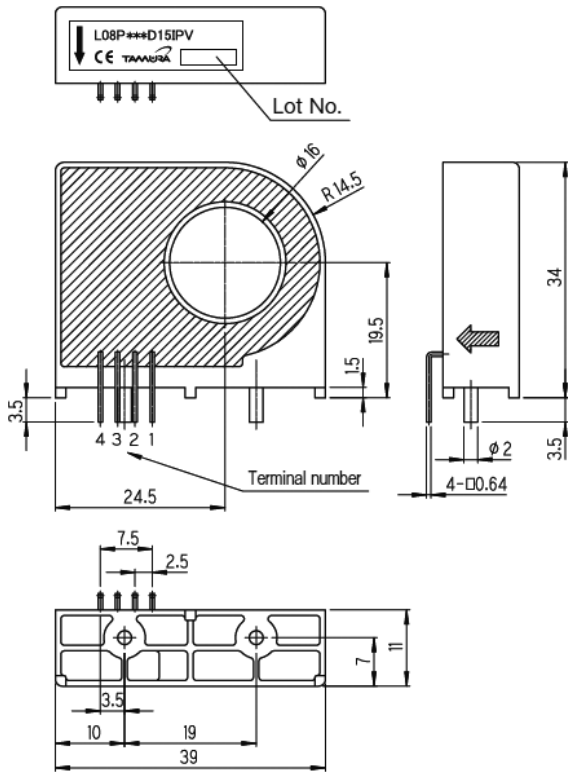

L08PxxxD15W/IPVW

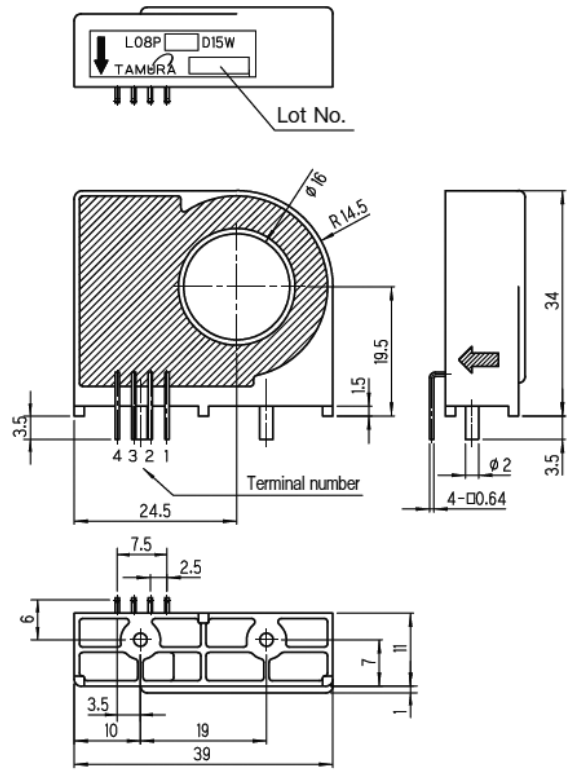

- Terminal number
- 1 + Vcc (+ 15V)
 - 2 - Vcc (- 15V)
 - 3 Vout
 - 4 GND

Note

1. Unless otherwise specified, tolerances shall be $\pm 0.5\text{mm}$

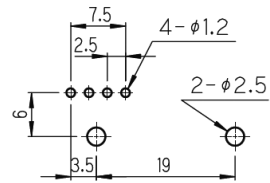

Circuit board hole dimension (View of solder surface)

Magnetic Proportion System / Through Type

L01Z SERIES

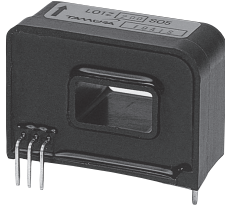

SPECIFICATIONS

Ta=25°C, RL=10kΩ, Vcc=+5V

Spec	Types	L01Z050S05	L01Z100S05	L01Z150S05	L01Z200S05	L01Z300S05	L01Z400S05	L01Z500S05	L01Z600S05
		Primary nominal current	If	50AT	100AT	150AT	200AT	300AT	400AT
Saturation current	If max	If × 1.25							
Rated output voltage	Vo	Vref + 1.5V ± 0.045V (at If)	Vref + 1.5V ± 0.035V (at If)						
Saturation output voltage	Vo min/max	Vo min ≤ 0.5V, 4.5V ≤ Vo max							
Offset voltage *1	Vof	Vref ± 0.035V (at If = 0A)	Vref ± 0.030V (at If = 0A)						
Output linearity (0A ~ If)	εL	≤ ± 1% (at If)							
Power supply voltage	Vcc	+ 5V ± 2%							
Consumption current	Icc	≤ 15mA							
di/dt Response time	tr	≤ 10μs (di/dt = 100A / μs)							
Thermal drift of gain	TcVo	≤ ± 2mV / °C (Without Tc Vof)	≤ ± 1.5mV / °C (Without Tc Vof)						
Thermal drift of offset	TcVof	≤ ± 2mV / °C	≤ ± 1mV / °C						
Hysteresis error	Voh	≤ 8mV (at If = 0A → If → 0A)			≤ 4mV (at If = 0A → If → 0A)		≤ 6mV (at If = 0A → If → 0A)		
Insulation voltage	Vd	AC2500V for 1 minute (Sensing current 0.5mA) inside of through hole ⇔ terminal							
Insulation resistance	Ris	≥ 500MΩ (at DC500V) inside of through hole ⇔ terminal							
Ambient Operating temperature	Ta	- 20°C ~ + 80°C							
Ambient storage temperature	Ts	- 40°C ~ + 85°C							

* 1 Vref=Vcc/2

DIMENSIONS (mm)

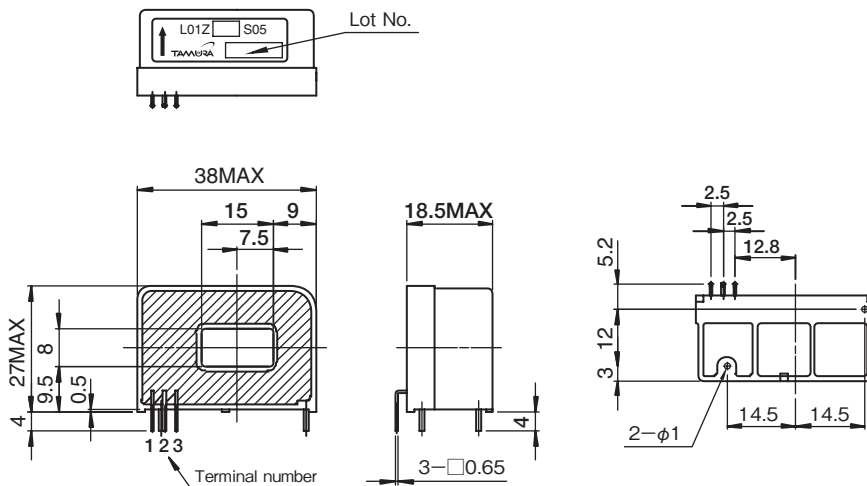

Terminal number

- 1 Vout
- 2 GND
- 3 + Vcc (+ 5V)

Weight:

45g

Note

Unless otherwise specified, tolerances shall be ± 0.5mm

Magnetic Proportion System / Through Type, Non ratiometric output, Vref-OUT/IN mode, $\Delta V_{out} = 800mV @ I_{PN}$

LA37S S05 SERIES



[STANDARDS]
 •UL508
 •CSA C22.2 No.14-18
 •EN 62477-1



ABSOLUTE MAXIMUM RATINGS

Parameters	Symbol	Unit	Value	Comment
Supply voltage	V_{CC}	V	7.2	
Primary conductor temperature	—	°C	120	
ESD (HBM : Human Body Model)	V_{ESD}	kV	2	C=100 pF, R=1.5 kΩ

ISOLATION CHARACTERISTICS

Parameters	Symbol	Unit	Value	Comment
Insulation voltage	V_d	—	AC3300V, for 1minute (Sensing current 0.5mA)	Primary ⇔ Secondary
Impulse withstand voltage	V_w	kV	6.0	Primary ⇔ Secondary Input waveform : · Front time 1.2μs · Time to half value 50μs · single
Insulation resistance	R_{is}	—	≥ 500MΩ (at DC500V)	Primary ⇔ Secondary
Clearance distance	d_{cl}	—	5.5 mm (MIN)	Primary ⇔ Secondary
Creepage distance	d_{cp}	—	5.5 mm (MIN)	Primary ⇔ Secondary
Case material	—	—	UL94 V-0	
Comparative Tracking Index; (CTI)	CTI	V	600 (group I)	

ENVIRONMENTAL AND MECHANICAL CHARACTERISTICS

Parameters	Symbol	Unit	Value			Comment
			MIN	TYP	MAX	
Ambient operating temperature * 1	T_A	°C	- 40		+ 105	
Ambient storage temperature	T_S	°C	- 40		+ 105	
Mass	m	g		60		
Internal magnetic core	—	—	Silicon steel			

* 1 Temperature of the connector should not exceed 105°C because the absolute maximum temperature of the connector is +105°C.

SPECIFICATIONS

T_A = +25°C R_L = 10 kΩ V_{cc}=+5V

Parameters		Symbol	Unit	Value			Comment
				MIN	TYP	MAX	
Primary nominal current	LA37S050S05*	I _{PN}	A		50		
	LA37S100S05*				100		
	LA37S200S05*				200		
	LA37S300S05*				300		
	LA37S400S05*				400		
	LA37S500S05*				500		
	LA37S600S05*				600		
Primary current, measuring range * 1	LA37S050S05*	I _{PM}	A	- 125		125	V _{cc} > 4.8V Ref OUT mode
	LA37S100S05*			- 250		250	
	LA37S200S05*			- 500		500	
	LA37S300S05*			- 750		750	
	LA37S400S05*			- 1000		1000	
	LA37S500S05*			- 1200		1200	
	LA37S600S05*			- 1200		1200	
Supply voltage	V _{cc}	V	4.5	5.0	5.5		
Consumption current	I _{cc}	mA		16	23	@ I _p = 0A, I _{cc} = 16+ V _{out} / R _L	
Load resistance	R _L	kΩ	4.7	10			
Internal reference voltage (output)	V _{ref1}	V	2.48	2.50	2.52	Ref OUT mode	
External reference input voltage	V _{ref2}	V	0.50		2.65	Ref IN mode	
Reference source current	I _{ref}	mA	0.5	0.7	1.0	V _{ref} to GND. See "support docu..." section.	
Reference sink current	I _{ref}	mA		5	10	V _{ref} to V _{cc} . See "support docu..." section.	
Output voltage range (@ I _{PM})	V _{out} -V _{ref}	V	- 2		2	Ref OUT mode	
Internal output resistance of V _{ref}	R _{ref}	Ω	150	200	300	Inside LA37SxxxS05 * .	
Internal output resistance of V _{out}	R _{out}	Ω		2	5	Inside LA37SxxxS05 * .	
Electrical offset voltage (@ I _p =0 A) * 2	V _{oe}	mV	- 5		5	V _{out} -V _{ref} at V _{ref} =2.5V	
Magnetic offset voltage	V _{OH}	mV	- 3.2		3.2	@ 0A → I _{PN} → 0A	
Temperature drift of reference voltage (at I _p =0 A)	V _{refT}	mV	- 10		10	@T _A = - 40°C~ 105°C	
Temperature drift of offset voltage (at I _p =0 A)	V _{oeT}	mV	- 10		10	@T _A = - 40°C~ 105°C	
Theoretical sensitivity	LA37S050S05*	G _{th}	mV/A		16.00		800mV @ I _{PN} V _{out} = V _{ref} + V _{oe} + (G _{th} × I _p)
	LA37S100S05*				8.00		
	LA37S200S05*				4.00		
	LA37S300S05*				2.67		
	LA37S400S05*				2.00		
	LA37S500S05*				1.60		
	LA37S600S05*				1.33		
Sensitivity error * 3	ε _G	%	- 1.0		1.0	@ I _{PN}	
Temperature drift of sensitivity	G _T	%	- 3.0		3.0	@T _A = - 40°C~ 105°C	

* 1 Measurement condition : Primary conductor cross sectional area is as same as through hole, and penetration with 1 turn in through hole.

* 2 Electrical offset voltage value is after removal of magnetic offset voltage (core hysteresis).

* 3 Sensitivity error is factory inspection value. MAX and MIN are values of ± 3 σ .

SPECIFICATIONS

T_A = +25°C RL = 10 kΩ V_{CC}=+5V

Parameters		Symbol	Unit	Value			Comment
				MIN	TYP	MAX	
Linearity error	@0A ~ I _{PN}	ε _L	%	-0.5		0.5	
	@0A ~ I _{PM}			-1.0		1.0	
Reaction time (@ 10 % of I _{PN}) * 1		t _{ra}	μs			3.0	di/dt=100A / μs
Response time (@ 90 % of I _{PN}) * 1	LA37S050S05*	tr	μs			4.0	di/dt=100A / μs
	Others					3.5	
Frequency bandwidth		BW	kHz		100		@ - 3dB
Output voltage noise	LA37S050S05*	V _{no}	mVpp		30		DC..20MHz
	LA37S100S05*				25		
	LA37S200S05*				20		
	LA37S300S05*				20		
	LA37S400S05*				25		
	LA37S500S05*				20		
	LA37S600S05*				20		
Accuracy * 4	T _A =25°C	X1	% of I _{PN}	-1.50		1.50	@ I _{PN}
	T _A =105°C	X2	% of I _{PN}	-5.75		5.75	

* 1 Measurement condition : Primary conductor cross sectional area is as same as through hole, and penetration with 1 turn in through hole.

* 4 Accuracy formula is following Accuracy X1 = ε_G + ε_L
Accuracy X2 = X1 + (V_{oeT} / 800 × 100) + G_T

STANDARDS



EN62477-1:2012, EN62477-1:2012/A1:2017 and EN62477-1:2012/A11:2014
Rated voltage 300V, CAT III, PD2, Reinforced isolation, non uniform field



UL508, CSA C22.2 No.14-18 (UL FILE No. E243511)
Rated voltage 600V, PD2

※ Please refer to the another sheet about conditions of UL Recognition.

SUPPORT DOCUMENTATION

Reference voltage

The Ref pin can be used as Ref OUT mode and/or Ref IN mode.

<Ref OUT mode>

The 2.5 V internal reference is used by the transducer as the reference point for bipolar measurements.

<Ref IN mode>

An external reference voltage is connected to the Ref pin. This voltage is specified in the range 0.5 to 2.65 V, its voltage is used as the offset voltage at the measurement.

The following graphs (Fig 1) show the output voltage (@ $I_p = 0A$) and the reference input / output current due to the external reference voltage value V_{ref2} .

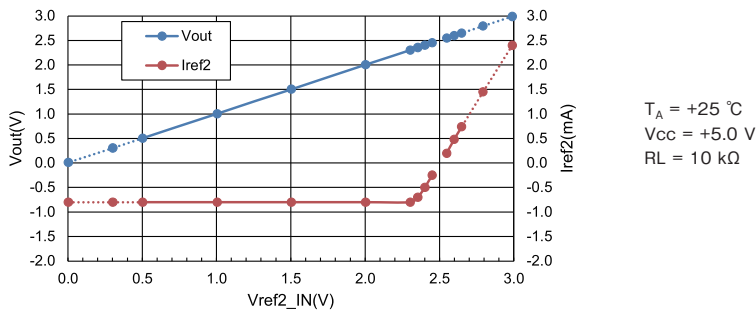
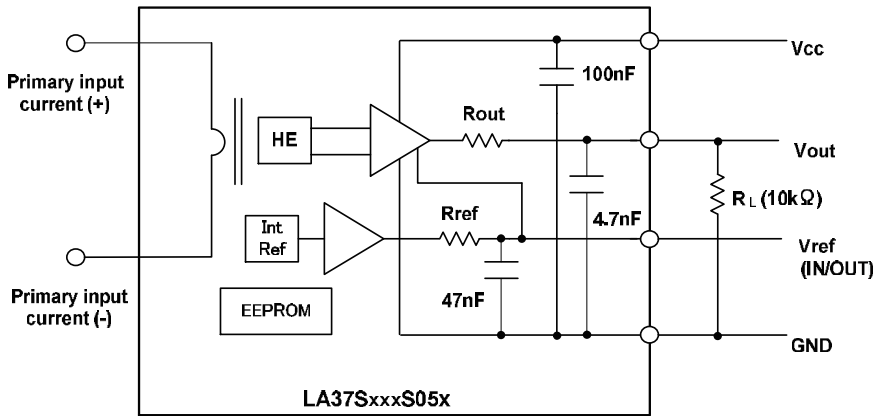

Fig 1 : V_{ref2} input voltage vs Output voltage and I_{ref2} (= V_{ref2} current) (Typical performance)

CONNECTION



< Notice >

Sufficient capacitors are built into the product for the purpose of reducing output noise. Do not attach external capacitors to the Vout and Vref terminals.

DIMENSIONS (mm)

LA37SxxxS05M(M-A) Series

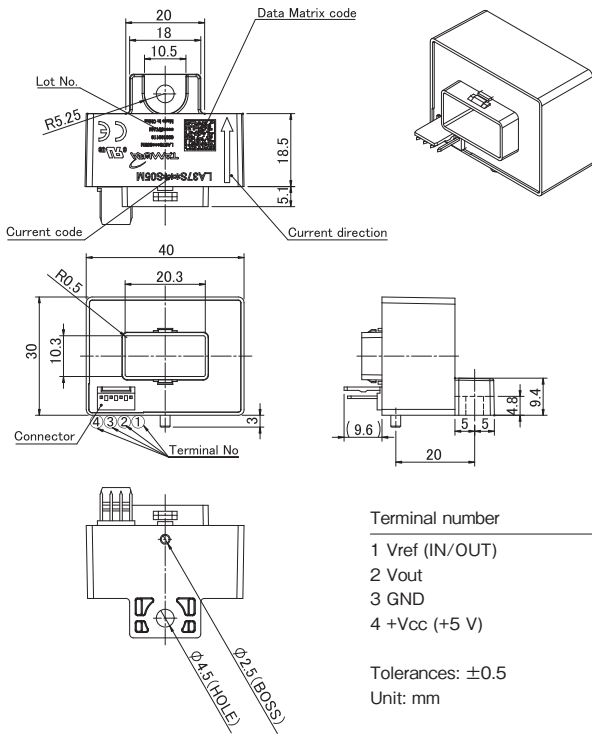

LA37SxxxS05J Series

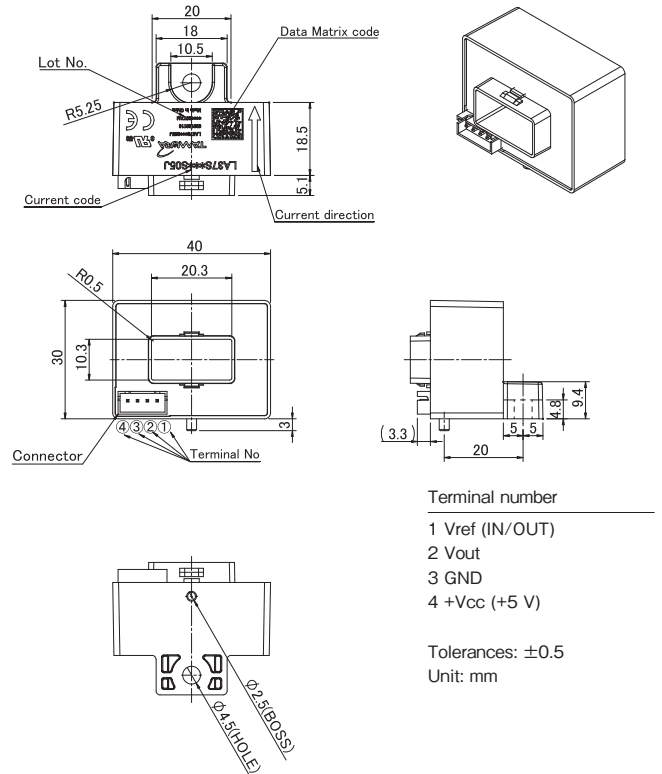

- Recommended fastening screw type : M4 with flat washer and spring washer
- Recommended fastening torque : < 1.5 N · m

Note
It is different from how to put the pin numbering of connector manufacturer (JST). It is matched to the Molex type.

Order number and Connector number (terminal plating)

Types		Connector			
		Manufacturer	Part Number	Old Part Number	Plating of terminal
LA37SxxxS05J	Standard	JST	B4B-XH-A-G	—	Au
LA37SxxxS05M	Standard	Molex	22-04-1041	5045-04A	Sn
LA37SxxxS05M-A	Build to Order		22-11-1041	5045-04AG	Au

- * Rated current (3 figures)
- * As for the LA37SxxxS05M series of a gold-plated connector, ' -A ' attaches to the end of the product name.
- * The pin numbers of LA37SxxxD15J are different from those of the connector maker (JST). It is matched to the Molex type.

Magnetic Proportion System / Through Type, Non ratiometric output, Vref-OUT/IN mode, $\Delta V_{out} = 625mV @ I_{PN}$

LA37S S05K SERIES



[STANDARDS]
 •UL508
 •CSA C22.2 No.14-18
 •EN 62477-1



ABSOLUTE MAXIMUM RATINGS

Parameters	Symbol	Unit	Value	Comment
Supply voltage	V_{CC}	V	7.2	
Primary conductor temperature	—	°C	120	
ESD (HBM : Human Body Model)	V_{ESD}	kV	2	C=100 pF, R=1.5 kΩ

ISOLATION CHARACTERISTICS

Parameters	Symbol	Unit	Value	Comment
Insulation voltage	V_d	—	AC3300V, for 1minute (Sensing current 0.5mA)	Primary ⇔ Secondary
Impulse withstand voltage	V_w	kV	6.0	Primary ⇔ Secondary Input waveform : · Front time 1.2μs · Time to half value 50μs · single
Insulation resistance	R_{is}	—	≥ 500MΩ (at DC500V)	Primary ⇔ Secondary
Clearance distance	d_{cl}	—	5.5 mm (MIN)	Primary ⇔ Secondary
Creepage distance	d_{cp}	—	5.5 mm (MIN)	Primary ⇔ Secondary
Case material	—	—	UL94 V-0	
Comparative Tracking Index; (CTI)	CTI	V	600 (group I)	

ENVIRONMENTAL AND MECHANICAL CHARACTERISTICS

Parameters	Symbol	Unit	Value			Comment
			MIN	TYP	MAX	
Ambient operating temperature * 1	T_A	°C	- 40		+ 105	
Ambient storage temperature	T_S	°C	- 40		+ 105	
Mass	m	g		60		
Internal magnetic core	—	—	Silicon steel			

* 1 Temperature of the connector should not exceed 105°C because the absolute maximum temperature of the connector is +105°C.

SPECIFICATIONS

T_A = +25°C RL = 10 kΩ Vcc=+5V

Parameters		Symbol	Unit	Value			Comment
				MIN	TYP	MAX	
Primary nominal current	LA37S050S05K*	I _{PN}	A		50		
	LA37S100S05K*				100		
	LA37S200S05K*				200		
	LA37S300S05K*				300		
	LA37S400S05K*				400		
	LA37S500S05K*				500		
	LA37S600S05K*				600		
Primary current, measuring range * 1	LA37S050S05K*	I _{PM}	A	- 150		150	Vcc > 4.8V Ref OUT mode
	LA37S100S05K*			- 300		300	
	LA37S200S05K*			- 600		600	
	LA37S300S05K*			- 900		900	
	LA37S400S05K*			- 1200		1200	
	LA37S500S05K*			- 1200		1200	
	LA37S600S05K*			- 1200		1200	
Supply voltage	Vcc	V	4.5	5.0	5.5		
Consumption current	Icc	mA		16	23	@ I _p = 0A, Icc = 16+ Vout / RL	
Load resistance	R _L	kΩ	4.7	10			
Internal reference voltage (output)	Vref1	V	2.48	2.50	2.52	Ref OUT mode	
External reference input voltage	Vref2	V	0.50		2.65	Ref IN mode	
Reference source current	Iref	mA	0.5	0.7	1.0	Vref to GND. See "support docu..." section.	
Reference sink current	Iref	mA		5	10	Vref to Vcc. See "support docu..." section.	
Output voltage range (@ I _{PM})	Vout-Vref	V	- 2		2	Ref OUT mode	
Internal output resistance of Vref	Rref	Ω	150	200	300	Inside LA37SxxxS05K * .	
Internal output resistance of Vout	Rout	Ω		2	5	Inside LA37SxxxS05K *	
Electrical offset voltage (@ I _p =0 A) * 2	Voe	mV	- 5		5	Vout-Vref at Vref=2.5V	
Magnetic offset voltage	V _{OH}	mV	- 2.5		2.5	@ 0A → I _{PN} → 0A	
Temperature drift of reference voltage (at I _p =0 A)	Vref _T	mV	- 10		10	@T _A = - 40°C~ 105°C	
Temperature drift of offset voltage (at I _p =0 A)	Voe _T	mV	- 10		10	@T _A = - 40°C~ 105°C	
Theoretical sensitivity	LA37S050S05K*	Gth	mV/A		12.50		625mV @ I _{PN} Vout = Vref + Voe + (Gth × I _p)
	LA37S100S05K*				6.250		
	LA37S200S05K*				3.125		
	LA37S300S05K*				2.083		
	LA37S400S05K*				1.563		
	LA37S500S05K*				1.250		
	LA37S600S05K*				1.042		
Sensitivity error * 3	ε _G	%	- 1.3		1.3	@ I _{PN}	
Temperature drift of sensitivity	G _T	%	- 3.0		3.0	@T _A = - 40°C~ 105°C	

* 1 Measurement condition : Primary conductor cross sectional area is as same as through hole, and penetration with 1 turn in through hole.

* 2 Electrical offset voltage value is after removal of magnetic offset voltage (core hysteresis).

* 3 Sensitivity error is factory inspection value. MAX and MIN are values of ± 3 σ .

SPECIFICATIONS

T_A = +25°C RL = 10 kΩ V_{CC}=+5V

Parameters		Symbol	Unit	Value			Comment
				MIN	TYP	MAX	
Linearity error	@0A ~ I _{PN}	ε _L	%	-0.5		0.5	
	@0A ~ I _{PM}			-1.0		1.0	
Reaction time (@ 10 % of I _{PN}) * 1		t _{ra}	μs			3.0	di/dt=100A / μs
Response time (@ 90 % of I _{PN}) * 1	LA37S050S05K*	tr	μs			4.0	di/dt=100A / μs
	Others					3.5	
Frequency bandwidth		BW	kHz		100		@ - 3dB
Output voltage noise	LA37S050S05K*	V _{no}	mVpp		30		DC..20MHz
	LA37S100S05K*				25		
	LA37S200S05K*				20		
	LA37S300S05K*				20		
	LA37S400S05K*				25		
	LA37S500S05K*				20		
	LA37S600S05K*				20		
Accuracy * 4	T _A =25°C	X1	% of I _{PN}	-1.8		1.8	@ I _{PN}
	T _A =105°C	X2	% of I _{PN}	-6.4		6.4	

* 1 Measurement condition : Primary conductor cross sectional area is as same as through hole, and penetration with 1 turn in through hole.

* 4 Accuracy formula is following
 Accuracy X1 = ε_G + ε_L
 Accuracy X2 = X1 + (V_{oeT} / 625 × 100) + G_T

STANDARDS



EN62477-1:2012, EN62477-1:2012/A1:2017 and EN62477-1:2012/A11:2014
 Rated voltage 300V, CAT III, PD2, Reinforced isolation, non uniform field



UL508, CSA C22.2 No.14-18 (UL FILE No. E243511)
 Rated voltage 600V, PD2

※ Please refer to the another sheet about conditions of UL Recognition.

SUPPORT DOCUMENTATION

Reference voltage

The Ref pin can be used as Ref OUT mode and/or Ref IN mode.

<Ref OUT mode>

The 2.5 V internal reference is used by the transducer as the reference point for bipolar measurements.

<Ref IN mode>

An external reference voltage is connected to the Ref pin. This voltage is specified in the range 0.5 to 2.65 V, its voltage is used as the offset voltage at the measurement.

The following graphs (Fig 1) show the output voltage (@ $I_p = 0A$) and the reference input / output current due to the external reference voltage value Vref2.

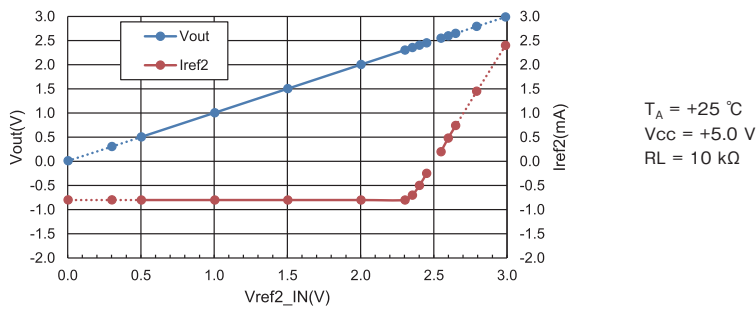
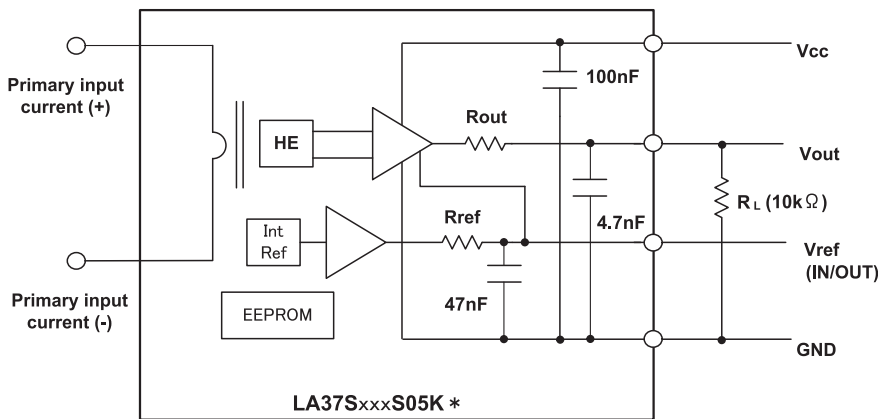

Fig 1 : Vref2 input voltage vs Output voltage and Iref2 (= Vref2 current) (Typical performance)

CONNECTION



< Notice >

Sufficient capacitors are built into the product for the purpose of reducing output noise. Do not attach external capacitors to the Vout and Vref terminals.

DIMENSIONS (mm)

LA37SxxxS05KM(M-A) Series

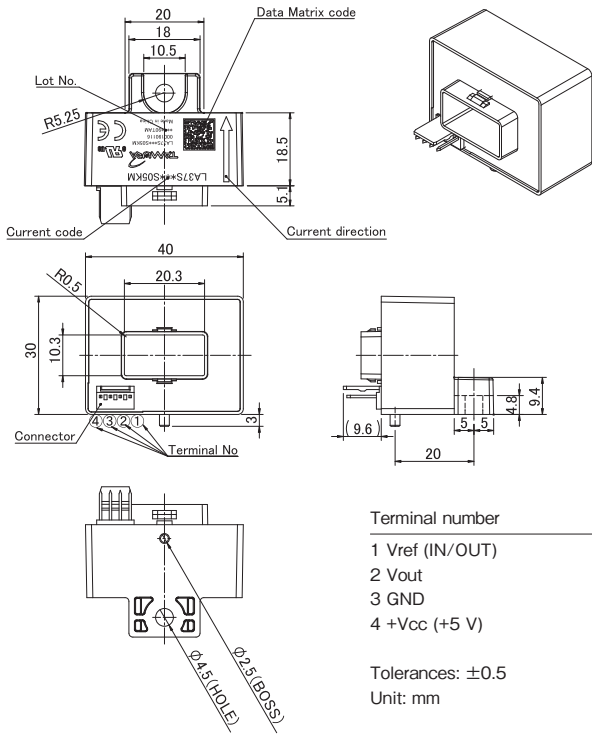

LA37SxxxS05KJ Series

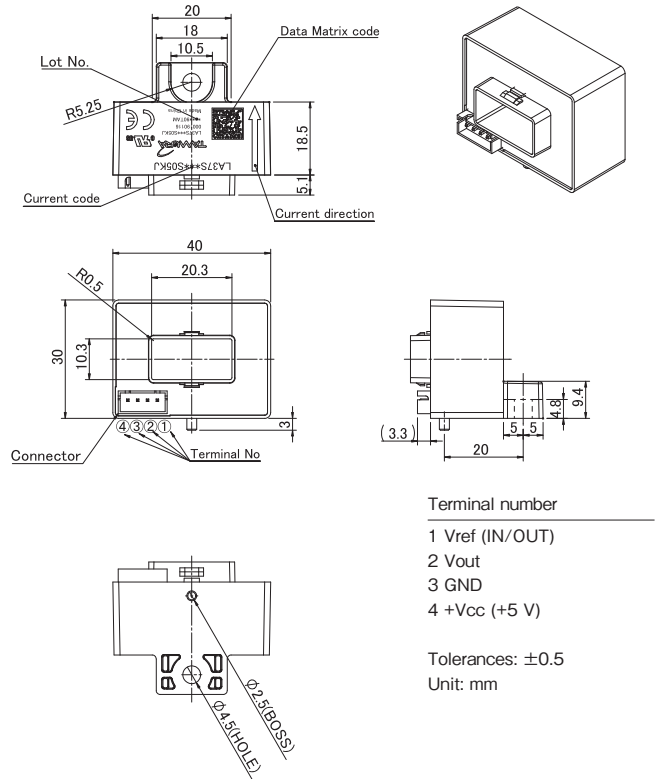

- Recommended fastening screw type : M4 with flat washer and spring washer
- Recommended fastening torque : < 1.5 N · m

Note
It is different from how to put the pin numbering of connector manufacturer (JST). It is matched to the Molex type.

Order number and Connector number (terminal plating)

Types		Connector			
		Manufacturer	Part Number	Old Part Number	Plating of terminal
LA37SxxxS05KJ	Standard	JST	B4B-XH-A-G	—	Au
LA37SxxxS05KM	Standard	Molex	22-04-1041	5045-04A	Sn
LA37SxxxS05KM-A	Build to Order		22-11-1041	5045-04AG	Au

- * Rated current (3 figures)
- * As for the LA37SxxxS05KM series of a gold-plated connector, ' -A ' attaches to the end of the product name.
- * The pin numbers of LA37SxxxS05KJ are different from those of the connector maker (JST). It is matched to the Molex type.

Magnetic Proportion System / Through Type

L37S S05 SERIES



ABSOLUTE MAXIMUM RATINGS

Parameters	Symbol	Unit	Value	Comment
Supply voltage	Vcc	V	+ 7V	

ISOLATION CHARACTERISTICS

Parameters	Symbol	Unit	Value	Comment
Insulation voltage	Vd	—	AC3300V, for 1minute (Sensing current 0.5mA)	Primary ⇔ Secondary
Impulse withstand voltage	Vw	kV	6.0	Primary ⇔ Secondary Input waveform : • Front time 1.2μs • Time to half value 50μs • single
Insulation resistance	R _{IS}	—	≥ 1000M Ω (at DC500V)	Primary ⇔ Secondary
Clearance distance * 1	d _{ci}	—	5.5mm (MIN)	Primary ⇔ Secondary
Creepage distance * 1	d _{cp}	—	6.0mm (MIN)	Primary ⇔ Secondary
Case material	—	—	UL94 V-0	
Comparative tracking index; (CTI)	CTI	V	200 (group IIIa)	
Application example	—	—	300V, CAT III, PD2	Reinforced isolation, non uniform field according to EN62477-1 : 2012 and EN62477-1 : 2012/A11 2014, IEC/EN 61010-1
	—	—	600V, CAT III, PD2	Basic isolation, non uniform field according to EN62477-1 : 2012 and EN62477-1 : 2012/A11 2014, IEC/EN 61010-1

* 1 Requirement distance according to safety standard UL508.

ENVIRONMENTAL AND MECHANICAL CHARACTERISTICS

Parameters	Symbol	Unit	Value			Comment
			MIN	TYP	MAX	
Ambient operating temperature	T _A	°C	- 40		+ 85	
Ambient storage temperature	T _S	°C	- 40		+ 85	
Mass	m	g		62		

SPECIFICATIONS

Ta=+25°C, RL=10kΩ, VCC=+5V

Parameters	Symbol	Unit	Value			Comment
			MIN	TYP	MAX	
Primary nominal current	L37S050S05 *	IPN	A		50	
	L37S100S05 *				100	
	L37S200S05 *				200	
	L37S300S05 *				300	
	L37S400S05 *				400	
	L37S500S05 *				500	
	L37S600S05 *				600	
Primary current, measuring range	L37S050S05 *	IPM	A	150		
	L37S100S05 *			300		
	L37S200S05 *			600		
	L37S300S05 *			900		
	L37S400S05 *			900		
	L37S500S05 *			900		
	L37S600S05 *			900		
Supply voltage	Vcc	V	4.75	5.00	5.25	
Consumption current	Icc	mA		15	20	
Reference voltage (output)	Vref1	V	2.475	2.495	2.515	at Ip = 0A
Reference voltage (input) * 1	Vref2	V	1.500		2.800	
Reference internal output resistance	Rref	Ω		200		
Reference internal output capacitance	Cref	nF		47		
Output voltage	Vo	V	Vof + 0.625V ± 0.015V			at IPN
Offset voltage * 2	Vof	V	Vref-0.020	Vref	Vref + 0.020V	at Ip = 0A
Hysteresis error	VOH	mV			± 7.5	at 0A → IPN → 0A
Temperature coefficient of Vref1	TcVref	ppm/K			± 190	at Ip = 0A
Temperature coefficient of Vo	TcVo	%/K			± 0.24	Without TcVof
Temperature coefficient of Vof	L37S050S05 *	TcVof	mV/K			± 1.0
	L37S100S05 *					± 1.0
	L37S200S05 *					± 1.0
	L37S300S05 *					± 0.3
	L37S400S05 *					± 0.3
	L37S500S05 *					± 0.3
	L37S600S05 *					± 0.3
Linearity error 1	εL1	%	- 0.5		+ 0.5	at Ip = 0A ~ IPN
Linearity error 2	εL2	%	- 1.0		+ 1.0	at Ip = 0A ~ IPM
Response time (@90% of If)	tr	μs			5	di/dt=100A/μs
Frequency bandwidth (at -3dB) * 4	BW	kHz	50			
Output voltage noise (DC · · · 10MHz)	Vno	mVpp			40	

* 1 It is possible to change Vof with an external reference voltage (between 1.5V - 2.8V providing its ability to sink or source approximately 5 mA.). If the external reference voltage is not used, the Vref pin should be left unconnected.

* 2 Offset voltage value is after removal of core hysteresis.

* 3 Measurement condition : Primary conductor cross sectional area is as same as through hole, and penetration with 1 turn in through hole.

* 4 Please derate input current to avoid excessive product heating. If you input current with high frequency band.

STANDARDS

EN62477-1:2012 and EN62477-1:2012/A11:2014 , EN50178 , IEC/EN 61010-1 , IEC/EN 62109-1 , UL508 (file No. E243511)

※ Please refer to the another sheet about conditions of UL Recognition.

CONNECTION

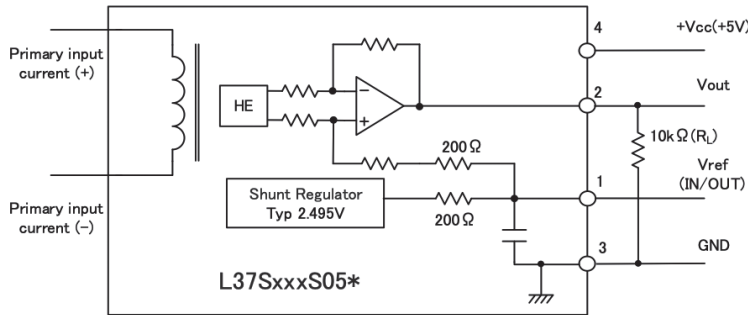

DIMENSIONS (mm)

L37SxxxS05M

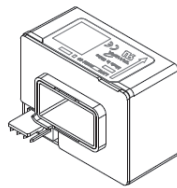
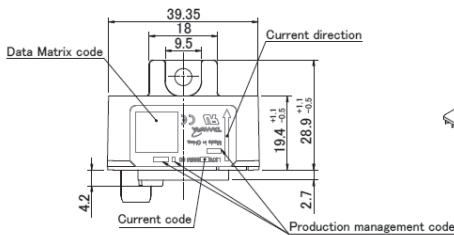

L37SxxxS05J

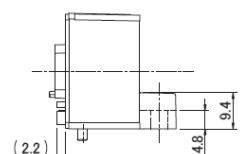
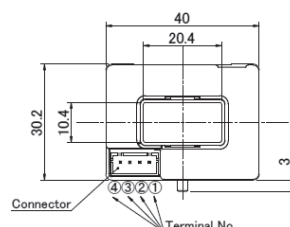
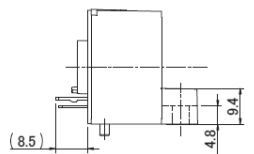
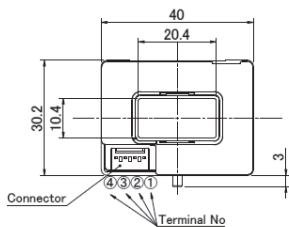
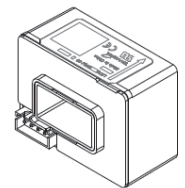
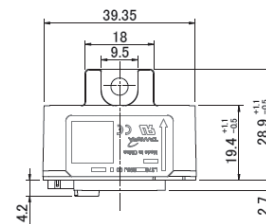

Terminal number

- 1 VREF
- 2 Vout
- 3 GND
- 4 +Vcc (+5V)

Note

Unless otherwise specified tolerances shall be ±0.5mm.

Note

It is different from how to put the pin numbering of connector manufacturer (JST). It changes to the expression of the Molex product.

Order number and Connector number (terminal plating)

Types		Connector			
		Manufacturer	Part Number	Old Part Number	Plating of terminal
L37SxxxS05J	Standard	JST	B4B-XH-A-G	—	Au
L37SxxxS05M	Standard	Molex	22-04-1041	5045-04A	Sn
L37SxxxS05M-A	Build to Order		22-11-1041	5045-04AG	Au

As for the L37SxxxS05M series of a gold-plated connector, 'A' attaches to the end of the product name.

Magnetic Proportion System / Through Type

L37S D15 SERIES



[STANDARDS]
 •UL508
 •EN 62477-1



ABSOLUTE MAXIMUM RATINGS

Parameters	Symbol	Unit	Value	Comment
Supply voltage	V _{CC}	V	± 18V	

ISOLATION CHARACTERISTICS

Parameters	Symbol	Unit	Value	Comment	
Insulation voltage	V _d	—	AC3600V, for 1minute (Sensing current 0.5mA)	Primary ⇔ Secondary	
Impulse withstand voltage	V _w	kV	6.6	Primary ⇔ Secondary Input waveform : • Front time 1.2μs • Time to half value 50μs • single	
Insulation resistance	R _{IS}	—	≥ 1000M Ω (at DC500V)	Primary ⇔ Secondary	
Clearance distance (Requirement distance according to safety standard)	d _{Cl}	—	5.5mm (MIN)	Primary ⇔ Secondary	
Creepage distance (Requirement distance according to safety standard)	d _{Cp}	—	6.0mm (MIN)	Primary ⇔ Secondary	
Case material	—	—	UL94 V-0		
Filler material	—	—	UL94 V-0		
Comparative tracking index; (CTI)	Case	CTI	V	200 (group IIIa)	
	Filler	CTI	V	600 (group I)	

ENVIRONMENTAL AND MECHANICAL CHARACTERISTICS

Parameters	Symbol	Unit	Value			Comment
			MIN	TYP	MAX	
Ambient operating temperature	T _A	°C	- 40		+ 85	
Ambient storage temperature	T _S	°C	- 40		+ 85	
Mass	m	g		60		
Internal magnetic core	—	—	Silicon steel			

SPECIFICATIONS

Ta=+25°C, RL=10kΩ, Vcc=±15V

Parameters	Symbol	Unit	Value			Comment
			MIN	TYP	MAX	
Primary nominal current * 1	L37S050D15 *	I _{PN}	A		50	
	L37S100D15 *				100	
	L37S200D15 *				200	
	L37S300D15 *				300	
	L37S400D15 *				400	
	L37S500D15 *				500	
	L37S600D15 *				600	
Primary current, measuring range * 2	L37S050D15 *	I _{PM}	A	- 150		150
	L37S100D15 *			- 300		300
	L37S200D15 *			- 600		600
	L37S300D15 *			- 900		900
	L37S400D15 *			- 1000		1000
	L37S500D15 *			- 1000		1000
	L37S600D15 *			- 1000		1000
Supply voltage	V _{CC}	V	± 12 (± 5%)	± 15 (± 5%)		
Consumption current	I _{CC}	mA		15	20	at I _p = 0A, I _{CC} = 15 + V _{out} / R _L
Rated output voltage	V _O	V	3.960	4.000	4.040	at I _{PN}
Offset voltage * 3	L37S050D15 *	V _{of}	V	- 0.030	0.000	+ 0.030
	L37S100D15 *			- 0.020	0.000	+ 0.020
	L37S200D15 *			- 0.020	0.000	+ 0.020
	L37S300D15 *			- 0.020	0.000	+ 0.020
	L37S400D15 *			- 0.020	0.000	+ 0.020
	L37S500D15 *			- 0.020	0.000	+ 0.020
	L37S600D15 *			- 0.020	0.000	+ 0.020
Hysteresis error	V _{OH}	mV			± 20	at 0A → I _{PN} → 0A
Temperature coefficient of V _O	TcV _O	%/°C			± 0.1	Without TcV _{of}
Temperature coefficient of V _{of}	L37S050D15 *	TcV _{of}	mV/°C			± 2
	L37S100D15 *					± 1
	L37S200D15 *					± 1
	L37S300D15 *					± 1
	L37S400D15 *					± 1
	L37S500D15 *					± 1
	L37S600D15 *					± 1
Linearity error	ε _L	%	- 1		+ 1	at I _p = 0A ~ I _{PN}
Response time (at 90% of I _{PN}) * 4	t _r	μs			3	di/dt = I _{PN} or 100A/μs. Whichever is smaller.
Frequency bandwidth (-3dB) * 5	BW	kHz		150		at low current

* 1 Products with a primary nominal current of 800A are also available. Please contact us for details.

* 2 If the product of 300A or less operate at V_{CC} = ± 12V power supplies, measuring range reduced to 2.5 x I_{PN}.

* 3 Offset voltage value is after removal of core hysteresis.

* 4 Measurement condition : Primary conductor cross sectional area is as same as through hole, and penetration with 1 turn in through hole.

* 5 High fundamental frequency primary current and/or harmonic current may result in excessive heating in magnetic core (Silicon steel).

STANDARDS



EN62477-1:2012, EN62477-1:2012/A1:2017 and EN62477-1:2012/A11:2014
 Rated voltage 300V, CAT III, PD2, Reinforced isolation, non uniform field

UL508 (file No. E243511)
 Rated voltage 600V, PD2
 ※ Please refer to the another sheet about conditions of UL Recognition.

CONNECTION

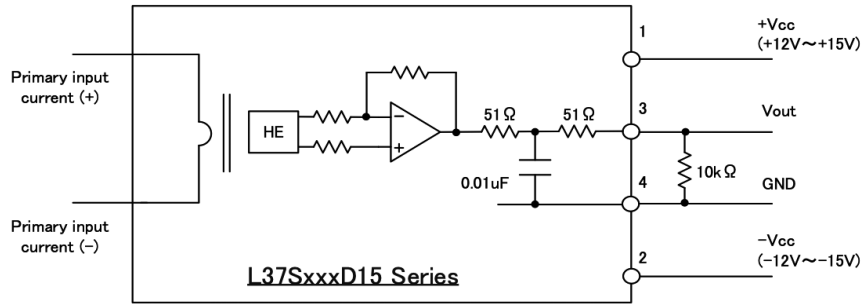

DIMENSIONS (mm)

L37SxxxD15J

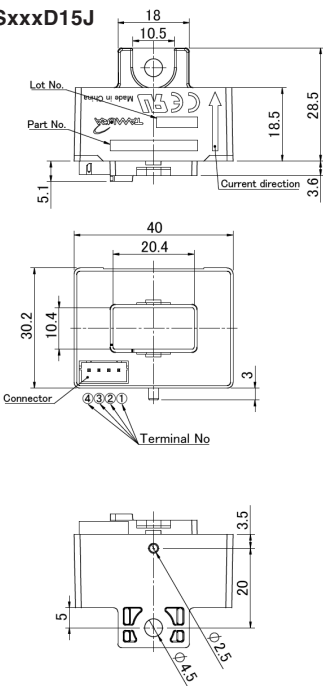

L37SxxxD15M

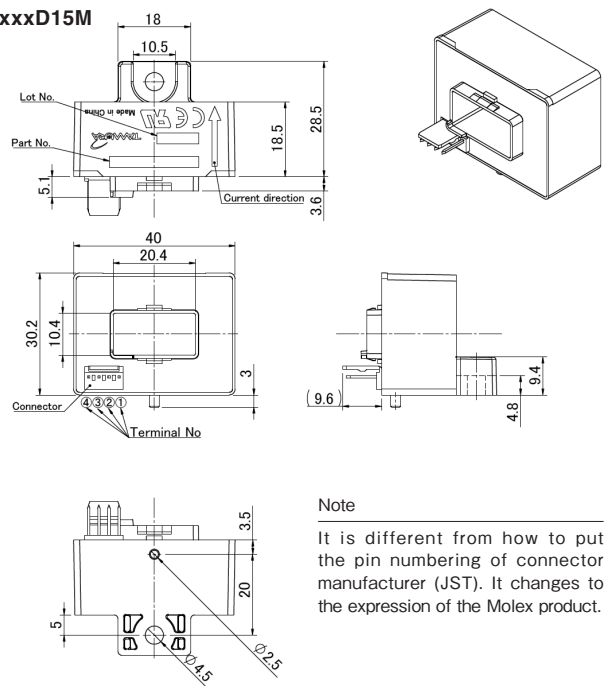

Terminal number

- 1 +Vcc (+15V)
- 2 -Vcc (-15V)
- 3 Vout
- 4 GND

Note

It is different from how to put the pin numbering of connector manufacturer (JST). It changes to the expression of the Molex product.

- Recommended fastening screw type : M4 with flat washer and spring washer
- Recommended fastening torque : < 1.5 N · m

Note

Unless otherwise specified tolerances shall be ± 0.5mm.

Order number and Connector number (terminal plating)

For the L37SxxxD15 series, there are some types with different secondary side connectors. It is determined by the characters that follow the series name. Please do not omit the model number when ordering.

Types		Connector			
		Manufacturer	Part Number	Old Part Number	Plating of terminal
L37SxxxD15M	Standard	Molex	22-04-1041	5045-04A	Sn
L37SxxxD15M-A	Build to Order	Molex	22-11-1041	5045-04AG	Au
L37SxxxD15J	Standard	JST	B4B-XH-A-G	-	Au

- * Rated current (3 figures)
- * As for the L37SxxxD15M series of a gold-plated connector, ' -A' attaches to the end of the product name.
- * The pin number of L37SxxxD15J are different from those of the connector manufacturer (JST). It is matched to the Molex type.

Magnetic Proportion System / Through Type

L03S SERIES

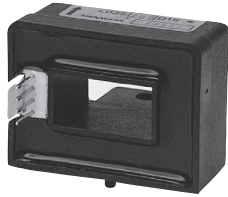

TAMURA recommends L37S series as a succession model.

SPECIFICATIONS

Ta=25°C, RL=10kΩ, Vcc=±15V

Types		Types						
		L03S050D15	L03S100D15	L03S200D15	L03S300D15	L03S400D15	L03S500D15	L03S600D15
Primary nominal current	If	50AT	100AT	200AT	300AT	400AT	500AT	600AT
Saturation current	If max	≥± 150AT	≥± 300AT	≥± 600AT	≥± 700AT	≥± 700AT	≥± 700AT	≥± 700AT
Output voltage	Vo	4V ± 0.040V (at If)						
Offset voltage*1	Vof	≤± 0.040V (at If=0A)	≤± 0.030V (at If=0A)					
Output linearity (without offset)	εL	≤± 1% (at If)						
Power supply voltage	Vcc	± 15V ± 5%						
Consumption current	Icc	± 12mA (typ) , ≤± 20mA						
di/dt Response time*2	tr	≤ 10μs						
Thermal drift of gain	TcVo	≤± 0.1% / °C (without Tc Vof)						
Thermal drift of offset	TcVof	≤± 2mV / °C	≤± 1mV / °C					
Hysteresis error	VoH	≤ 20mV (at If = 0A → If → 0A)						
Insulation voltage	Vd	AC2500V for 1 minute (Sensing current 0.5mA) inside of through hole ⇔ terminal						
Insulation resistance	RiS	≥ 500MΩ (at DC500V) , inside of through hole ⇔ terminal						
Ambient Operating temperature	TA	- 20°C ~ + 80°C						
Ambient storage temperature	TS	- 40°C ~ + 90°C						

* 1 Offset voltage value is after removal of core hysteresis. * 2 The smaller one on either at di/dt = 100A/us or at di/dt = If/us.

DIMENSIONS (mm)

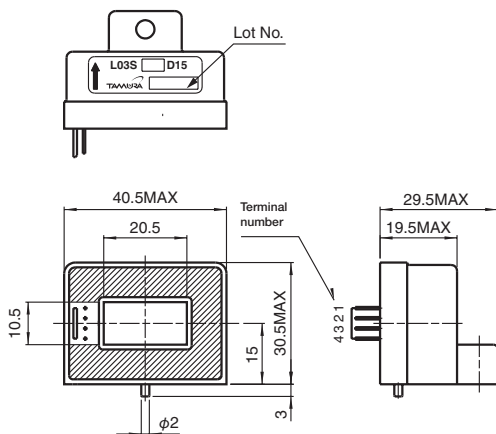

Types		Connector			
		Manufacturer	Part Number	Old Part Number	Plating of terminal
L03SxxxD15	Standard	Molex	22-04-1041	5045-04A	Sn
L03SxxxD15-A	Build to Order		22-11-1041	5045-04AG	Gold

As for the product of a gold-plated connector, 'A' attaches to the end of the product name.

Recommended PCB holes

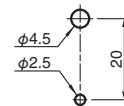

- Terminal number
- 1 + Vcc (+ 15V)
 - 2 - Vcc (- 15V)
 - 3 Vout
 - 4 GND
- Weight:
- 50g
- Note
- 1. Unless otherwise specified, tolerances shall be 0.5mm

Magnetic Proportion System / Through Type

L03S D15W SERIES



TAMURA recommends L37S series as a succession model.

Ta=25°C, RL=10kΩ, Vcc=±15V

SPECIFICATIONS

Spec	Types	Types								
		L03S050D15W	L03S100D15W	L03S200D15W	L03S300D15W	L03S400D15W	L03S500D15W	L03S600D15W	L03S700D15W	L03S800D15W
Primary nominal current	If	50AT	100AT	200AT	300AT	400AT	500AT	600AT	700AT	800AT
Saturation current *1	If max	≥± 150AT	≥± 300AT	≥± 600AT	≥± 900AT	≥± 1000AT				
Output voltage	Vo	4V ± 0.040V (at If)								
Offset voltage *2	Vof	≤± 0.040V (at If=0A)	≤± 0.030V (at If = 0A)							
Output linearity (without offset)	εL	≤± 1% (at If)								
Power supply voltage	Vcc	± 12V (± 5%) ~ ± 15V (± 5%)								
Consumption current	Icc	≤± 20mA								
di/dt Response time *3	tr	≤ 5us (at 90% of If - 90% of Vo) , ≤ 10us (at 10% of If - 90% of Vo)								
Thermal drift of gain	TcVo	≤ 0.1% / °C (Without Tc Vof)								
Thermal drift of offset	TcVof	≤± 2mV / °C	≤± 1mV / °C							
Hysteresis error	VOH	≤ 20mV (at If = 0A → If → 0A)								
Insulation voltage	Vd	AC2500V for 1 minute (Sensing current 0.5mA) inside of through hole ⇔ terminal								
Insulation resistance	RiS	≥ 500MΩ (at DC500V) , inside of through hole ⇔ terminal								
Ambient Operating temperature	TA	- 20°C ~ + 80°C								
Ambient storage temperature	TS	- 40°C ~ + 85°C								

* 1 If the product of 300A or less operate at Vcc = ± 12V power supplies, measuring range reduced to 2.5 x If. * 2 Offset voltage value is after removal of core hysteresis. * 3 The smaller one on either at di/dt = 100A/us or at di/dt = If/us.

DIMENSIONS (mm)

L03S***D15WM

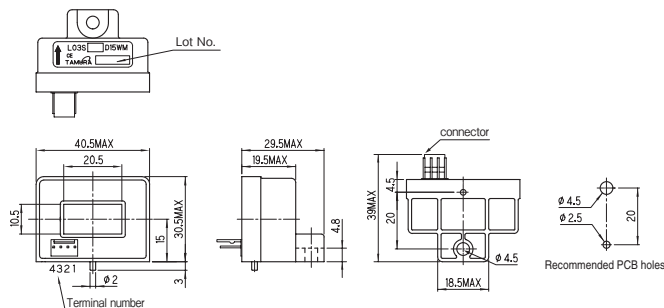

L03S***D15WJ

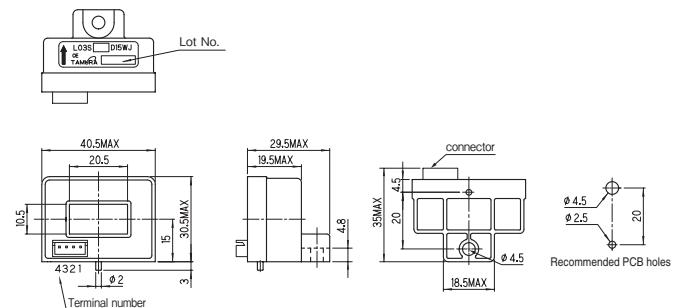

Types	Manufacturer	Connector			
		Part Number	Old Part Number	Plating of terminal	
L03SxxxD15WJ	Standard	JST	B4B-XH-A-G	-	Gold
L03SxxxD15WM	Standard	Molex	22-04-1041	5045-04A	Sn
L03SxxxD15WM-A	Build to Order		22-11-1041	5045-04AG	Gold

Terminal number
 1 + Vcc (+ 15V)
 2 - Vcc (- 15V)
 3 Vout
 4 GND
 Note

Weight
 50g

As for L03SxxxD15WM of a gold-plated connector, '-A' attaches to the end of the product name.

1. Unless otherwise specified, tolerances shall be ± 0.5mm

Magnetic Proportion System / Through Type

L31S S05FS SERIES

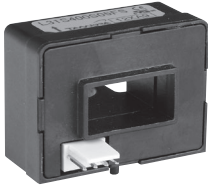

SPECIFICATIONS

Ta=25°C, RL=10kΩ, Vcc=+5.0V

Spec	Types	Symbol	Types						
			L31S050S05FS	L31S100S05FS	L31S200S05FS	L31S300S05FS	L31S400S05FS	L31S500S05FS	L31S600S05FS
Primary nominal current	If		50A	100A	200A	300A	400A	500A	600A
Saturation current	If max		≧ ± 150A	≧ ± 300A	≧ ± 600A	≧ ± 900A	≧ ± 900A	≧ ± 900A	≧ ± 900A
Reference Voltage	V ref		+ 2.495V ± 0.020V *1 (at Rref ≥ 1M Ω . Ouput impedance : typ 200 Ω)						
Rated output voltage	Vo		Vof + 0.625V ± 0.015V (at If)						
Offset voltage	Vof		Vref ± 0.025V (at If=0A) *2						
Output linearity (0A ~ If)	εL		± 0.5% (at 0A, 1/2If, If)						
Power supply voltage	Vcc		+ 5V ± 5%						
Consumption current	Icc		≦ 20mA						
di/dt Response time	tr		≦ 5μs (at di/dt=100A/μs)						
Reference Temperature Characteristic	TcVref		≦ ± 0.012%/°C						
Thermal drift of gain	TcVO		≦ ± 1.5mV/°C (Without TcVof)						
Thermal drift of offset (at If=0A)	TcVof		≦ ± 1.0mV/°C			≦ ± 0.3mV/°C			
Hysteresis error (at 0A → If → 0A)	Voh		≦ ± 10mV			≦ ± 2.5mV			
Insulation voltage	Vd		AC3300V for 1 minute (Sensing current 0.5mA) Primary ⇔ Secondary						
Insulation resistance	Ris		≧ 500M Ω (at DC500V) Primary ⇔ Secondary						
Ambient Operating temperature	TA		- 40 ~ + 85°C						
Ambient storage temperature	TS		- 40 ~ + 85°C						

* 1 It is possible to change Vof with an external reference voltage (between 1.5V - 2.8V providing its ability to sink or source approximately 5 mA.) . If the external reference voltag is not used, the Vref pin should be left unconnected. * 2 Offset voltage value is after removal of core hysteresis. * Please refer to the another sheet about conditions of UL Recognition. * Anti-Sulfurated (Used resistors : Gold internal Electrodes) * Ferrite core is used.

DIMENSIONS (mm)

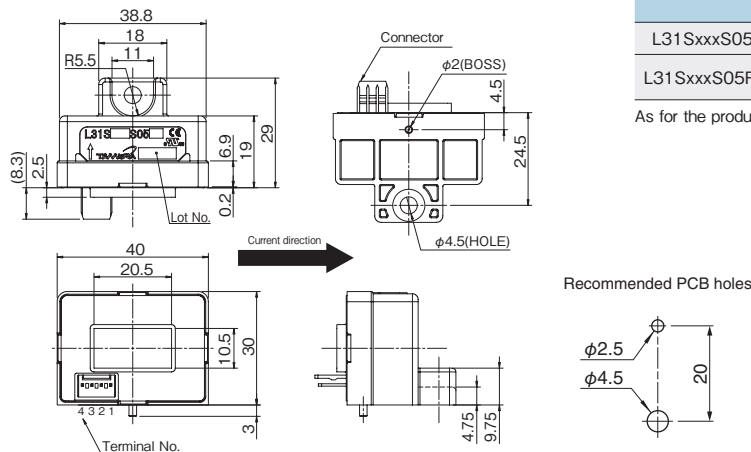

Types	Connector	Connector			
		Manufacturer	Part Number	Old Part Number	Plating of terminal
L31SxxxS05FS	Standard	Molex	22-04-1041	5045-04A	Sn
L31SxxxS05FS-A	Build to Order	Molex	22-11-1041	5045-04AG	Gold

As for the product of a gold-plated connector, '-A' attaches to the end of the product name.

Terminal number	Note
1 Vref (IN/OUT)	1. Unless otherwise specified, tolerances shall be ±0.5mm 2. Unit is [mm]
2 Vout	
3 GND	
4 +Vcc (+5V)	
Weight	
38g	

Magnetic Proportion System / Through Type

L06P S05 SERIES



SPECIFICATIONS

Ta=25°C, RL=10kΩ, Vcc=+5V

Types		L06P300S05	L06P400S05	L06P600S05	L06P800S05
Primary nominal current	If	300AT	400AT	600AT	800AT
Saturation current	If max	≥ If × 1.33			
Rated output voltage	Vo	Vref + 1.5V ± 0.035V (at If) *1			
Offset voltage	Vof	Vref ± 30mV *2			
Output linearity (0A ~ If)	εL	≤ ± 1% (at If)			
Power supply voltage	Vcc	+ 5V ± 0.1V			
Consumption current	Icc	≤ 15mA			
di/dt Response time	tr	≤ 5μs (at di/dt = 100A /μs)			
Thermal drift of gain	TcVo	≤ ± 1.5mV/°C (Without Tc Vof)			
Thermal drift of offset	TcVof	≤ ± 1.0mV/°C (at If = 0A)			
Hysteresis error	VOH	≤ 10mV (at If = 0A → If → 0A)			
Insulation voltage	Vd	AC2500V for 1 minute (Sensing current 0.5mA) Primary ↔ Secondary			
Insulation resistance	RIS	≥ 500M Ω (at DC500V) Primary ↔ Secondary			
Ambient Operating temperature	TA	- 40°C ~ + 85°C			
Ambient storage temperature	TS	- 40°C ~ + 85°C			

* 1 Vref=Vcc/2 * 2 Offset voltage value is after removal of core hysteresis.

DIMENSIONS (mm)

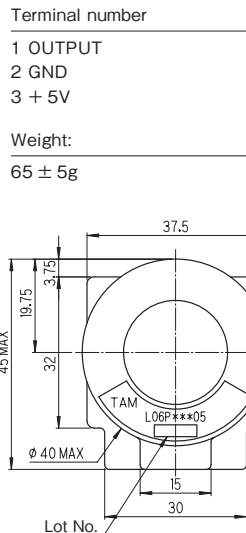
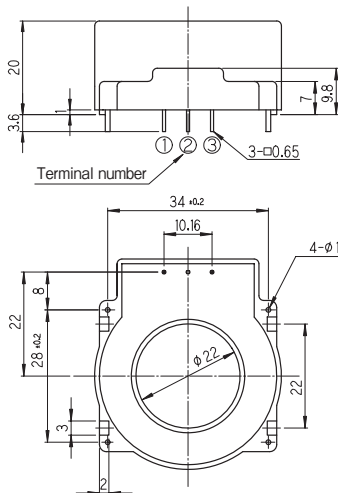

Terminal number
 1 OUTPUT
 2 GND
 3 + 5V

Note
 1. Unless otherwise specified, tolerances shall be ±0.5mm

Weight:
 65 ± 5g

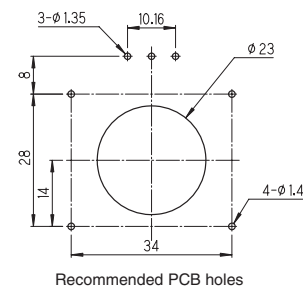

Magnetic Proportion System / Through Type

L05Z SERIES

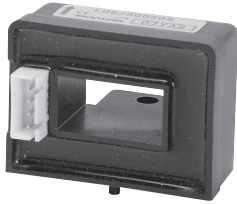

Introduction

Fluxgate system

Open loop

Closed loop

SPECIFICATIONS

Ta=25°C, RL=10kΩ, Vcc=+15V

Types		L05Z800S15
Spec		
Primary nominal current	If	800AT
Saturation current	If max	≥ ± 900AT
Rated output voltage	Vo	11V ± 0.11V (at If)
Offset voltage	Vof	+ 7V ± 50mV (If = 0A)
Output linearity (0A ~ If)	εL	± 1% (at If)
Power supply voltage	Vcc	+ 15V ± 5%
Consumption current	Icc	≤ 20mA
di/dt Response time	tr	≤ 10μs (at di/dt = 100A /μs)
Thermal drift of gain	TcVo	± 0.1% / °C (Without Tc Vof)
Thermal drift of offset	TcVof	± 1.0mV / °C
Hysteresis error	VOH	≤ 20mV (at If = 0A → If → 0A)
Insulation voltage	Vd	AC2500V for 1 minute (Sensing current 0.5mA) inside of through hole ⇔ terminal
Insulation resistance	RIS	≥ 500MΩ (at DC500V) inside of through hole ⇔ terminal
Ambient Operating temperature	TA	- 40°C ~ + 85°C
Ambient storage temperature	TS	- 40°C ~ + 85°C

DIMENSIONS (mm)

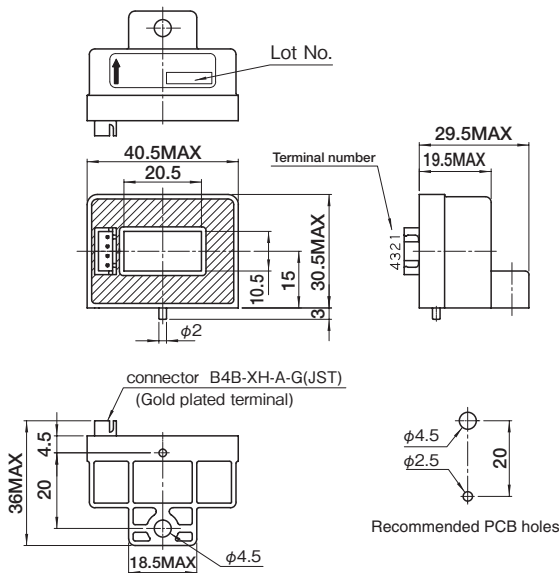

- Terminal number
- 1 + Vcc
 - 2 GND
 - 3 OUT
 - 4 GND

- Note
1. Unless otherwise specified, tolerances shall be ± 0.5mm
 2. Mass is 50 ± 5g.

Magnetic Proportion System

L34S D15 SERIES



SPECIFICATIONS

Ta=25°C, RL=10kΩ, Vcc=±15V

Spec	Types	Symbol	L34S200D15	L34S300D15	L34S400D15	L34S500D15	L34S600D15	L34S800D15	L34S1T0D15	L34S1T2D15	L34S1T5D15
Primary nominal current		If	200A	300A	400A	500A	600A	800A	1000A	1200A	1500A
Saturation current * 1		If max	± 600A	± 900A	± 1200A	± 1500A	± 1800A	± 2400A	± 2500A	± 2500A	± 2500A
Rated Output Voltage		Vo	4V ± 0.040V (at If)								
Offset voltage		Vof	≤ ± 0.020V (at If = 0A) * 2								
Output linearity (without offset)		ε _L	≤ ± 0.5% (at 0A, 1/2If, If)								
Power supply voltage		Vcc	± 12V (± 5%) ~ ± 15V (± 5%)								
Consumption current		Icc	16mA (TYP) ≤ 25mA								
di/dt (@90% of If) Response time		tr	≤ 5μs (di/dt = 100A / μs) * 3								
Thermal drift of gain		T _C Vo	≤ ± 0.05%/°C (Without T _C Vof)								
Thermal drift of offset		T _C Vof	≤ ± 1.0mV/°C (at If=0A)								
Hysteresis error		V _{OH}	≤ ± 10mV (at 0A → If → 0A)								
Insulation voltage		Vd	AC3000V, for 1minute (Sensing current 0.5mA) , inside of through hole ⇔ terminal								
Insulation resistance		R _{IS}	≥ 500M.Ω (at DC500V) inside of through hole ⇔ terminal								
Ambient Operating temperature		T _A	- 30°C ~ + 80°C								
Ambient storage temperature		T _S	- 40°C ~ + 85°C								

* 1 If the product of 800A or less operate at Vcc = ± 12V power supplies, measuring range reduced to 2.5 x If. * 2 Offset voltage value is after removal of core hysteresis. * 3 Measurement condition : Primary conductor cross sectional area is as same as through hole, and penetration with 1turn in through hole. * Please refer to the another sheet about conditions of UL Recognition.

DIMENSIONS (mm)

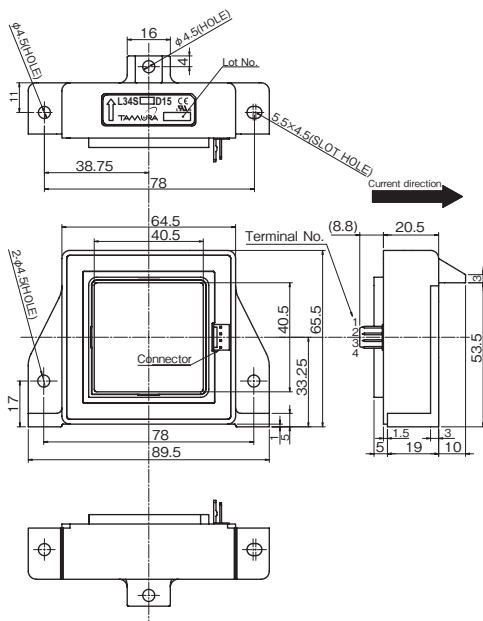

Types		Connector			
		Manufacturer	Part Number	Old Part Number	Plating of terminal
L34SxxxD15	Standard	Molex	22-04-1041	5045-04A	Sn
L34SxxxD15-A	Build to Order		22-11-1041	5045-04AG	Gold

As for the product of a gold-plated connector, '-A' attaches to the end of the product name.

Terminal number	Weight	Note
1 +Vcc (+15V)	165g	1. Unless otherwise specified, tolerances shall be ±0.5mm
2 -Vcc (-15V)		
3 Vout		
4 GND		

Magnetic Proportion System / Through Type, Ta=105°C Operating

L34S D15T SERIES



ABSOLUTE MAXIMUM RATINGS

Parameters	Symbol	Unit	Value	Comment
Supply voltage	Vcc	V	± 18V	
Primary conductor temperature	—	°C	105	
Minimum load resistance	RL	—	2 kΩ	Recommend RL = 10kΩ

ISOLATION CHARACTERISTICS

Parameters	Symbol	Unit	Value	Comment
Insulation voltage	Vd	—	AC3000V, for 1minute (Sensing current 0.5mA)	Primary ⇔ Secondary
Impulse withstand voltage	Vw	kV	6.0	Primary ⇔ Secondary Input waveform : • Front time 1.2μs • Time to half value 50μs • single
Insulation resistance	Ris	—	≧ 500MΩ (at DC500V)	Primary ⇔ Secondary
Clearance distance	dCl	—	6.6mm (MIN)	Primary ⇔ Secondary
Creepage distance	dCp	—	6.6mm (MIN)	Primary ⇔ Secondary
Case material	—	—	UL94 V-0	
Comparative Tracking Index : (CTI)	CTI	V	200 (group IIIa)	

ENVIRONMENTAL AND MECHANICAL CHARACTERISTICS

Parameters	Symbol	Unit	Value			Comment
			MIN	TYP	MAX	
Ambient operating temperature * 1	TA	°C	- 40		+ 105	
Ambient storage temperature	TS	°C	- 40		+ 105	
Mass	m	g		165		
Internal magnetic core	—	—	Silicon steel			

* 1 Temperature of the connector should not exceed 105°C because the absolute maximum temperature of the connector is +105°C.

SPECIFICATIONS

Ta=+25°C, R_L=10kΩ, V_{cc}=±15V

Parameters	Symbol	Unit	Value			Comment
			MIN	TYP	MAX	
Primary nominal current	L34S200D15T	I _{PN}	A		200	
	L34S300D15T				300	
	L34S400D15T				400	
	L34S500D15T				500	
	L34S600D15T				600	
	L34S800D15T				800	
	L34S1T0D15T				1000	
	L34S1T2D15T				1200	
	L34S1T5D15T				1500	
Primary current, measuring range * 1,2	L34S200D15T	I _{PM}	A	- 600		600
	L34S300D15T			- 900		900
	L34S400D15T			- 1200		1200
	L34S500D15T			- 1500		1500
	L34S600D15T			- 1800		1800
	L34S800D15T			- 2400		2400
	L34S1T0D15T			- 2500		2500
	L34S1T2D15T			- 2500		2500
	L34S1T5D15T			- 2500		2500
Supply Voltage	V _{cc}	V	± 12 (± 5%)	± 15 (± 5%)		
Consumption current	I _{cc}	mA		16	25	at I _p = 0A, I _{cc} = 16 + V _{out} / R _L
Rated output voltage	V _o	V	3.960	4.000	4.040	at I _{PN}
Offset voltage * 3	V _{of}	V	- 0.020	0.000	+ 0.020	at I _p = 0A
Hysteresis error	V _{OH}	mV	- 10		± 10	at 0A → I _{PN} → 0A
Temperature coefficient of V _o	TcV _o	%/°C	- 0.05		+ 0.05	Without TcV _{of}
Temperature coefficient of V _{of}	TcV _{ref}	mV/°C	- 1.0		± 1.0	at I _p = 0A
Linearity error (0A ~ I _{PN})	ε _L	%	- 0.5		+ 0.5	at 0A, 1/2I _{PN} , I _{PN}
Response time (@90% of I _p) * 4	t _r	μs			5	di/dt=100A/μs
Frequency bandwidth (- 3dB) * 5	BW	kHz	25			at very low current

* 1 If the product of 800A or less operate at V_{cc} = ± 12V power supplies, measuring range reduced to 2.5 x I_{PN}.
 * 2 The value of measured current which indicates an output with a greater than ± 5% deviation from the theoretical output value.
 * 3 Offset voltage value is after removal of core hysteresis.
 * 4 Measurement condition : Primary conductor cross sectional area is as same as through hole, and penetration with 1 turn in through hole.
 * 5 High fundamental frequency primary current and/or harmonic current may result in excessive heating in magnetic core (Silicon steel).

STANDARDS

 EN62477-1:2012, EN62477-1:2012/A1:2017 and EN62477-1:2012/A11:2014
 Rated voltage 300V, CAT III, PD2, Reinforced isolation, non uniform field

 UL508, CSA C22.2 No.14-18 (CSA FILE No. 218328)
 Rated voltage 600Vrms, PD2

※ Please refer to the another sheet about conditions of UL Recognition.

Introduction

Fluxgate system

Open loop

Closed loop

CONNECTION

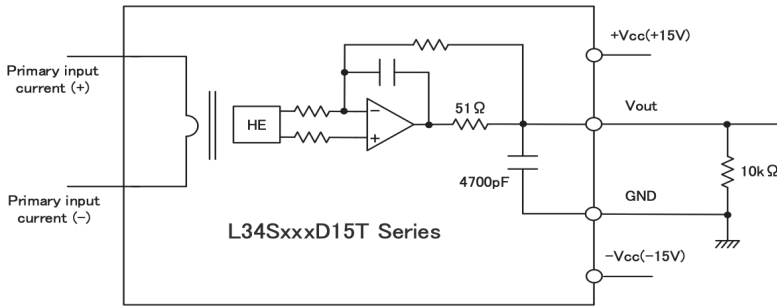

DIMENSIONS (mm)

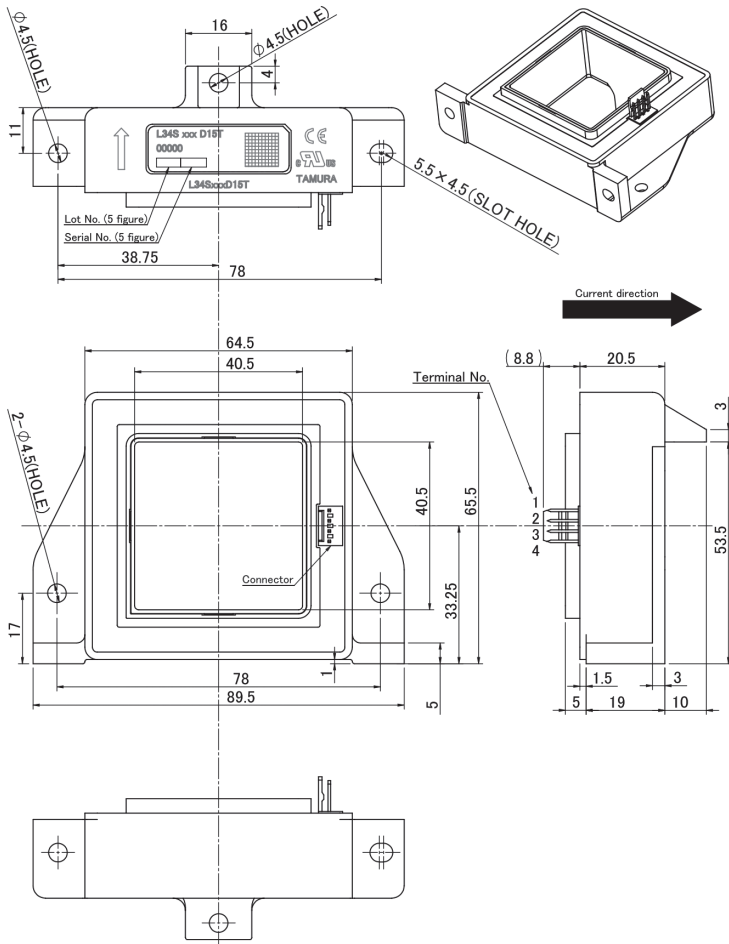

- Terminal number
- 1 +Vcc (+15V)
 - 2 -Vcc (-15V)
 - 3 Vout
 - 4 GND
- Unit mm
- Note
- Unless otherwise specified tolerances shall be ±0.5mm.

Order number and Connector number (terminal plating)

Types		Connector			
		Manufacturer	Part Number	Old Part Number	Plating of terminal
L34SxxxD15T	Standard	Molex	22-04-1041	5045-04A	Sn
L34SxxxD15T-A	Build to Order		22-11-1041	5045-04AG	Au

*As for the L34SxxxD15T series of a gold-plated connector, '-A' attaches to the end of the product name.

Magnetic Proportion System / Through Type

L40S D15 SERIES



- [STANDARDS]**
- UL508
 - CSA C22.2 No.14-18
 - EN 62477-1
 - EN 50178



ABSOLUTE MAXIMUM RATINGS

Parameters	Symbol	Unit	Value	Comment
Supply voltage	Vcc	V	± 18V	
Primary conductor temperature	—	°C	105	

ISOLATION CHARACTERISTICS

Parameters	Symbol	Unit	Value	Comment
Insulation voltage	Vd	—	AC5400V, for 1minute (Sensing current 0.5mA)	Primary ↔ Secondary
			L40SxxxD15C***	
Impulse withstand voltage	Vw	kV	9.6	Primary ↔ Secondary Input waveform : • Front time 1.2μs • Time to half value 50μs • single
			L40SxxxD15C***	
Insulation resistance	R _{IS}	—	≥ 1000M Ω (at DC500V)	Primary ↔ Secondary
Clearance distance	d _{Cl}	—	11.0mm (MIN)	Primary ↔ Secondary
			L40SxxxD15C***	
Creepage distance	d _{cp}	—	12.7mm (MIN)	Primary ↔ Secondary
			L40SxxxD15C***	
Case material	—	—	UL94 V-0	
Comparative Tracking Index : (CTI)	Case	CTI	V	600 (group I)
	Filler			

ENVIRONMENTAL AND MECHANICAL CHARACTERISTICS

Parameters	Symbol	Unit	Value			Comment
			MIN	TYP	MAX	
Ambient operating temperature * 1	T _A	°C	- 40		+ 105	
Ambient storage temperature	T _S	°C	- 40		+ 105	
Mass	m	g		280		

* 1 Temperature of the connector should not exceed +105°C because the absolute maximum temperature of the connector is +105°C.

SPECIFICATIONS

Ta=+25°C, RL=10kΩ, Vcc=±15V

Parameters	Symbol	Unit	Value			Comment
			MIN	TYP	MAX	
Primary nominal current	L40S200D15****	I _{PN}	A		200	
	L40S400D15****				400	
	L40S500D15****				500	
	L40S600D15****				600	
	L40S800D15****				800	
	L40S1T0D15****				1000	
	L40S1T2D15****				1200	
	L40S1T5D15****				1500	
Primary current, measuring range * 1, 2	L40S200D15****	I _{PM}	A	-600		600
	L40S400D15****			-1200		1200
	L40S500D15****			-1500		1500
	L40S600D15****			-1800		1800
	L40S800D15****			-2400		2400
	L40S1T0D15****			-2800		2800
	L40S1T2D15****			-2800		2800
	L40S1T5D15****			-2800		2800
Supply Voltage	Vcc	V	± 12 (± 5%)	± 15 (± 5%)		
Consumption current	Icc	mA		17	25	at I _p = 0A, Icc = 17 + Vout / RL
Rated output voltage	Vo	V	3.960	4.000	4.040	at I _{PN}
Offset voltage * 3	Vof	V	-0.020	0.000	+0.020	at I _p = 0A
Hysteresis error	V _{OH}	mV	-10		10	at 0A → I _{PN} → 0A
Temperature coefficient of Vo	TcVo	%/°C	-0.05		0.05	Without TcVof
Temperature coefficient of Vof	TcVof	mV/°C	-1.0		1.0	at I _p = 0A
Linearity error (0A ~ I _{PN})	ε _L	%	-1		+1	
Response time (@90% of I _{PN}) * 4	tr	μs			5	di/dt=100A/μs
Frequency bandwidth (-3dB) * 5	BW	kHz	25			at very low current

*1 If the product of 800A or less operate at Vcc = ± 12V power supplies, measuring range reduced to 2.5 x I_{PN}.
 *2 The value of measured current which indicates an output with a greater than ± 5% deviation from the theoretical output value.
 *3 Offset voltage value is after removal of core hysteresis.
 *4 Measurement condition : Primary conductor cross sectional area is as same as through hole, and penetration with 1 turn in through hole.
 *5 High fundamental frequency primary current and/or harmonic current may result in excessive heating in magnetic core (Silicon steel).

STANDARDS



EN62477-1:2012, EN62477-1:2012/A1:2017 and EN62477-1:2012/A11:2014

Rated voltage L40SxxxD15*** 600V, CAT III, PD2, Reinforced isolation, non uniform field
 L40SxxxD15C*** 1000V, CAT III, PD2, Reinforced isolation, non uniform field

EN50178:1997

Rated voltage L40SxxxD15C*** 1500V, CAT III, PD2, Reinforced isolation, non uniform field



UL508, CSA C22.2 No.14-18 (CSA FILE No. 218328)

Rated voltage L40SxxxD15*** 600V, PD2
 L40SxxxD15C*** 1500V, PD2

CONNECTION

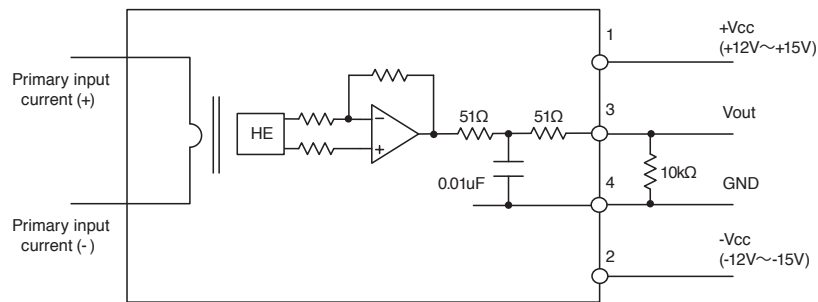

DIMENSIONS (mm)

L40SxxxD15M/M-A

L40SxxxD15J

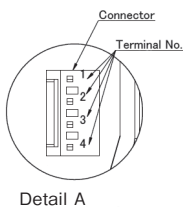
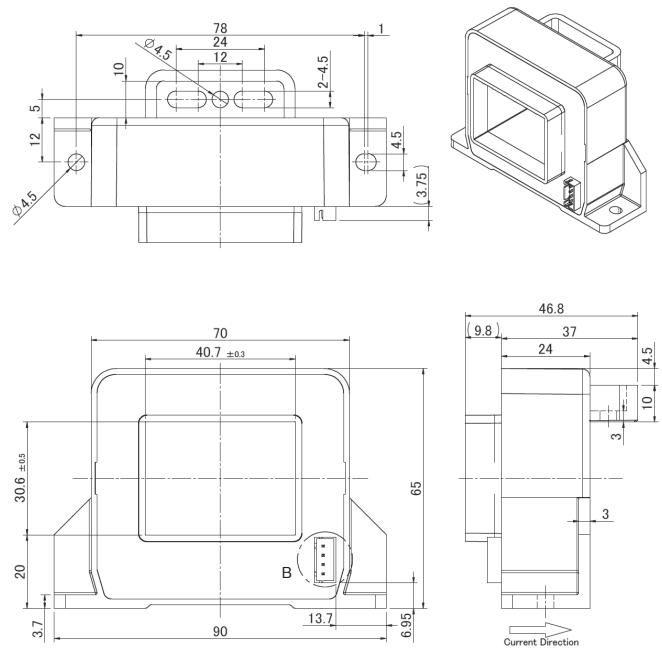
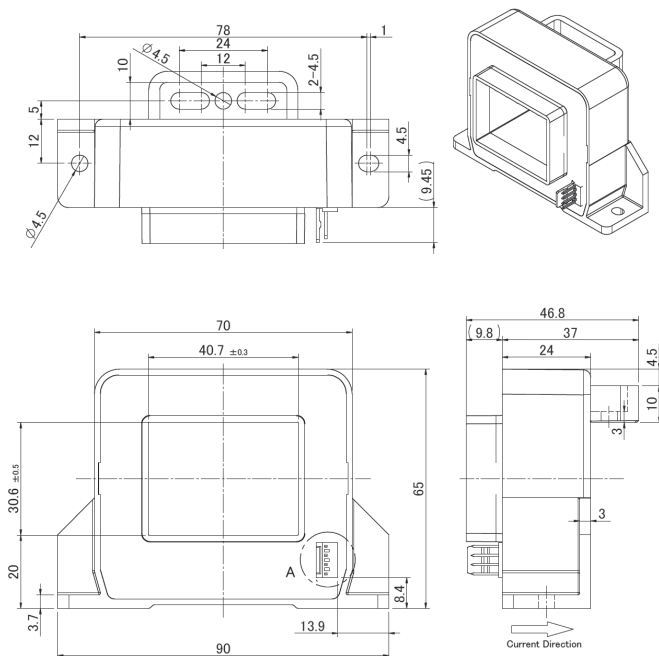

Terminal No.
 ① +Vcc (+15V)
 ② -Vcc (-15V)
 ③ Vout
 ④ GND
 ※ Tolerance: ± 1
 Unit: mm

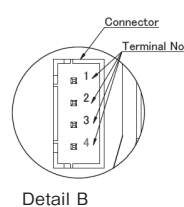

Terminal No.
 ① +Vcc (+15V)
 ② -Vcc (-15V)
 ③ Vout
 ④ GND
 ※ Tolerance: ± 1
 Unit: mm

DIMENSIONS (mm)

L40SxxxD15CM/CM-A

L40SxxxD15CJ

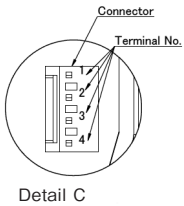
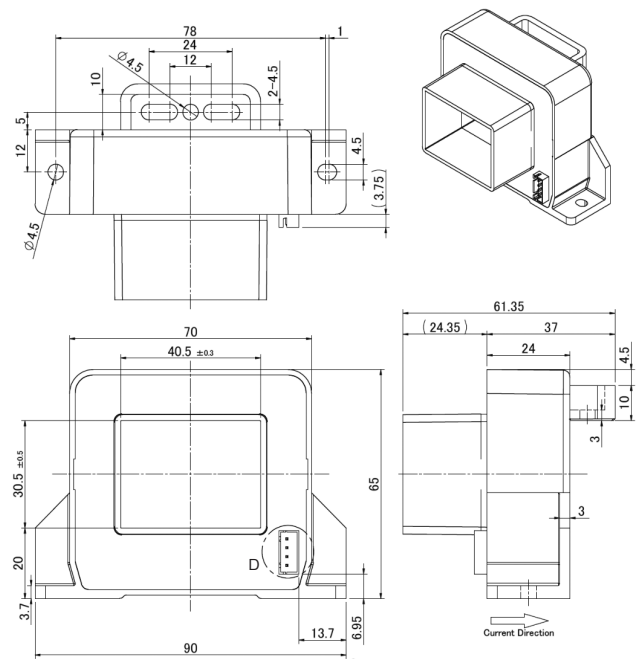
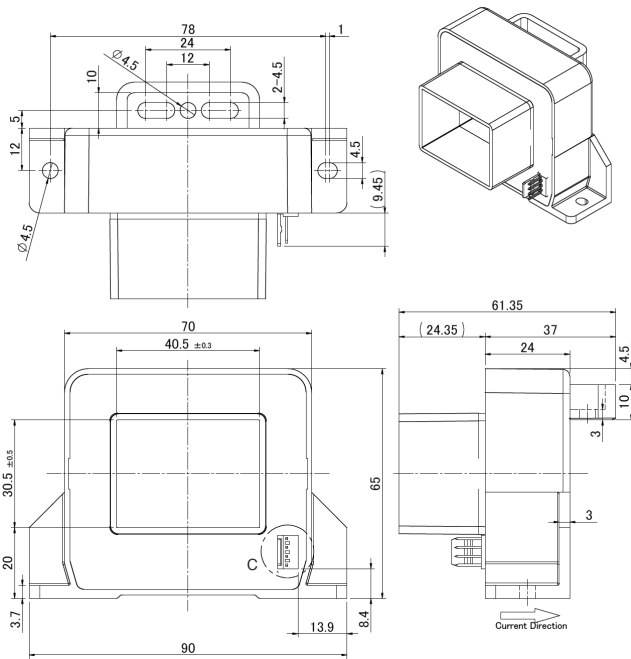

- Terminal No.
- ① +Vcc (+15V)
 - ② -Vcc (-15V)
 - ③ Vout
 - ④ GND
- ※ Tolerance: ± 1
Unit: mm

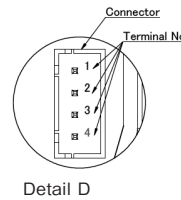

- Terminal No.
- ① +Vcc (+15V)
 - ② -Vcc (-15V)
 - ③ Vout
 - ④ GND
- ※ Tolerance: ± 1
Unit: mm

MARKING

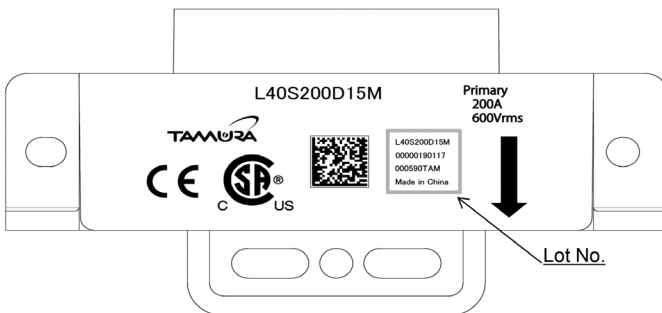

Lot No. 例 Example of Lot No.
L40SxxxD15**** ← Types
00000190117 ← Revision code(5 figure), Date code(6 figure)
000590TAM ← Serial No.(4 figure), Factory code(2 figure)
Made in China ← Country of production

Order number and Safety application / Connector number (terminal plating)

Types		Safety application		Connector						
		UL508-600V EN	UL508-1500V EN	Manufacturer	Part Number	Old Part Number	Plating of terminal			
L40SxxxD15J	Standard	○	○	JST	B4B-XH-A-G	-	Au			
L40SxxxD15CJ										
L40SxxxD15M	Standard	○	○	Molex	22-04-1041	5045-04A	Sn			
L40SxxxD15CM										
L40SxxxD15M-A	Build to Order	○	○					22-11-1041	5045-04AG	Au
L40SxxxD15CM-A										

* As for the L40SxxxD15M series of a gold-plated connector, 'A' attaches to the end of the product name.

Magnetic Proportion System / Through Type

L51S D15 SERIES



[STANDARDS]
 •UL508
 •CSA C22.2 No.14-18
 •EN 62477-1
 •EN 50178



ABSOLUTE MAXIMUM RATINGS

Parameters	Symbol	Unit	Value	Comment
Supply voltage	Vcc	V	± 18V	
Primary conductor temperature	—	°C	120	

ISOLATION CHARACTERISTICS

Parameters	Symbol	Unit	Value	Comment	
Insulation voltage	L51SxxxD15*** L51SxxxD15L***	Vd	—	AC5400V, for 1minute (Sensing current 0.5mA)	Primary ↔ Secondary
	L51SxxxD15C***				
	Impulse withstand voltage	L51SxxxD15*** L51SxxxD15L***	Vw	kV	
L51SxxxD15C***		16.5			
Insulation resistance		R _{IS}	—	≥ 1000M Ω (at DC500V)	Primary ↔ Secondary
Clearance distance	L51SxxxD15*** L51SxxxD15L***	d _{Cl}	—	11.0mm (MIN)	Primary ↔ Secondary
	L51SxxxD15C***			20.0mm (MIN)	Primary ↔ Secondary
Creepage distance	L51SxxxD15*** L51SxxxD15L***	d _{cp}	—	12.7mm (MIN)	Primary ↔ Secondary
	L51SxxxD15C***			30.5mm (MIN)	Primary ↔ Secondary
Case material	—	—	—	UL94 V-0	
Filler material	—	—	—	UL94 V-0	
Comparative Tracking Index : (CTI)	Case	CTI	V	600 (group I)	
	Filler			600 (group I)	

ENVIRONMENTAL AND MECHANICAL CHARACTERISTICS

Parameters	Symbol	Unit	Value			Comment
			MIN	TYP	MAX	
Ambient operating temperature * 1	T _A	°C	- 40		+ 105	
Ambient storage temperature	T _S	°C	- 40		+ 105	
Mass	m	g		400		
Internal magnetic core	—	—	Silicon steel			

* 1 Temperature of the connector should not exceed 105°C because the absolute maximum temperature of the connector is +105°C .

SPECIFICATIONS

Ta=+25°C, RL=10kΩ, Vcc=±15V

Parameters	Symbol	Unit	Value			Comment
			MIN	TYP	MAX	
Primary nominal current	L51S500D15****	I _{PN}	A		500	
	L51S600D15****				600	
	L51S850D15****				850	
	L51S1T0D15****				1000	
	L51S1T2D15****				1200	
	L51S1T5D15****				1500	
	L51S2T0D15****				2000	
	L51S2T5D15****				2500	
Primary current, measuring range * 1, 2	L51S500D15****	I _{PM}	A	-1500		1500
	L51S600D15****			-1800		1800
	L51S850D15****			-2550		2550
	L51S1T0D15****			-3000		3000
	L51S1T2D15****			-3600		3600
	L51S1T5D15****			-4500		4500
	L51S2T0D15****			-5500		5500
	L51S2T5D15****			-5500		5500
Supply Voltage	Vcc	V	± 12(± 5%)	± 15(± 5%)		
Consumption current	Icc	mA		20	30	at I _p = 0A, Icc = 20 + Vout / RL
Rated output voltage	Vo	V	3.960	4.000	4.040	at I _{PN}
Offset voltage * 3	Vof	V	-0.020	0.000	+0.020	at I _p = 0A
Hysteresis error	V _{OH}	mV			± 30	at 0A → I _{PN} → 0A
Temperature coefficient of Vo	TcVo	%/°C			± 0.1	Without TcVof
Temperature coefficient of Vof	TcVof	mV/°C	-1		+1	at I _p = 0A
Linearity error (0A ~ I _{PN})	ε _L	%	-1		+1	
Output load resistance	RL	k Ω		10		
Response time (@90% of I _{PN}) * 4	tr	μs			5	di/dt=100A/μs
Frequency bandwidth (-3dB) * 5	BW	kHz	25			at very low current

*1 If the product of 1500A or less operate at Vcc = ± 12V power supplies, measuring range is reduced to 2.5 x I_{PN}.
 *2 The value of measured current which indicates an output with a greater than ± 5% deviation from theoretical output value.
 *3 Offset voltage value is after removal of core hysteresis.
 *4 Measurement condition : Primary conductor cross sectional area is as same as through hole, and penetration with 1 turn in through hole.
 *5 High fundamental frequency primary current and/or harmonic current may result in excessive heating in magnetic core(Silicon steel).

STANDARDS



EN62477-1:2012, EN62477-1:2012/A1:2017 and EN62477-1:2012/A11:2014
 Rated voltage L51SxxxD15***, L51SxxxD15L*** 600V, CAT III, PD2, Reinforced isolation, non uniform field
 L51SxxxD15C*** 1000V, CAT III, PD2, Reinforced isolation, non uniform field

EN50178:1997
 Rated voltage L51SxxxD15C*** 1500V, CAT III, PD2, Reinforced isolation, non uniform field



UL508, CSA C22.2 No.14-18 (UL FILE No. E243511)
 Rated voltage L51SxxxD15***, L51SxxxD15L*** 600V, PD2
 L51SxxxD15C*** 1500V, PD2

CONNECTION

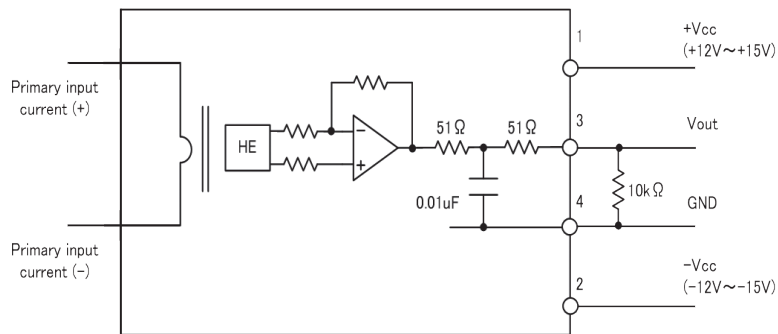

DIMENSIONS (mm)

L51SxxxD15J

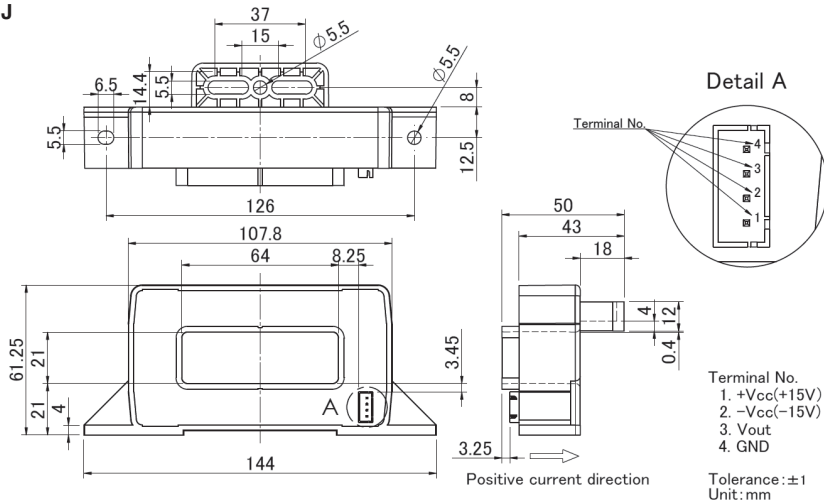

NOTE
 It is different from how to put the pin numbering of connector manufacturer (JST). It changes to the expression of the Molex product.

L51SxxxD15M/M-A

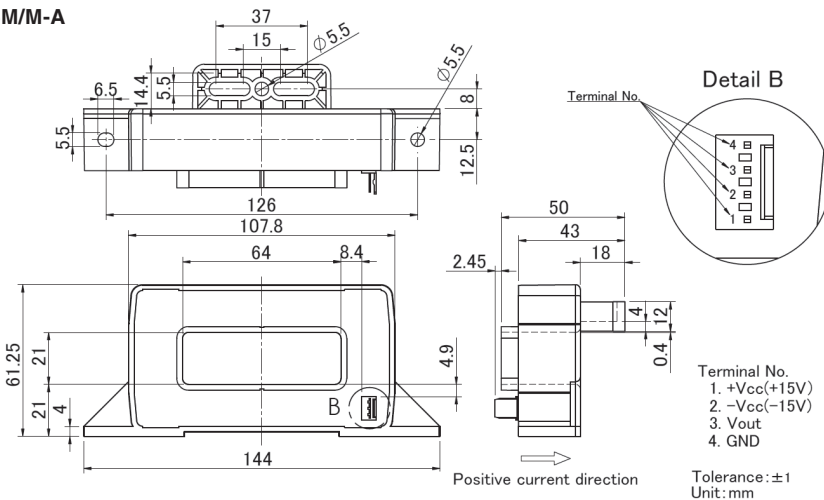

L51SxxxD15CJ

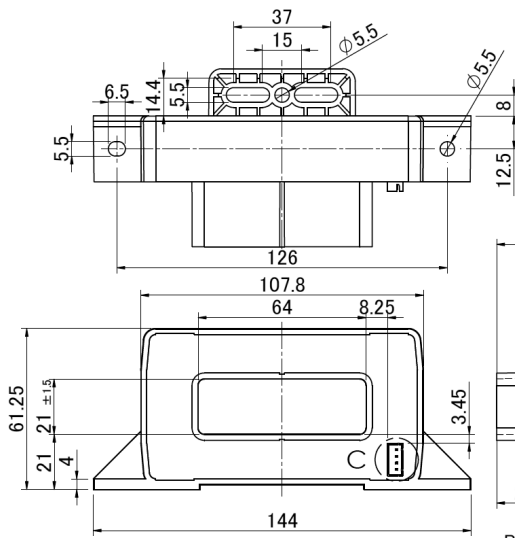

NOTE

It is different from how to put the pin numbering of connector manufacturer (JST). It changes to the expression of the Molex product.

Detail C

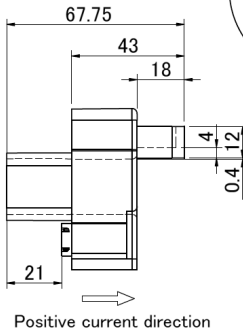
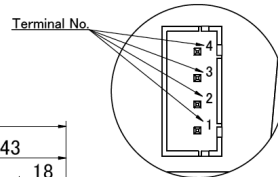

- Terminal No.
 1. +Vcc(+15V)
 2. -Vcc(-15V)
 3. Vout
 4. GND

Tolerance: ±1
 Unit: mm

L51SxxxD15M/CM/M-A/CM-A

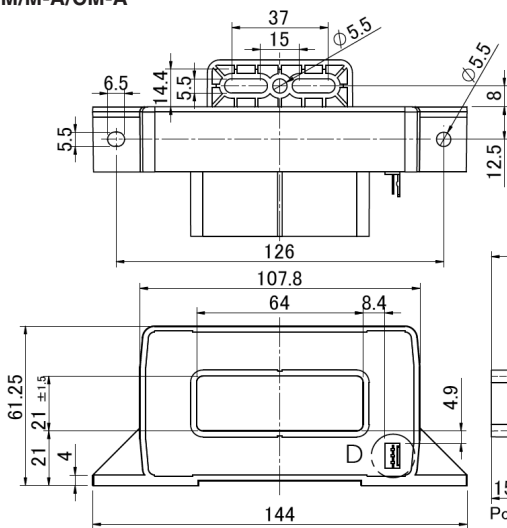

Detail D

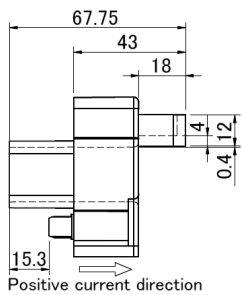
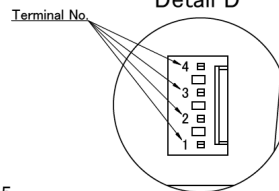

- Terminal No.
 1. +Vcc(+15V)
 2. -Vcc(-15V)
 3. Vout
 4. GND

Tolerance: ±1
 Unit: mm

L51SxxxD15LJ

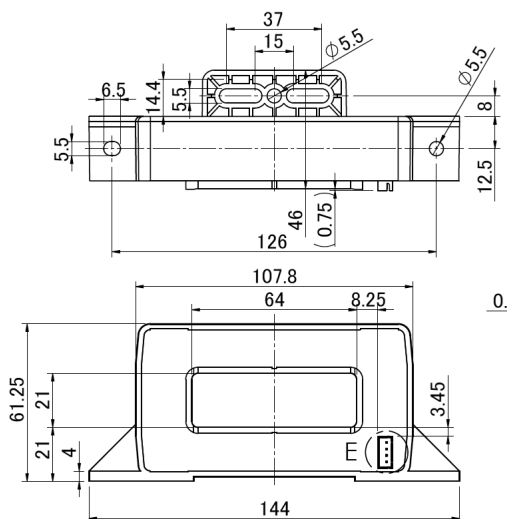

NOTE

It is different from how to put the pin numbering of connector manufacturer (JST). It changes to the expression of the Molex product.

Detail E

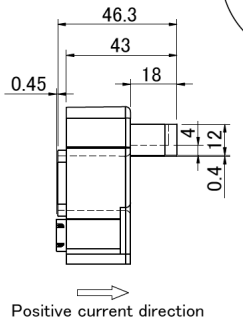
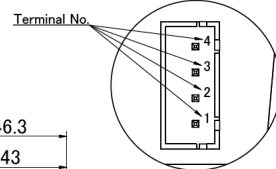

- Terminal No.
 1. +Vcc(+15V)
 2. -Vcc(-15V)
 3. Vout
 4. GND

Tolerance: ±1
 Unit: mm

L51SxxxD15LM/LM-A

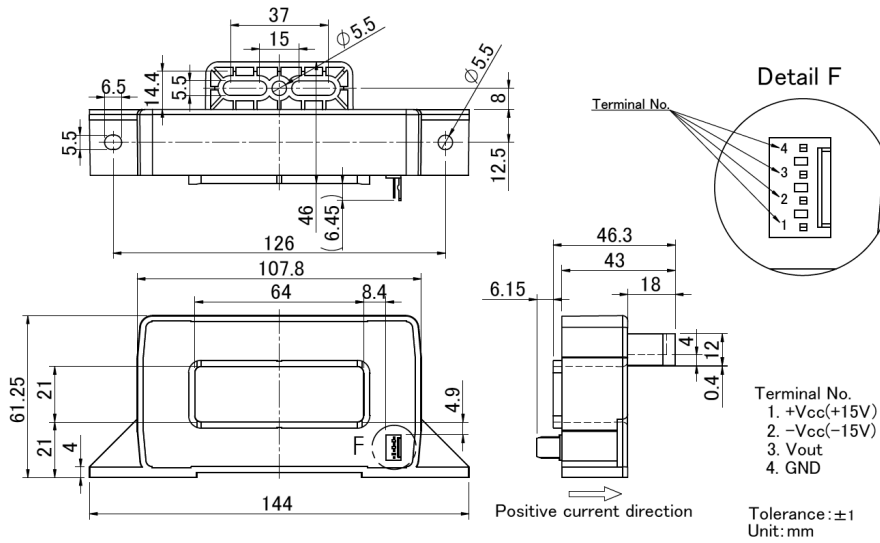

- Recommended fastening screw type : M5 with flat washer and spring washer
- Recommended fastening torque : < 1.5 N · m

MARKING

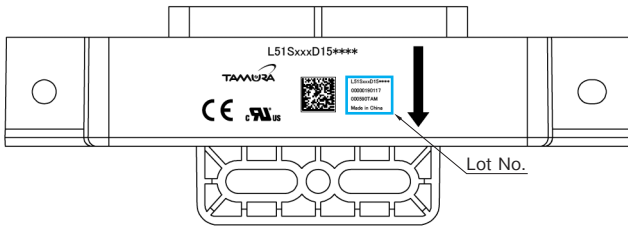

Example of Lot No.

L51SxxxD15****
 (*6) 0190117
 000590TAM
 Made in China

Types
 Revision code(1 figure), Date code(6 figures)
 Serial No.(4 figures), Factory code(2 figures)
 Country of production

*6 Digit number adjustment code

Order number and Safety application / Connector number (terminal plating)

Types	Safety application		Connector			
	UL508-600V EN	UL508-1500V EN	Manufacturer	Part Number	Old Part Number	Plating of terminal
L51SxxxD15J	○		JST	B4B-XH-A-G	—	Au
L51SxxxD15LJ	○					
L51SxxxD15CJ		○				
L51SxxxD15M	○		Molex	22-04-1041	5045-04A	Sn
L51SxxxD15LM	○					
L51SxxxD15CM		○				
L51SxxxD15M-A	○					
L51SxxxD15LM-A	○		22-11-1041		5045-04AG	Au
L51SxxxD15CM-A		○				

* Rated current (3 figures)
 * As for the L51SxxxD15M series of a gold-plated connector, ' -A ' attaches to the end of the product name.
 * The pin number of "B4B-XH-A-G" are different from those of the connector manufacturer (JST). It is matched to the Molex type.

Magnetic Proportion System / Non ratiometric output, Vref-OUT/IN mode, Ta=105°C Operating,

LA17P S05 SERIES



[STANDARDS]
 •UL508
 •CSA C22.2 No.14
 •EN 62477-1

RoHS

ABSOLUTE MAXIMUM RATINGS

Parameters	Symbol	Unit	Value	Comment
Maximum supply voltage (not destructive)	V _{CC}	V	15	
Operational supply voltage (not entering non standard modes)	V _{CC}	V	7.2	
Primary conductor temperature	—	°C	120	
ESD (HBM : Human Body Model)	V _{ESD}	kV	2	C=150 pF, R=330 Ω

ISOLATION CHARACTERISTICS

Parameters	Symbol	Unit	Value	Comment
Insulation voltage	V _d	—	AC4300V, for 1minute(Sensing current 0.5mA)	Primary ⇔ Secondary
Impulse withstand voltage	V _w	kV	8.0	Primary ⇔ Secondary Input waveform : • Front time 1.2μs • Time to half value 50μs • single
Clearance distance	d _{cl}	—	8.0 mm (MIN)	Primary ⇔ Secondary
Creepage distance	d _{cp}	—	8.0 mm (MIN)	Primary ⇔ Secondary
Case material	—	—	UL94 V-0	
Comparative Tracking Index; (CTI)	CTI	V	600 (group I)	

ENVIRONMENTAL AND MECHANICAL CHARACTERISTICS

Parameters	Symbol	Unit	Value			Comment
			MIN	TYP	MAX	
Ambient operating temperature	T _A	°C	- 40		+ 105	
Ambient storage temperature	T _S	°C	- 40		+ 105	
Mass	m	g		6.5		
Internal magnetic core	—	—	Ferrite			

SPECIFICATIONS

T_A = +25°C RL = 10 kΩ CL_{out} = 4.7 nF CL_{ref} = 47 nF, V_{cc} = +5.0 V

Parameters		Symbol	Unit	Value			Comment
				MIN	TYP	MAX	
Primary nominal current	LA17P010S05	I _{PN}	A		10		
	LA17P016S05				16		
	LA17P020S05				20		
	LA17P032S05				32		
	LA17P040S05				40		
	LA17P050S05				50		
Primary current, measuring range	LA17P010S05	I _{PM}	A	- 25		25	V _{cc} > 4.8V Ref OUT mode
	LA17P016S05			- 40		40	
	LA17P020S05			- 50		50	
	LA17P032S05			- 80		80	
	LA17P040S05			- 100		100	
	LA17P050S05			- 125		125	
Number of primary turns		N _p	T	1			
Primary conductor resistance	T _A = 25°C	R _p	m Ω		0.21		
	T _A = 105°C				0.28		
Supply voltage		V _{cc}	V	4.5	5.0	5.5	
Consumption current		I _{cc}	mA		16	23	@ I _p = 0A, I _{cc} = 16+ V _{out} / RL
Internal reference voltage (output)		V _{ref1}	V	2.48	2.50	2.52	Ref OUT mode
External reference input voltage		V _{ref2}	V	0.50		2.65	Ref IN mode
Reference source current		I _{ref}	mA	0.5	0.7	1.0	V _{ref} to GND. See "support docu..." section.
Reference sink current		I _{ref}	mA		5	10	V _{ref} to V _{cc} . See "support docu..." section.
Output voltage range (@ I _{PM})		V _{out} -V _{ref}	V	- 2		2	Ref OUT mode
Internal output resistance of V _{ref}		R _{ref}	Ω	150	200	300	
Internal output resistance of V _{out}		R _{out}	Ω		2	5	
External capacitive load of V _{ref}		C _{L,ref}	nF	0.5		47	
External capacitive load of V _{out}		C _{L,out}	nF			4.7	
Electrical offset voltage (@ I _p =0 A) * 1		V _{oe}	mV	- 5		5	V _{out} - V _{ref} @ V _{ref} = 2.5 V
Temperature drift of V _{ref}		V _{refT}	mV	- 10		10	@T _A = - 40°C~ 105°C
Temperature drift of V _{oe} (@ I _p =0 A)		V _{oeT}	mV	- 10		10	@T _A = - 40°C~ 105°C
Theoretical sensitivity	LA17P010S05	G _{th}	mV/A		80.0		800mV @ I _{PN} V _{out} = V _{ref} + V _{oe} + (G _{th} × I _p)
	LA17P016S05				50.0		
	LA17P020S05				40.0		
	LA17P032S05				25.0		
	LA17P040S05				20.0		
	LA17P050S05				16.0		
Sensitivity error * 2		ε _G	%	- 0.5		0.5	@ I _{PN}
Temperature drift of sensitivity		G _T	%	- 3		3	@T _A = - 40°C~ 105°C

* 1 Electrical offset voltage value is after removal of magnetic offset voltage (core hysteresis).

* 2 It is the adjustment value at the time of shipment from the factory.

SPECIFICATIONS

T_A = +25°C RL = 10 kΩ CL_{out} = 4.7 nF CL_{ref} = 47 nF, V_{cc} = +5.0 V

Parameters	Symbol	Unit	Value			Comment	
			MIN	TYP	MAX		
Linearity error	@0A ~ I _{PN}	ε _L	%	-0.5		0.5	
	@0A ~ I _{PM}			-0.5		0.5	
Magnetic offset current referred to primary	I _{OM}	A	-0.25		0.25	@ I _P = 10 × I _{PN}	
Reaction time (@ 10 % of I _{PN})	t _{ra}	μs			2	@di/dt= I _{PN} / μs	
Response time (@ 90 % of I _{PN})	t _r	μs			2.5	@di/dt= I _{PN} / μs	
Frequency bandwidth	BW	kHz		400		@ - 3dB	
Accuracy * 3	T _A =25°C	X1	% of I _{PN}	-1.0		1.0	@ I _{PN}
	T _A =105°C	X2	% of I _{PN}	-5.3		5.3	

* 3 Accuracy formula is following Accuracy X1 = ε_G + ε_L
Accuracy X2 = X1 + (V_{oeT} / 800 × 100) + G_T

STANDARDS



EN62477-1:2012, EN62477-1:2012/A1:2017 and EN62477-1:2012/A11:2014
Rated voltage 600 V, CAT III, PD2, Reinforced isolation, non uniform field



UL508, CSA C22.2 No.14 (UL FILE No. E243511)
Rated voltage 600 V, PD2

The devices have been evaluated that they are intended to be supplied from an isolated secondary circuit of Limited Voltage/Current circuit or Limiting Impedance circuit defined in United States Standard or Industrial Control Equipment, UL 508.

※ Please refer to the another sheet about conditions of UL Recognition.

CHARACTERISTIC CURVE (TYP)

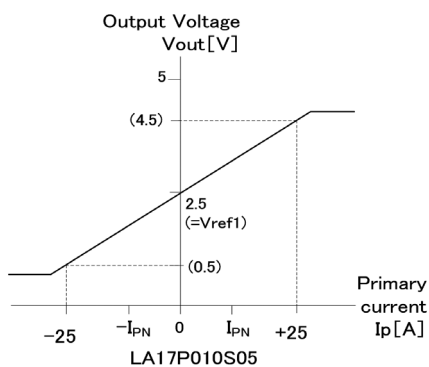

Fig 1 : Linearity curve Internal reference voltage)

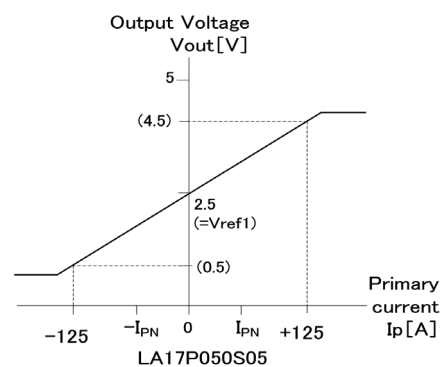

Fig 2 : Linearity curve Internal reference voltage)

SUPPORT DOCUMENTATION

Reference voltage

The Ref pin can be used as Ref OUT mode and/or Ref IN mode.

<Ref OUT mode>

The 2.5 V internal reference is used by the transducer as the reference point for bipolar measurements.

<Ref IN mode>

An external reference voltage is connected to the Ref pin. This voltage is specified in the range 0.5 to 2.65 V, its voltage is used as the offset voltage at the measurement.

The following graphs (Fig3) show the output voltage (@ Ip = 0A) and the reference input / output current due to the external reference voltage value Vref2.

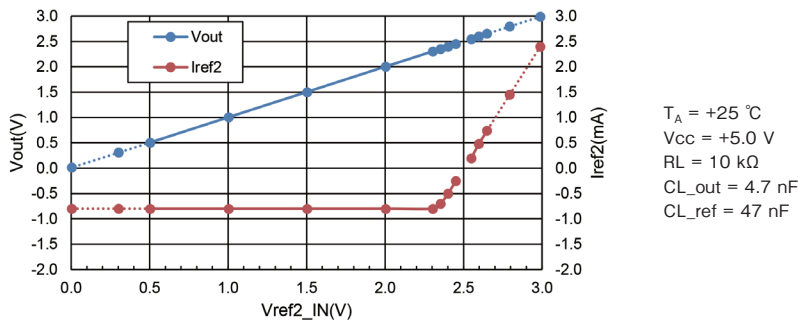
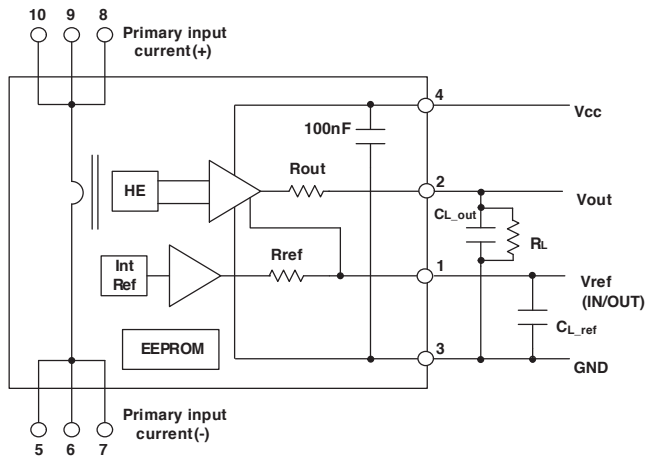

Fig 3 : Vref2 input voltage vs Output voltage and Iref2 (= Vref2 current) (Typical performance)

CONNECTION



Condition (Standard)
 C1 = 100 nF
 CL_ref = 0.5 nF MIN , 4.7 nF MAX
 CL_out = 4.7 nF MAX
 RL = 10kΩ

< Notice >

- Capacitors are recommended for Vout and Vref terminals in order to reduce the noise of the output voltage.
 Vout terminal : 4.7 nF, Vref terminal : 47 nF.

DIMENSIONS (mm)

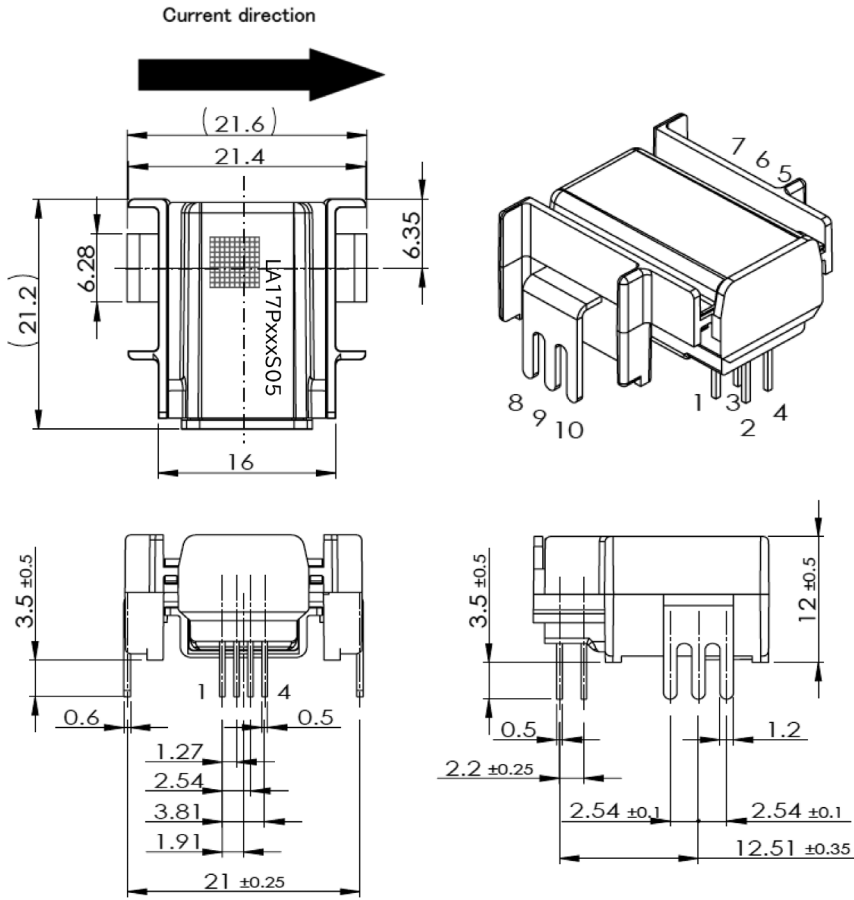

- Terminal No.
- 1 : Vref (IN/OUT)
 - 2 : Vout
 - 3 : GND
 - 4 : Vcc (+5V)
 - 5 : Primary input current(-)
 - 6 : Primary input current(-)
 - 7 : Primary input current(-)
 - 8 : Primary input current(+)
 - 9 : Primary input current(+)
 - 10 : Primary input current(+)

Tolerance : ± 0.2
Unit : mm

RECOMMEND HOLE DIAMETER (unit : mm)

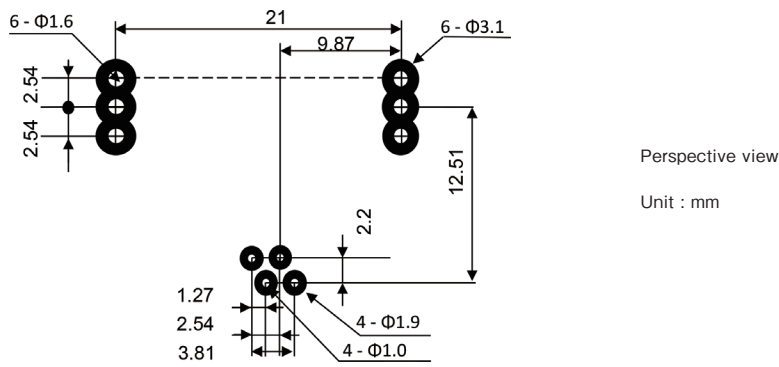

Servo system / Voltage-output type External magnetic field improvement type

S22P M2 SERIES



SPECIFICATIONS

Ta=25°C, RL=10kΩ, Vcc=+5V

Types		S22P006S05M2	S22P015S05M2	S22P025S05M2
Primary nominal current	If	6A	15A	25A
Saturation current	If max	± 18A	± 45A	± 75A
Rated output voltage	Vo	Vof ± 0.625V (at If)		
Output voltage accuracy	XG	0.625V ± 0.010V (at If)		
Offset voltage*1	Vof	2.5V ± 0.050V (at If = 0A)	2.5V ± 0.020V (at If = 0A)	2.5V ± 0.015V (at If = 0A)
Output linearity	εL	≤ ± 0.2% (at If)		
Power supply voltage	Vcc	+ 5V ± 5%		
Consumption current	Icc	Typ. 12.5mA (If=0A) + 37.5mA (If max)		
di/dt Response time (@90% of If)	tr	≤ 1μs (at di / dt = If / μs)		
Thermal drift of gain	TcVo	≤ ± 0.05mV / °C (Without TcVof)		
Thermal drift of offset	TcVof	- 10 ~ 25°C : ± 1.6mV / °C 25 ~ 85°C : ± 0.8mV / °C	- 10 ~ 25°C : ± 0.6mV / °C 25 ~ 85°C : ± 0.3mV / °C	- 10 ~ 25°C : ± 0.4mV / °C 25 ~ 85°C : ± 0.2mV / °C
Hysteresis error	VOH	≤ 0.5mV (at If = 0A → If → 0A)		
Insulation voltage	Vd	AC3000V for 1 minute (Sensing current 0.5mA) Primary ↔ Secondary		
Insulation resistance	RIS	≥ 500M Ω (at DC500V) Primary ↔ Secondary		
Ambient Operating temperature	TA	- 10°C ~ + 85°C		
Ambient storage temperature	TS	- 25°C ~ + 100°C		

* 1 Offset voltage value is after removal of core hysteresis. * Please refer to the another sheet about conditions of UL Recognition.

DIMENSIONS (mm)

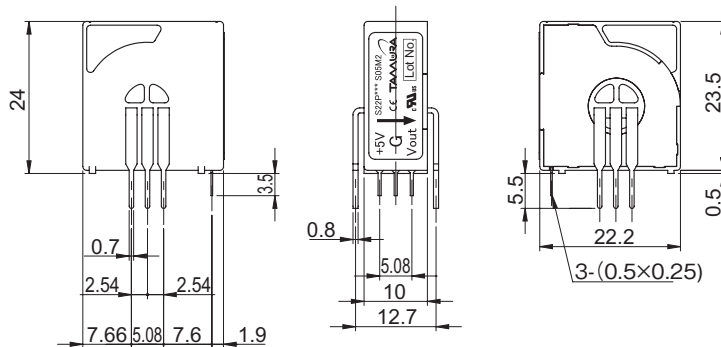

Note
 1. Unless otherwise specified, tolerances shall be ±0.5mm
 2. Unit is [mm]

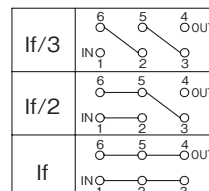
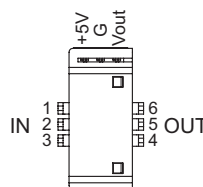

Weight:
8g typ

Servo system / Voltage-output type / Short lead model

S22P P SERIES

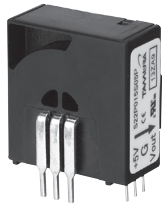

SPECIFICATIONS

Ta=25°C, RL=10kΩ, Vcc=+5V

Types		S22P006S05P	S22P015S05P	S22P025S05P
Primary nominal current	If	6A	15A	25A
Saturation current	If max	± 18A	± 45A	± 75A
Rated output voltage	Vo	Vof ± 0.625V (at If)		
Output voltage accuracy	XG	0.625V ± 0.010V (at If)		
Offset voltage*1	Vof	2.5V ± 0.050V (at If = 0 A)	2.5V ± 0.020V (at If = 0 A)	2.5V ± 0.015V (at If = 0 A)
Output linearity	εL	≤ ± 0.2% (at If)		
Power supply voltage	Vcc	+ 5V ± 5%		
Consumption current	Icc	Typ.12.5mA (If=0A) + 37.5mA (If max)		
di / dt Response time (@90% of If)	tr	≤ 1μs (di/dt = If / μs)		
Thermal drift of gain	TcVo	≤ ± 0.05mV / °C (Without TcVof)		
Thermal drift of offset	TcVof	- 10 ~ 25°C : ± 1.6mV / °C 25 ~ 85°C : ± 0.8mV / °C	- 10 ~ 25°C : ± 0.6mV / °C 25 ~ 85°C : ± 0.3mV / °C	- 10 ~ 25°C : ± 0.4mV / °C 25 ~ 85°C : ± 0.2mV / °C
Hysteresis error	VOH	≤ 0.5mV (at If = 0A → If → 0A)		
Insulation voltage	Vd	AC3000V for 1 minute (Sensing current 0.5mA) Primary ↔ Secondary		
Insulation resistance	RIS	≥ 500M Ω (at DC500V) Primary ↔ Secondary		
Ambient Operating temperature	TA	- 10°C ~ + 85°C		
Ambient storage temperature	TS	- 25°C ~ + 100°C		

* 1 Offset voltage value is after removal of core hysteresis. * Please refer to the another sheet about conditions of UL Recognition.

DIMENSIONS (mm)

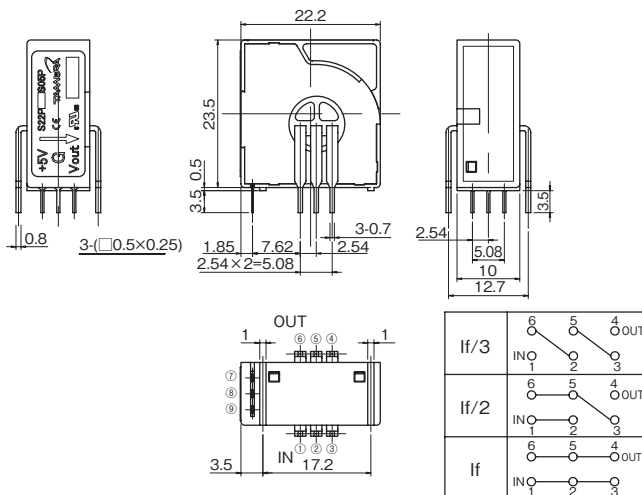

Tolerance : ±0.5
Unit : mm

Servo system Current-output type

S23P M2

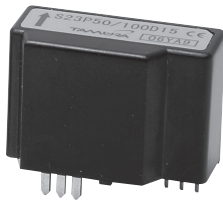

SPECIFICATIONS

Ta=25°C, Vcc=±15V

Types		S23P50/100D15M2			
Spec		50A		100A	
Primary nominal current	If	50A		100A	
Measuring resistance (If= ± ADC, Ta=85°C)	RL	Vcc= ± 12V	0 Ω~ 217 Ω	Vcc= ± 12V	0 Ω~ 57 Ω
		Vcc= ± 15V	0 Ω~ 327 Ω	Vcc= ± 15V	45 Ω~ 114 Ω
Output current	Io	25mA (Turn ratio 1 : 2000)		50mA (Turn ratio 1 : 2000)	
Output current accuracy	XG	Io ± 0.25% (without Iof)			
Offset current	Iof	≤ ± 0.15mA (at If=0A) *1			
Maximum current Vcc= ± 15V (Operating time: ≤ 10sec)	If max	± 110A (at RL ≤ 71 Ω)		± 160A (at RL ≤ 25 Ω)	
Output linearity	εL	≤ ± 0.15% (at If)			
Power supply voltage	Vcc	± 12V ± 5% ~ ± 15V ± 5% (Rated output current is restricted by Vcc)			
Consumption current	Icc	≤ ± 16mA (without Io)			
di/dt Response time (@90% of If)	tr	≤ 0.5μs (at di/dt = 100A/μs)			
Thermal drift of gain	Tclo	≤ ± 0.01%/°C (Without Tclof)			
Thermal drift of offset	Tclof	≤ ± 0.5mA (- 25°C~+ 85°C)			
Hysteresis error	Ioh	0.01mA_TYP (Non-output saturated state. At If=0A → If → 0A) ≤ 0.15mA (Output saturation state. At If=0A → 3 × If → 0A, RL =100)			
Insulation voltage	Vd	AC5000V for 1 minute (Sensing current 0.5mA) Primary ⇄ Secondary			
Insulation resistance	RIS	≥ 500M Ω (at DC500V) Primary ⇄ Secondary			
Ambient Operating temperature	TA	- 40°C~+ 85°C			
Ambient storage temperature	TS	- 40°C~+ 90°C			
Secondary coil resistance	RS	at Ta=70°C 115 Ω at Ta=85°C 121 Ω			

* 1 Offset current value is after removal of core hysteresis. * Please refer to the another sheet about conditions of UL Recognition.

DIMENSIONS (mm)

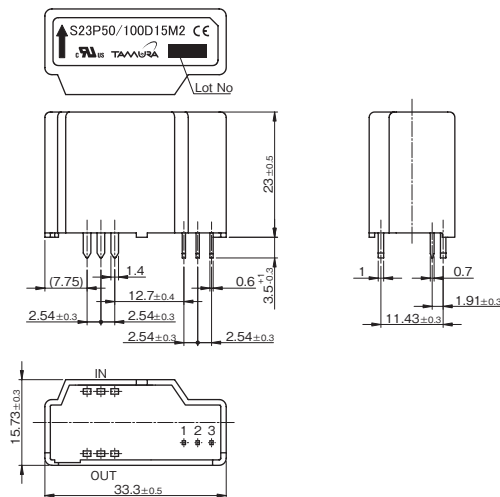

- Terminal number
- 1 - Vcc
 - 2 + Vcc
 - 3 OUT
- Weight:
- 26g typ
- Note
- 1. Unless otherwise specified, tolerances shall be ±0.5mm
 - 2. Unit is [mm]

Servo system Current-output type

S23P M1

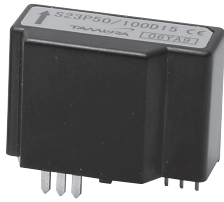

SPECIFICATIONS

Ta=25°C, Vcc=±15V

Types		S23P50/100D15M1			
Spec		50A		100A	
Primary nominal current	If	50A		100A	
Measuring resistance If= ± ADC at Ta=85°C	RL	Vcc= ± 12V	20 Ω~ 145 Ω	Vcc= ± 12V	20 Ω~ 57 Ω
		Vcc= ± 15V	48 Ω~ 205 Ω	Vcc= ± 15V	48 Ω~ 85 Ω
Rated output current	Io	50mA (Turn ratio 1 : 1000)		100mA (Turn ratio 1 : 1000)	
Output current accuracy	XG	Io ± 0.25% (without Iof)			
Offset current	Iof	≤ ± 0.3mA (at If=0A) *1			
Maximum current Vcc= ± 12V (Operating time: ≤ 3sec)	If max	± 226A (at RL=7.5 Ω)			
Output linearity	εL	≤ ± 0.15% (at If)			
Power supply voltage	Vcc	± 12V ± 5% ~ ± 15V ± 5% (Rated output current is restricted by Vcc)			
Consumption current	Icc	≤ ± 16mA (without Io)			
di/dt Response time (@90% of If)	tr	≤ 0.5μs (at di / dt = 100A/μs)			
Thermal drift of gain	Tclo	≤ ± 0.01%/°C (Without Tclof)			
Thermal drift of offset	Tclof	± 0.5mA type, ≤ ± 0.8mA max (-25°C~+ 85°C)			
Hysteresis error	Ioh	0.02mA_TYP (Non-output saturated state. At If=0A → If → 0A) ≤ 0.3mA (Output saturation state. At If=0A → 3 × If → 0A, RL =100)			
Insulation voltage	Vd	AC5000V for 1 minute (Sensing current 0.5mA) Primary ↔ Secondary			
Insulation resistance	RIS	≥ 500M.Ω (at DC500V) Primary ↔ Secondary			
Ambient Operating temperature	TA	- 40°C~+ 85°C			
Ambient storage temperature	TS	- 40°C~+ 90°C			
Secondary coil resistance	RS	at Ta=70°C 33.Ω at Ta=85°C 35.Ω			

* 1 Offset current value is after removal of core hysteresis. * Please refer to the another sheet about conditions of UL Recognition.

DIMENSIONS (mm)

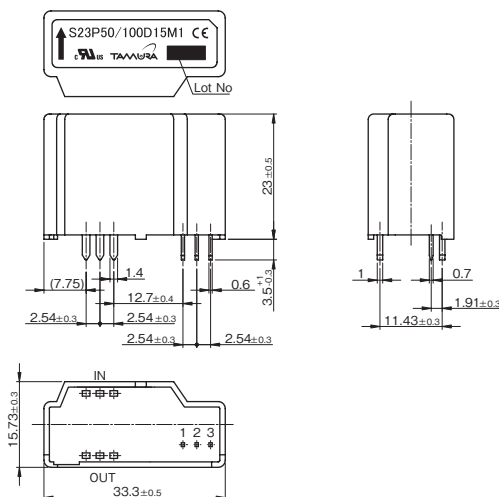

Terminal number

- 1 - Vcc
- 2 + Vcc
- 3 OUT

Weight:

26g typ

Note

1. Unless otherwise specified, tolerances shall be ±0.5mm
2. Unit is [mm]

Servo system Current-output type

S23P

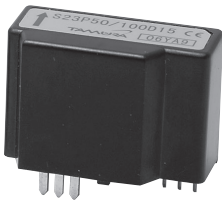

TAMURA recommends S23P50/100D15M2 as a succession model.

SPECIFICATIONS

Ta=25°C, Vcc=±15V

Types		S23P50/100D15			
Spec		50A		100A	
Primary nominal current	If				
Measuring resistance If= ± ADC at Ta=85°C	RL	Vcc= ± 12V	0 Ω~ 217 Ω	Vcc= ± 12V	0 Ω~ 57 Ω
		Vcc= ± 15V	0 Ω~ 327 Ω	Vcc= ± 15V	45 Ω~ 114 Ω
Rated output current	Io	25mA (Turn ratio 1 : 2000)		50mA (Turn ratio 1 : 2000)	
Output current accuracy	XG	Io ± 0.25% (without Iof)			
Offset current	Iof	± 0.15mA (at If=0A) *1			
Maximum current Vcc= ± 15V (Operating time: ≤ 10sec)	If max	± 110A (at RL ≤ 71 Ω)		± 160A (at RL ≤ 25 Ω)	
Output linearity	εL	± 0.15% (at If)			
Power supply voltage	Vcc	± 12V ± 5% ~ ± 15V ± 5% (Rated output current is restricted by Vcc)			
Consumption current	Icc	≤ ± 16mA (without Io)			
di/dt Response time (@90% of If)	tr	≤ 0.5μs (di / dt = 100A/μs)			
Thermal drift of gain	Tclo	± 0.01%/°C (Without Tclof)			
Thermal drift of offset	Tclof	± 0.5mA max (-25°C~+85°C)			
Hysteresis error	Ioh	≤ 0.3mA (at If=0A → If → 0A)			
Insulation voltage	Vd	AC5000V for 1 minute (Sensing current 0.5mA) Primary ↔ Secondary			
Insulation resistance	RIS	≥ 500M Ω (at DC500V) Primary ↔ Secondary			
Ambient Operating temperature	TA	-40°C~+85°C			
Ambient storage temperature	TS	-40°C~+90°C			
Secondary coil resistance	RS	at Ta=70°C 115 Ω		at Ta=85°C 121 Ω	

* 1 Offset current value is after removal of core hysteresis. * Please refer to the another sheet about conditions of UL Recognition.

DIMENSIONS (mm)

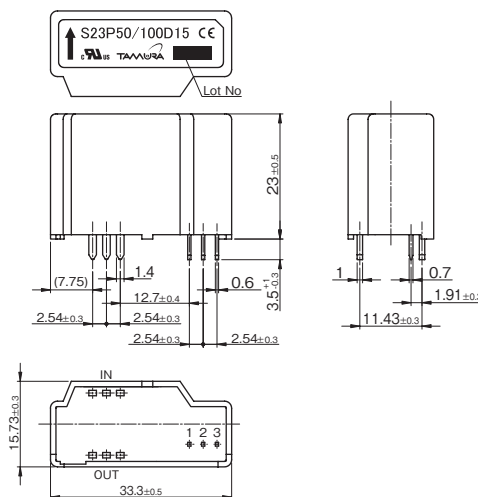

- Terminal number
- 1 - Vcc
 - 2 + Vcc
 - 3 OUT
- Weight:
- 26g typ
- Note
1. Unless otherwise specified, tolerances shall be ±0.5mm
 2. Unit is [mm]

Servo system / Current-output type

S21S SERIES



SPECIFICATIONS

Ta=25°C, Vcc=±15V

Spec	Types	S21S180D15JN
Primary nominal current	If	180A
Measuring Resistance (at 80°C)	R _L	0 ~ 68 Ω (at Vcc= ± 12V) 0 ~ 100 Ω (at Vcc= ± 15V)
Rated output Current	I _o	45mA (Turn Ratio: 1:4000)
Output Current Accuracy	X _G	I _o ± 1% (at I _f without I _{of})
Offset Current	I _{of}	≤ ± 0.2mA (at I _f =0A) *1
Maximum Current	I _f max	± 540A (TA=25°C, at 5 ≤ R _M ≤ 30 Ω; at TA=80°C, 5 ≤ R _M ≤ 20 Ω)
Output Linearity	ε _L	≤ ± 0.3% (at I _f)
Power supply voltage	Vcc	± 12V ± 5% ~ ± 15V ± 5% (Rated output current is restricted by Vcc)
Consumption Current	I _{cc}	≤ ± 16mA (without I _o)
di/dt Response Time (@90% of I _f)	t _r	≤ 1μs (at di/dt=100A/μs)
Thermal drift of gain	TC _{lo}	≤ ± 0.02%/°C (without TC _{lof})
Thermal drift of offset	TC _{lof}	≤ ± 0.01mA/°C
Hysteresis error	I _{oH}	≤ 0.2mA (at I _f = 0A → I _f → 0A)
Insulation voltage	V _d	AC2500V for 1 minute (Sensing current 0.5mA) inside of through hole ⇔ terminal
Insulation resistance	R _{is}	≥ 500M Ω (at DC500V) inside of through hole ⇔ terminal
Ambient Operating temperature	T _A	- 30°C ~ + 80°C
Ambient storage temperature	T _S	- 40°C ~ + 85°C
Secondary coil resistance	R _s	48 Ω (at T _A =25°C), 60 Ω (at T _A =80°C)

* 1 Offset current value is after removal of core hysteresis. * Please refer to the another sheet about conditions of UL Recognition.

DIMENSIONS (mm)

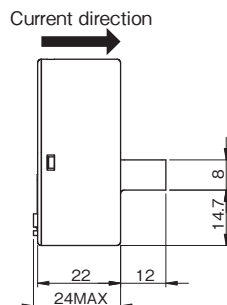
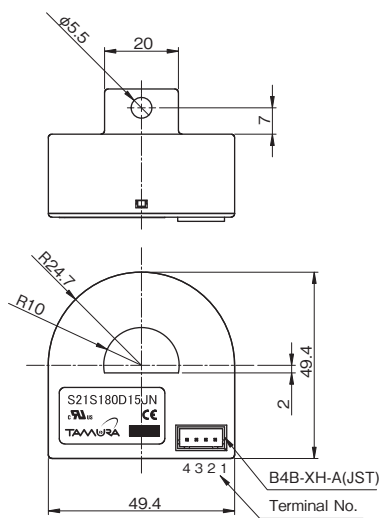

Terminal number
 1 + Vcc
 2 - Vcc
 3 OUT
 4 N.C.

Weight:
 60g typ

- Note
1. Unless otherwise specified, tolerances shall be ±0.5mm
 2. Unit is [mm]
 3. Recommended fastening screw type : M5 with flat washer and spring washer
 4. Recommended fastening torque : < 1.5 N·m

Servo system Current-output type

S27S SERIES

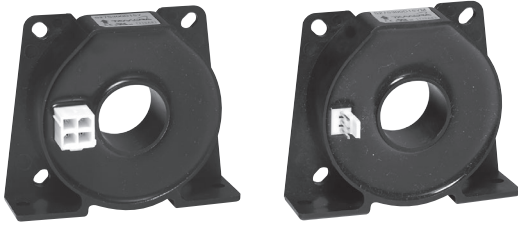

SPECIFICATIONS

Ta=25°C, Vcc=±15V

Spec	Types	S27S300D15Y	S27S300D15YM
Connector	—	39-28-8040 [5566-04A-210] (Molex)	38-00-6293 [6410-03C (102)] (Molex)
Rated Current	If	300A	
Maximum Current Vcc = ± 15V, Ta=85°C	If max	± 500A	
Measuring resistance at Ta=85°C If = [± ADC]	RL	± 12V	300A 0 Ω ~ 39 Ω 500A 0 Ω ~ 12 Ω
		± 15V	300A 0 Ω ~ 58 Ω 500A 0 Ω ~ 22 Ω
		± 20V	300A 15 Ω ~ 93 Ω 500A 15 Ω ~ 45 Ω
Output Current	Io	150mA (Conversion Ratio 1:2000)	
Output Current Accuracy	XG	Io ± 0.4% (without Iof)	
Offset Current	Iof	≦ ± 0.2mA (at If=0A) *1	
Output Linearity	εL	≦ ± 0.1% (at If)	
Power Supply Voltage	Vcc	± 12 ~ ± 20V	
Consumption Current	Icc	≦ ± 20mA (without Io)	
di/dt Response Time (@90% of If)	tr	≦ 1us (di/dt=100A/us)	
Thermal drift of gain	TCIo	≦ ± 0.01%/°C (without TClof)	
Thermal drift of offset	TClof	≦ ± 0.5mA max	
Hysteresis error	Ioh	≦ 0.1mA (at If = 0A → If → 0A)	
Insulation voltage	Vd	AC4000V, for 1minute (sensing current 0.5mA), inside of through hole ⇔ terminal	
Insulation resistance	RIS	≧ 500M Ω (at DC500V) inside of through hole ⇔ terminal	
Ambient Operating temperature	TA	- 40°C ~ + 85°C	
Ambient storage temperature	TS	- 40°C ~ + 90°C	
Secondary coil resistance	RS	25 Ω (Ta=70°C) 28 Ω (Ta=85°C)	

* 1 Offset current value is after removal of core hysteresis.
* Please refer to the another sheet about conditions of UL Recognition.

DIMENSIONS (mm)

S27S300D15Y

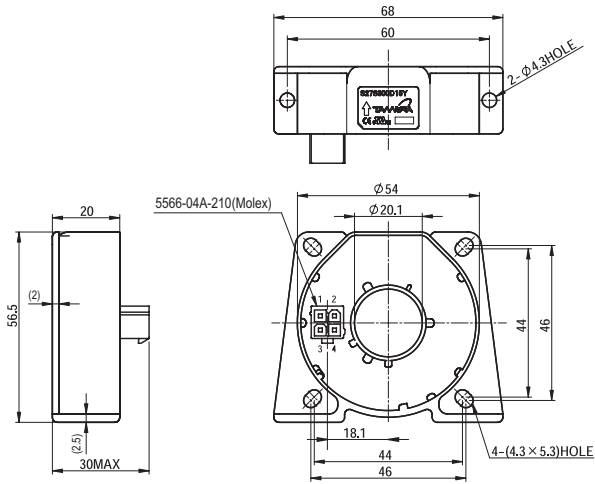

Terminal number

- 1 + Vcc
- 2 Output
- 3 - Vcc
- 4 nc

Weight:

90g typ

Note

1. Unless otherwise specified, tolerances shall be ± 0.5 mm
2. Unit is [mm]

S27S300D15YM

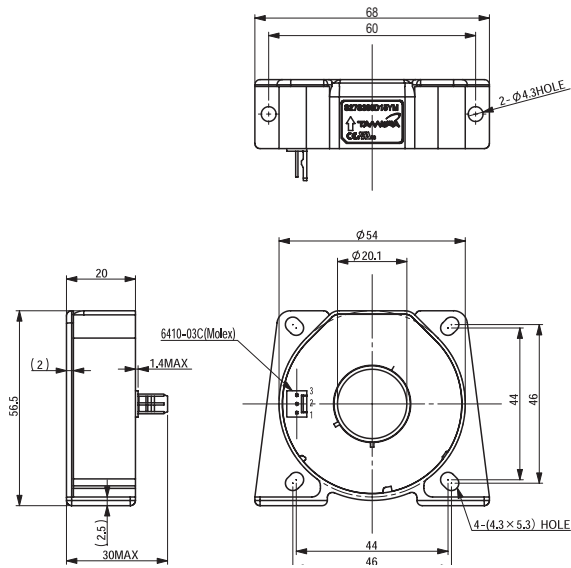

Terminal number

- 1 + Vcc
- 2 Output
- 3 - Vcc

Weight:

90g typ

Note

1. Unless otherwise specified, tolerances shall be ± 0.5 mm
2. Unit is [mm]

Servo system Current-output type

S28S SERIES

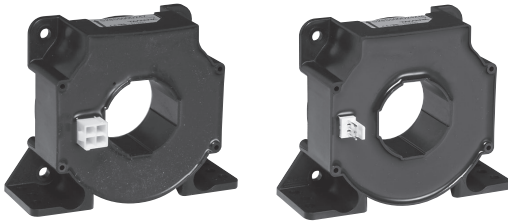

SPECIFICATIONS

Ta=25°C, Vcc=±24V

Spec	Types	Symbol	S28S500D24Z	S28S500D24ZM
Connector		—	39-28-8040 [5566-04A-210] (Molex)	38-00-6293 [6410-03C (102)] (Molex)
Rated Current		If	500A	
Maximum Current		If max	± 800A	
Measuring resistance	R _L	± 15V	500A 0Ω~ 60Ω 800A 0Ω~ 11Ω	
		± 18V	500A 0Ω~ 92Ω 800A 0Ω~ 30Ω	
		± 24V	500A 5Ω~ 149Ω 800A 5Ω~ 65Ω	
Output Current		Io	100mA (Conversion Ratio 1:5000)	
Output Current Accuracy		X _G	Io ± 0.5% (without Iof)	
Offset Current		Iof	≤ ± 0.4mA (at If = 0A) *1	
Output Linearity (0A ~ If)		ε _L	≤ ± 0.1%	
Power Supply Voltage		Vcc	± 15 ~ ± 24V	
Consumption Current		Icc	≤ ± 30mA (at If = 0A) *Icc = 25 + If / 5000	
di/dt Response Time (@90% of If)		tr	≤ 1us (di/dt=100A/us)	
Output Temperature Characteristic		TClo	≤ ± 0.01%/°C (Without TClof)	
Offset Temperature Characteristic		TClof	≤ ± 0.4mA max	
Hysteresis allowance		I _{oH}	≤ ± 0.2mA max (at If = 0A → 3*If → 0A)	
Insulation Withstanding		Vd	AC4,000V, for 1minute (sensing current 0.5mA) inside of through hole ⇔ terminal	
Insulation Withstanding		R _{is}	≥ 500MΩ (at DC500V) inside of through hole ⇔ terminal	
Operating Temperature		T _A	- 40°C ~ + 70°C	
Storage Temperature		T _S	- 40°C ~ + 85°C	
Secondary coil resistance		Rs	70Ω (Ta=70°C)	

* 1 Offset current value is after removal of core hysteresis.
* Please refer to the another sheet about conditions of UL Recognition.

DIMENSIONS (mm)

S28S500D24Z

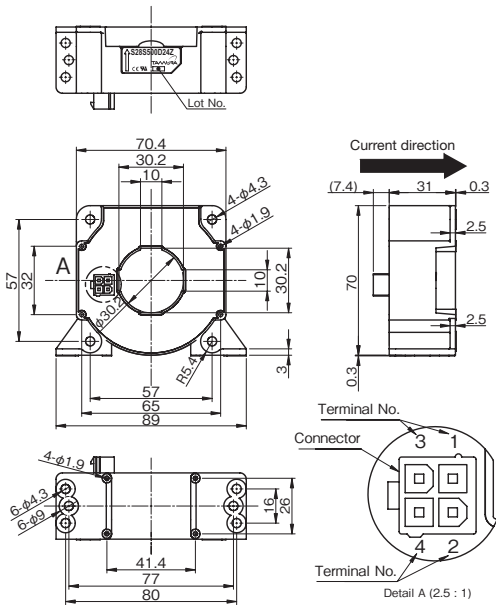

Terminal number

- 1 NC
- 2 - Vcc
- 3 OUT
- 4 + Vcc

Weight:
260g typ

Connector

Manufacturer	Part Number	Old Part Number
Molex	39-28-8040	5566-04A-210

Note

1. Unless otherwise specified, tolerances shall be $\pm 0.5\text{mm}$
2. Unit is [mm]

S28S500D24ZM

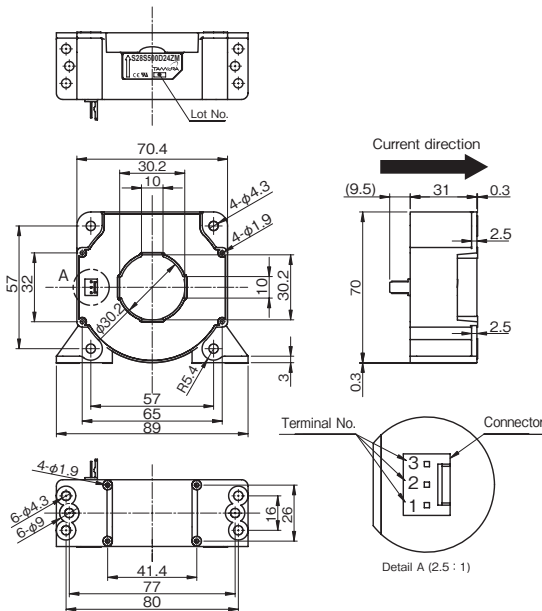

Terminal number

- 1 + Vcc
- 2 OUT
- 3 - Vcc

Weight:
260g typ

Connector

Manufacturer	Part Number	Old Part Number
Molex	38-00-6293	6410-03C (102)

Note

1. Unless otherwise specified, tolerances shall be $\pm 0.5\text{mm}$
2. Unit is [mm]

Servo system Current-output type

S29S D24 SERIES

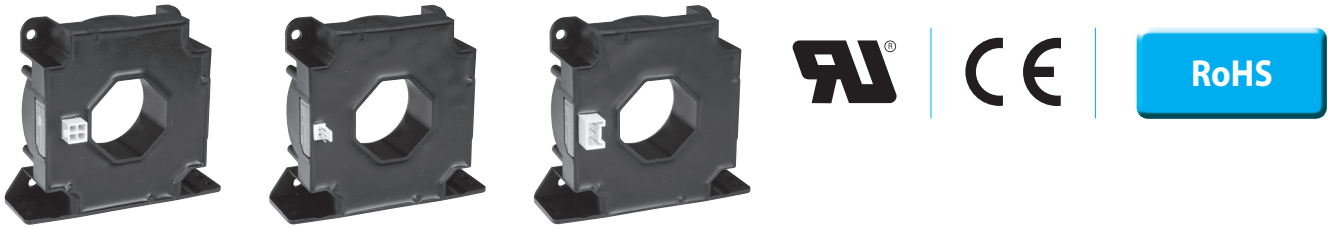

SPECIFICATIONS

Ta=25°C, Vcc=±24V

Spec	Types	Symbol	S29S1T0D24Z	S29S1T0D24ZM	S29S1T0D24ZJ
Connector	—		39-28-8040 [5566-04A-210] (Molex)	38-00-6293 [6410-03C (102)] (Molex)	BH3P-VH-1 (JST)
Rated current	If		1000A		
Maximum current 3sec	If max		± 2100A		
Measuring resistance	RL	± 15V	70°C	1000A 0Ω~ 21Ω 1200A 0Ω~ 9Ω 1300A 0Ω~ 5Ω	
			85°C	1000A 0Ω~ 18Ω 1200A 0Ω~ 7Ω	
		± 24V	70°C	1000A 0Ω~ 60.5Ω 1800A 0Ω~ 14Ω 2100A 0Ω~ 4Ω	
			85°C	1000A 10Ω~ 58.5Ω 1800A 10Ω~ 12Ω	
Output current	Io		200mA (Conversion Ratio 1:5000)		
Output current accuracy	XG		Io ± 0.4% (without Iof)		
Offset current	Iof		≤± 0.4mA (at If=0A) * 1		
Output linearity	εL		≤± 0.1% (at If)		
Power supply voltage	Vcc		± 15V (± 5%) ~± 24V (± 5%)		
Consumption current	Icc		≤± 35mA (Without Io)		
di/dt response time (@90% of If)	tr		≤ 1us (di/dt=100A/us)		
Thermal drift of gain	TClO		≤± 0.01%/°C (without TClOf)		
Thermal drift of offset	TClOf		≤± 0.5mA max (at - 10°C~+ 70°C) ≤± 0.8mA max (at - 40°C~+ 85°C)		
Hysteresis error	Ioh		≤± 0.2mA (at If=0A ⇒ 3 × If ⇒ 0A)		
Insulation withstanding	Vd		AC4,000V, for 1minute (sensing current 0.5mA) ,inside of through hole ⇔ terminal		
Insulation resistance	Ris		≥ 500MΩ (at DC500V) inside of through hole ⇔ terminal		
Ambient Operating temperature	TA		- 40°C~+ 85°C		
Ambient storage temperature	TS		- 40°C~+ 90°C		
Secondary coil resistance	Rs		48Ω (Ta=70°C) 50Ω (Ta=85°C)		

* 1 Offset current value is after removal of core hysteresis. * Temperature of the primary conductor(busbar) should not exceed 100°C .
* Please refer to the another sheet about conditions of UL Recognition.

DIMENSIONS (mm)

S29S1T0D24Z

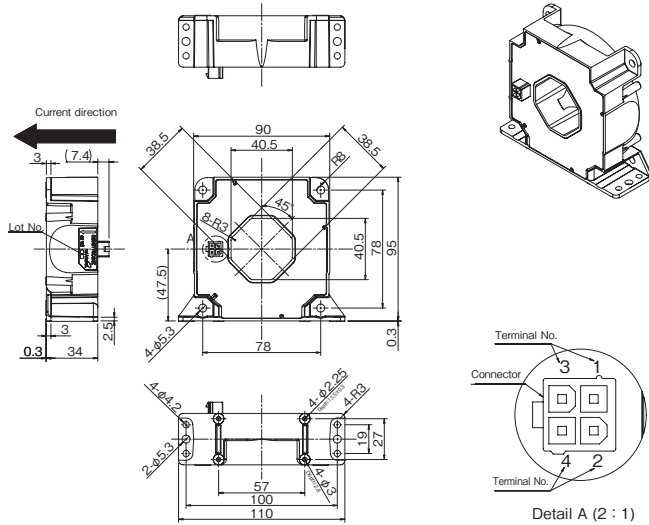

Terminal number

- 1 NC (No connection)
- 2 +Vcc (+24V)
- 3 -Vcc (-24V)
- 4 Iout

Connector		
Manufacturer	Part Number	Old Part Number
Molex	39-28-8040	5566-04A-210

Plating of terminal; Sn

Weight

560g typ

Note

- 1. Unless otherwise specified, tolerances shall be $\pm 0.5\text{mm}$
- 2. Unit is [mm]

S29S1T0D24ZM

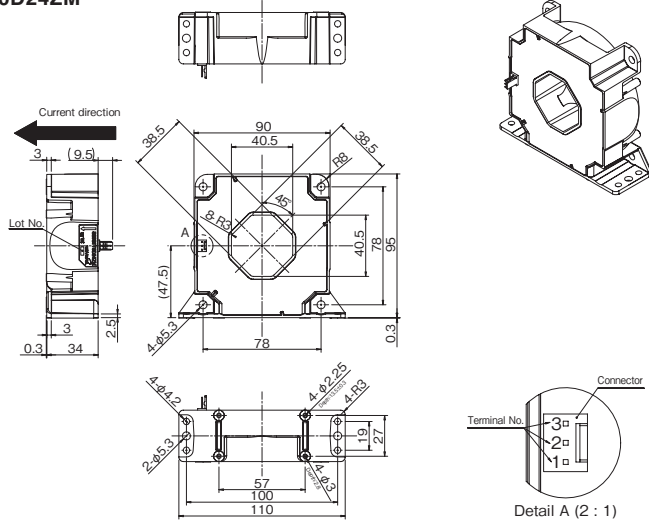

Terminal number

- 1 +Vcc (+24V)
- 2 Iout
- 3 -Vcc (-24V)

Connector		
Manufacturer	Part Number	Old Part Number
Molex	38-00-6293	6410-03C (102)

Plating of terminal; Sn

Weight

560g typ

Note

- 1. Unless otherwise specified, tolerances shall be $\pm 0.5\text{mm}$
- 2. Unit is [mm]

S29S1T0D24ZJ

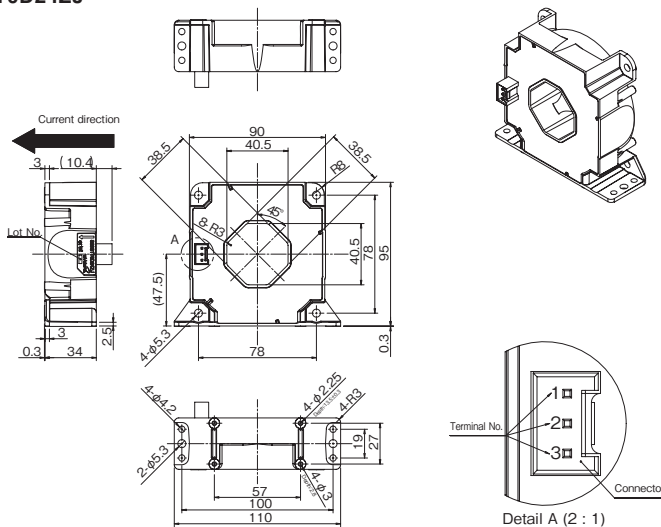

Terminal number

- 1 -Vcc (-24V)
- 2 Iout
- 3 +Vcc (+24V)

Connector	
Manufacturer	Part Number
JST	BH3P-VH-1

Plating of terminal; Sn

Weight

560g typ

Note

- 1. Unless otherwise specified, tolerances shall be $\pm 0.5\text{mm}$
- 2. Unit is [mm]

Servo system Current-output type

S30S D24 SERIES



ABSOLUTE MAXIMUM RATINGS

Parameters	Symbol	Unit	Value	Remarks
Maximum Supply voltage	V _{CC}	V	± 25.2	
Primary conductor temperature	T _B	°C	100	

ISOLATION CHARACTERISTICS

Parameters	Symbol	Unit	Value	Remarks	
Insulation voltage	V _d	kVrms	AC6700V, for 1minute (Sensing current 0.5mA)	Primary ⇔ Secondary	
Impulse withstand voltage	V _w	kV	23	Primary ⇔ Secondary Input waveform : • Front time 1.2μs • Time to half value 50μs • single	
Insulation resistance	R _{IS}	—	≥ 500M Ω (at DC500V)	Primary ⇔ Secondary	
Clearance distance	d _{Cl}	—	min : 12.1 (min : 30.4)	Primary ⇔ Secondary (Busbar ⇔ ConnectorPWB)	
Creepage distance	d _{CP}	—	min : 35.5 (min : 33.0)	Primary ⇔ Secondary (Busbar ⇔ ConnectorPIN)	
Case material	—	—	UL94 V-0		
Filler material	—	—	UL94 V-0		
Comparative Tracking Index : (CTI)	Case	CTI	V	400 ~ 599 (Group II)	
	Filler	CTI	V	600 (Group I)	
Application example	—	—	2.475kVa.c ,CAT III , PD2	Reinforced isolation, non uniform field according to EN50178 : 1997	
	—	—	1kVa.c 1.5kVd.c ,CAT III , PD2	Reinforced isolation, non uniform field according to EN62477-1 : 2012 and EN62477-1 : 2012/A11 2014	

ENVIRONMENTAL AND MECHANICAL CHARACTERISTICS

Parameters	Symbol	Unit	Value			Remarks
			MIN	TYP	MAX	
Ambient operating temperature	T _A	°C	- 40	—	+ 85	
Ambient storage temperature	T _S	°C	- 40	—	+ 90	
Mass	m	kg	—	1.3	—	

SPECIFICATIONS

T_A=+25°C, R_M=1Ω, V_{CC}=±24V

Parameters	Symbol	Unit	Value			Remarks
			MIN	TYP	MAX	
Primary nominal current	I _{PN}	A	—	2000	—	
Primary current, measuring range * 1,2	I _{PM}	A	3500	—	—	at Ta=+85°C, Vcc= ± 22.8Vmin, RM=1ohm, t=2sec
Measuring resistance * 1	R _M	Ω	0	—	—	See Fig1
Conversion ratio	K _N	—	—	1 : 5000	—	
Output current @I _{PN}	I _o	mA	—	400	—	I _o = I _{PN} / 5000. Without I _{of} .
Accuracy @I _{PN}	X	%	- 0.2	0.0	+ 0.2	T _A =25°C~ 85°C, Without I _{of} .
			- 0.3	0.0	+ 0.3	T _A = - 40°C~ 85°C, Without I _{of} .
Offset current * 3	I _{of}	mA	- 0.2	0.0	+ 0.2	at I _p = 0A.
Linearity error (0A ~ I _{PN})	ε _L	%	- 0.1	0.0	+ 0.1	
Hysteresis error	I _{OH}	mA	- 0.2	0.0	+ 0.2	at I _p = 0A → I _{PN} → 0A
Supply voltage	V _{CC}	V	± 15 (± 5%)	± 24 (± 5%)		
Consumption current	I _{CC}	mA	—	45	—	at I _p = 0A. I _{CC} = 45 + I _p / 5000.
Response time @90% of I _{PN} * 4	t _r	μs	—	0.5	—	di/dt=100A/μs
Frequency bandwidth (- 3dB) * 5	BW	kHz	—	150	—	See Fig2, at very low current
Temperature coefficient of I _{of} * 3	T _{cIof}	μA/°C	- 4.8	0	+ 4.8	at I _p = 0A
Secondary coil resistance	R _s	Ω	—	—	24.5	T _A = + 85°C

- * 1 Current sensor has limited operating time depending on the measured resistance and maximum current. Internal circuits can become corrupted if you used beyond the limited time.
- * 2 The value of measured current which indicates an output with a greater than ± 5% deviation from the theoretical output value.
- * 3 Offset current is measured after removal of the hysteresis.
- * 4 Measurement condition : Primary conductor cross sectional area is as same as through hole, and penetration with 1turn in through hole.
- * 5 High fundamental frequency primary current and/or harmonic current may result in excessive heating in magnetic core (Silicon steel).

STANDARDS

EN50178:1997, EN62477-1 : 2012 and EN62477-1 : 2012/A11 2014, UL508 (No.E243511), CSA22.2 No.14-13
 ※ Please refer to the another sheet about conditions of UL Recognition.

TYPICAL CHARACTERISTIC CURVES

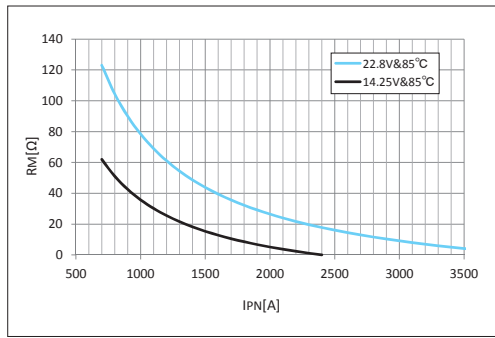

Figure 1 : Maximum Measuring Resistance

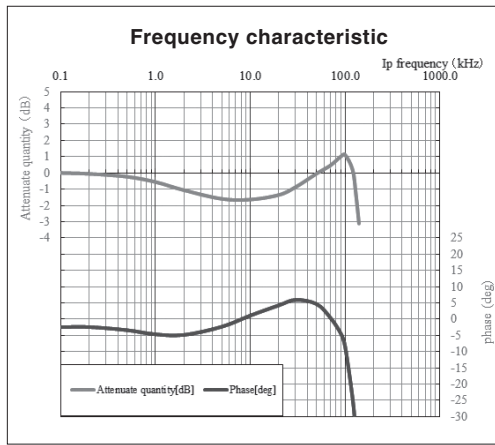

Figure 2 : Frequency response curve

CONNECTION

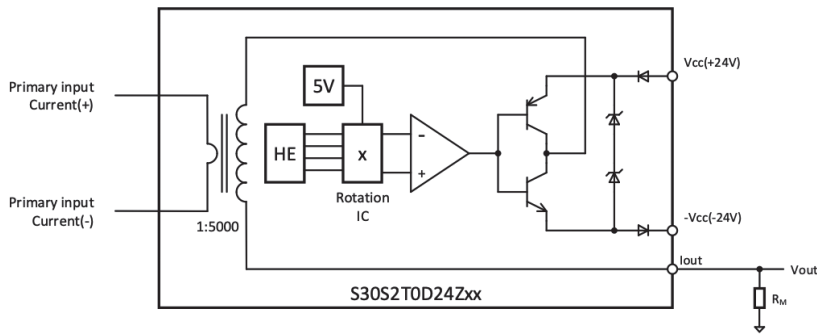
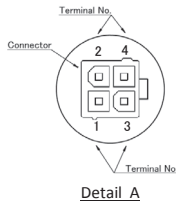
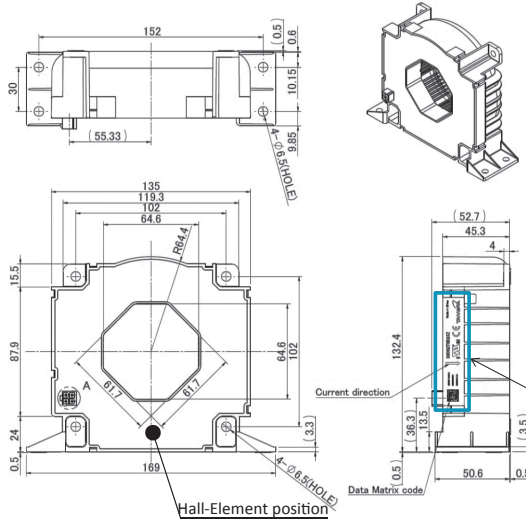

Figure 3 : Block diagram

DIMENSIONS (mm)

S30S2T0D24Z



Terminal number
 1 Vcc (+24V)
 2 Iout
 3 -Vcc (-24V)
 4 N.C.
 Tolerance : ±0.5
 Unit : mm

Connector		
Maker	PartsNo.	old parts No.
Molex	39-28-8040	5566-04A-210

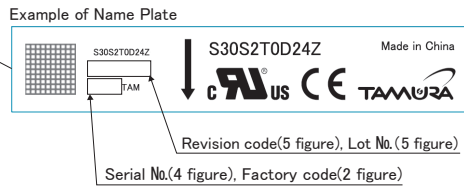

S30S2T0D24ZM

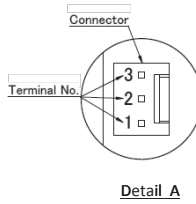
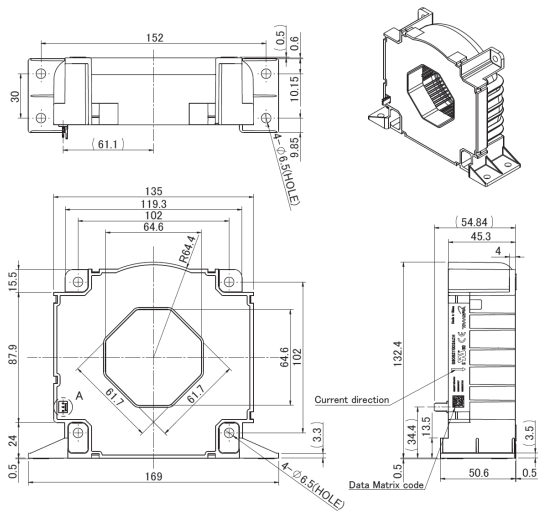

Terminal number
 1 Vcc (+24V)
 2 Iout
 3 -Vcc (-24V)
 Tolerance : ±0.5
 Unit : mm

Connector		
Maker	PartsNo.	old parts No.
Molex	38-00-6293	AE-6410-03C(197)

S30S2T0D24ZJ

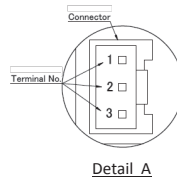
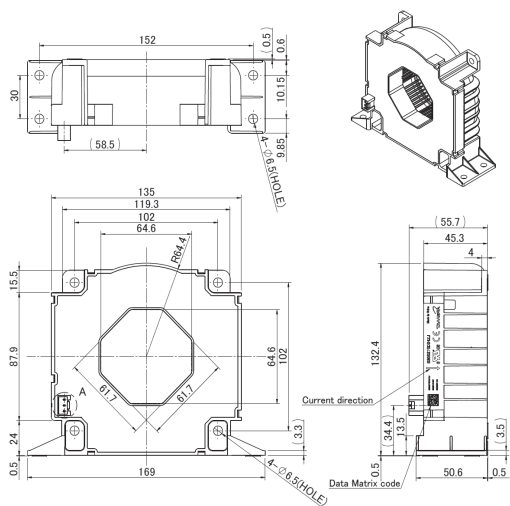

Terminal number
 1 -Vcc (-24V)
 2 Iout
 3 Vcc (+24V)
 Tolerance : ±0.5
 Unit : mm

Connector		
Maker	PartsNo.	old parts No.
JST	BH3P-VH-1	-

Introduction
Fluxgate system
Open loop
Closed loop

Servo system Current-output type

S42S D24 SERIES



ABSOLUTE MAXIMUM RATINGS

Parameters	Symbol	Unit	Value	Remarks
Maximum Supply voltage	V _{cc}	V	± 25.2	
Primary conductor temperature	T _B	°C	100	

ISOLATION CHARACTERISTICS

Parameters	Symbol	Unit	Value	Remarks	
Insulation voltage	V _d	—	AC4400V, for 1minute (Sensing current 0.5mA)	Primary ⇔ Secondary	
Impulse withstand voltage	V _w	kV	12	Primary ⇔ Secondary Input waveform : · Front time 1.2μs · Time to half value 50μs · single	
Insulation resistance	R _{IS}	MΩ	≥ 500M Ω (at DC500V)	Primary ⇔ Secondary	
Clearance distance	d _{cl}	mm	min : 7.3 (min : 14.0)	Primary ⇔ Secondary (Busbar ⇔ ConnectorPWB)	
Creepage distance	d _{cp}	mm	min : 9.3 (min : 18.2)	Primary ⇔ Secondary (Busbar ⇔ ConnectorPIN)	
Case material	—	—	UL94 V-0		
Filler material	—	—	UL94 V-0		
Comparative Tracking Index : (CTI)	Case	CTI	V	400 ~ 599 (Group II)	
	Filler	CTI	V	600 (Group I)	
Application example	—	—	1kVa.c ,CAT III , PD2 1.5kVd.c	Reinforced isolation, non uniform field according to EN62477-1 : 2012 and EN62477-1 : 2012/A11 2014	

ENVIRONMENTAL AND MECHANICAL CHARACTERISTICS

Parameters	Symbol	Unit	Value			Remarks
			MIN	TYP	MAX	
Ambient operating temperature	T _A	°C	- 40	—	+ 85	
Ambient storage temperature	T _S	°C	- 40	—	+ 90	
Mass	m	g	—	400	—	

SPECIFICATIONS

T_A=+25°C, R_M=1Ω, V_{CC}=±24V

Parameters	Symbol	Unit	Value			Remarks
			MIN	TYP	MAX	
Primary nominal current	I _{PN}	A	—	1000	—	
Primary current, measuring range * 1,2	I _{PM}	A	2100	—	—	at T _A = + 85°C, V _{CC} = ± 22.8V, R _M =1 Ω, t=4sec
Measuring resistance * 1	R _M	Ω	0	—	—	See Fig1
Conversion ratio	K _N	—	—	1 : 5000	—	
Output current @I _{PN}	I _O	mA	—	200	—	I _O = I _{PN} /5000. Without I _{of} .
Accuracy @I _{PN}	X	%	- 0.2	0.0	+ 0.2	T _A =25°C~+ 85°C, Without I _{of} .
			- 0.3	0.0	+ 0.3	T _A = - 40°C~+ 85°C, Without I _{of} .
Offset current * 3	I _{of}	mA	- 0.2	0.0	+ 0.2	at I _p = 0A.
Linearity error (0A ~ I _{PN})	ε _L	%	- 0.1	0.0	+ 0.1	
Hysteresis error	I _{OH}	mA	- 0.2	0.0	+ 0.2	at I _p = 0A → I _{PN} → 0A
Supply voltage	V _{CC}	V	± 15 (± 5%)	± 24 (± 5%)		
Consumption current	I _{CC}	mA	—	45	—	at I _p = 0A. I _{CC} = 45 + I _p /5000.
Response time @90% of I _{PN} * 4	t _r	μs	—	0.5	—	di/dt=100A/μs
Frequency bandwidth (- 3dB) * 5	BW	kHz	—	150	—	at very low current
Temperature coefficient of I _{of} * 3	T _{cIof}	μA/°C	- 4.8	0	+ 4.8	at I _p = 0A
Secondary coil resistance	R _S	Ω	—	—	47.5	T _A = + 85°C

- * 1 Current sensor has limited operating time depending on the measured resistance and maximum current. Internal circuits can become corrupted if you used beyond the limited time.
- * 2 The value of measured current which indicates an output with a greater than ± 5% deviation from the theoretical output value.
- * 3 Offset current is measured after removal of the hysteresis.
- * 4 Measurement condition : Primary conductor cross sectional area is as same as through hole, and penetration with 1turn in through hole.
- * 5 High fundamental frequency primary current and/or harmonic current may result in excessive heating in magnetic core (Silicon steel).

STANDARDS

EN62477-1 : 2012 and EN62477-1 : 2012/A11 2014, UL508 (No.E243511) , CSA22.2 No.14-13

* Please refer to the another sheet about conditions of UL Recognition.

TYPICAL CHARACTERISTIC CURVES

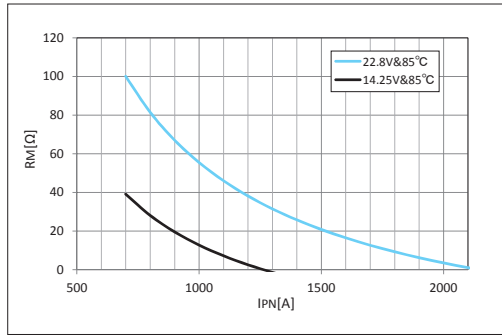
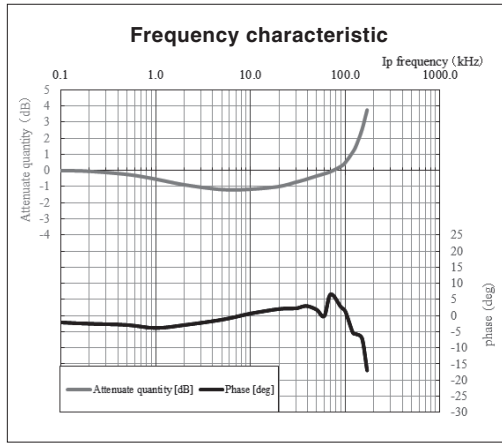

Figure 1 : Maximum Measuring Resistance



Measurement conditions:
 $T_A = +25^\circ\text{C}$, $R_M = 2.4 \Omega$, $I_P = 3A * 20T$, $V_{CC} = \pm 24V$

Figure 2 : Frequency response curve

CONNECTION

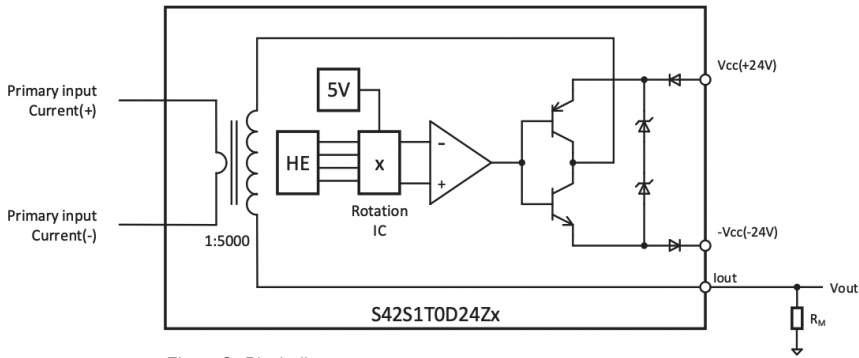
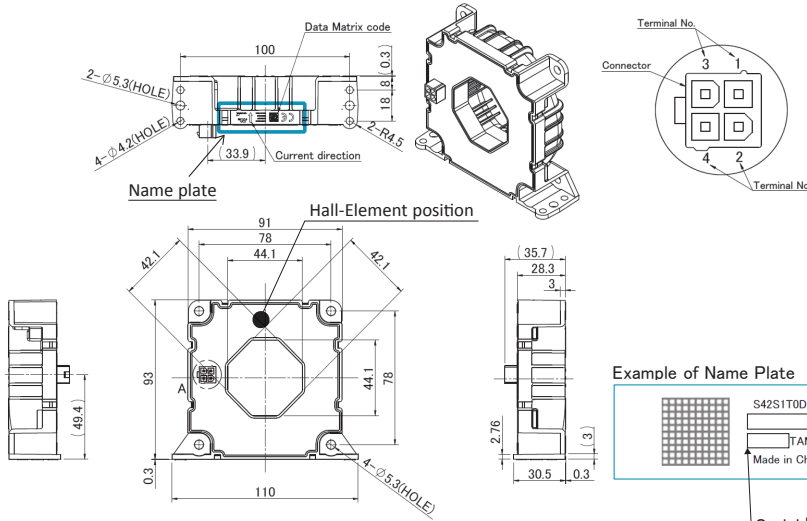

Figure 3 : Block diagram

DIMENSIONS (mm)

S42S1T0D24Z



Terminal number

- 1 N.C
- 2 Vcc (+24V)
- 3 -Vcc (-24V)
- 4 Iout

Tolerance : ±0.5
Unit : mm

Connector		
Maker	PartsNo.	old parts No.
Molex	39-28-8040	5566-04A-210

S42S1T0D24ZM

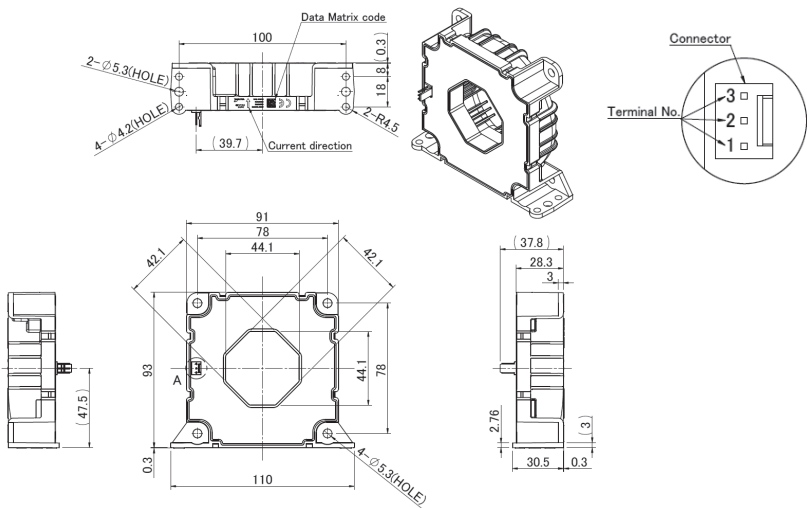

Terminal number

- 1 Vcc(+24V)
- 2 Iout
- 3 -Vcc(-24V)

Tolerance : ±0.5
Unit : mm

Connector		
Maker	PartsNo.	old parts No.
Molex	38-00-6293	AE-6410-03C(197)

S42S1T0D24ZJ

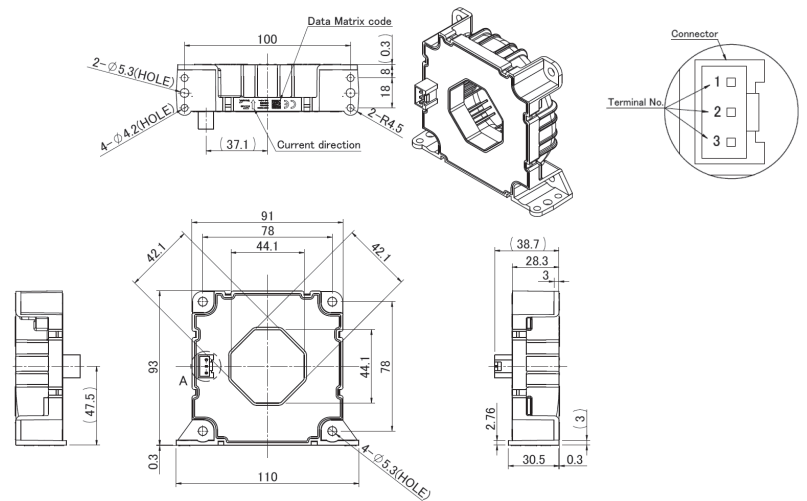

Terminal number

- 1 -Vcc(-24V)
- 2 Iout
- 3 Vcc(+24V)

Tolerance : ±0.5
Unit : mm

Connector		
Maker	PartsNo.	old parts No.
JST	BH3P-VH-1	-

TAMURA CORPORATION

<https://www.tamuracorp.com/electronics/en/>



HEAD OFFICE

1-19-43, Higashi-Oizumi, Nerima-ku, Tokyo, 178-8511 Japan

SAKADO OFFICE

5-5-30 Chiyoda Sakado-shi Saitama 350-0214 Japan
Tel : 050-3664-0495/050-3664-0496 Fax : 049-284-9183

OSAKA SALES OFFICE

Esaka-Sanshoubill 3-27-27 Tarumi-cho Suita-shi Osaka 564-0062 Japan
Tel : 050-3664-0550 Fax : 06-6385-8371

NAGOYA SALES OFFICE

3-1803, Kamiyashiro, Meito-ku, Nagoya-shi, Aichi, 465-0025 Japan
Tel : 050-3664-0559 Fax : 052-701-1295

TAMURA CORPORATION OF CHINA LIMITED

13F, Block A, International Shopping Centre Shanghai No.527
Huaihai Zhong Road, Shanghai, China
Tel : 86-21-6387-9388 Fax : 86-21-6387-9268

TAMURA ELECTRONICS(S.Z.)CO.,LTD.

101, No. 30-6, Rhine Road, Xinsheng Community, Longgang
Street, Longgang District, Shenzhen, 518116 China
Tel : 86-755-8950-2707

Taiwan Tamura Technology Co., Ltd.

New Taipei Office (Components)

13F, No.866, Chung Cheng Road, Chung Ho District,
New Taipei City, Taiwan
Tel : 886-2-8228-2001 Fax : 886-2-8228-2002

TAMURA CORPORATION OF KOREA

513, Hyundai I-Valley 31, Galmachi-ro 244 beon-gil, Jungwon-gu,
Seongnam-si Gyeonggi-do, 13212 Korea
Tel : 82-2-489-5354 Fax : 82-2-489-5360

TAMURA CORPORATION (THAILAND) CO., LTD.

1858/120 Interlink Tower 27th floor, Debaratna Road, Bangna Tai,
Bangna, Bangkok 10260, Thailand
Tel : 66-2316-2270 Fax : 66-2316-2274

TAMURA ELECTRONICS(M)SDN.BHD.

No. 2, Jalan Halba 16/16, Seksyen 16, 40200 Shah Alam,
Selangor, Malaysia
Tel : 60-3-5525-6000 Fax : 60-3-5510-1013

TAMURA CORPORATION OF AMERICA

277 Rancheros Drive #190 San Marcos, CA 92069 U.S.A.
Tel : 1-760-871-2009 Fax : 1-760-740-0536

TAMURA EUROPE LIMITED.

Clark Avenue Porte Marsh Industrial Estate Calne Wiltshire
SN11 9BS United Kingdom
Tel : 44(0)-1380-731-700 Fax : 44(0)-1380-731-703

