



WBA3050-30A

3 - 5 GHz LOW NOISE WIDE BAND AMPLIFIER

REV B
April 2009

Key Features



- 3 ~ 5 GHz
- 0.90 dB noise figure
- 30.0 dB Gain
- +/-0.30 dB Gain Flatness
- 2.0 dBm P_{1dB}
- 1.5:1 VSWR
- Single Power Supply
- >34 years MTBF
- Unconditional stable
- RoHS compliant

Product Description

WBA3050-30A integrates WanTcom proprietary low noise amplifier technology, high frequency micro electronic assembly techniques, and high reliability design to realize optimum low noise figure, wideband, high linearity, and unconditional stable performances together. With single +5.0V DC operation, the amplifier has optimal input and output matching in the specified frequency range at 50-Ohm impedance system. The amplifier has standard field replaceable SMA gold plated housing.

The amplifier is designed to meet the rugged standard of MIL-STD-202.

Applications

- Mobile Infrastructures
- GPS
- C-band
- WiMAX
- Security System
- Measurement
- Fixed Wireless



Specifications

Summary of the electrical specifications WBA3050-30A at room temperature

Index	Testing Item	Symbol	Test Constraints	Min	Nom	Max	Unit
1	Gain	S ₂₁	3 – 5 GHz		30		dB
2	Gain Variation	ΔG	3 – 5 GHz		+/- 0.3	+/-0.50	dB
3	Input VSWR	SWR ₁	3 – 5 GHz		1.5:1	1.7:1	Ratio
4	Output VSWR	SWR ₂	3 – 5 GHz		1.35:1	1.5:1	Ratio
5	Reverse Isolation	S ₁₂	3 – 5 GHz		50		dB
6	Noise figure	NF	3 – 5 GHz		0.90	1.2	dB
7	Output Power 1dB compression Point	P _{1dB}	3 – 5 GHz		2.0	3.0	dBm
8	Current Consumption	I _{dd}	V _{dd} = +5 V		45		mA
9	Power Supply Voltage	V _{dd}	WBA3050-30A	+4.7	+5	+5.3	V
10	Thermal Resistance	R _{th,c}	Junction to case			220	°C/W
11	Operating Temperature	T _o		-40		+85	°C
12	Maximum Average RF Input Power	P _{IN, MAX}	DC – 12 GHz			5	dBm

Absolute Maximum Ratings

Parameters	Units	Ratings
DC Power Supply Voltage	V	6.0
Drain Current	mA	80
Total Power Dissipation	mW	400
RF Input Power	dBm	5
Channel Temperature	°C	150
Storage Temperature	°C	-55 ~ 125
Operating Temperature	°C	-40 ~ 85
Thermal Resistance	°C/W	220

Operation of this device above any one of these parameters may cause permanent damage.

Functional Block Diagram

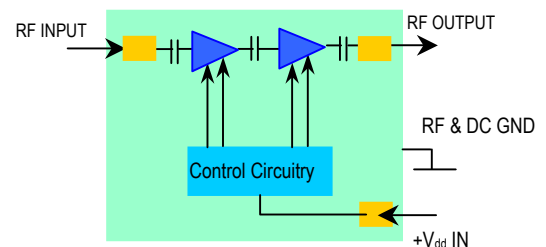

Ordering Information

Model Number	WBA3050-30A
--------------	-------------

Preliminary

Specifications and information are subject to change without notice.



WBA3050-30A

3 - 5 GHz LOW NOISE WIDE BAND AMPLIFIER

REV B
April 2009

Typical Data

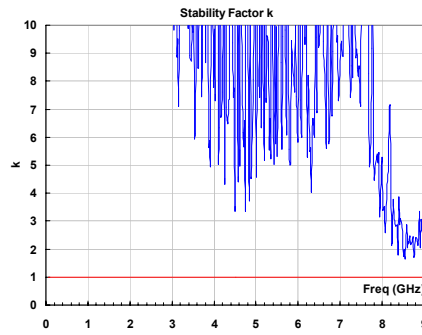
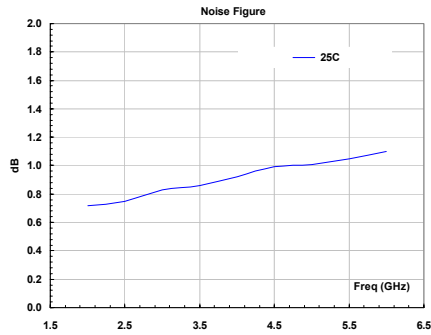
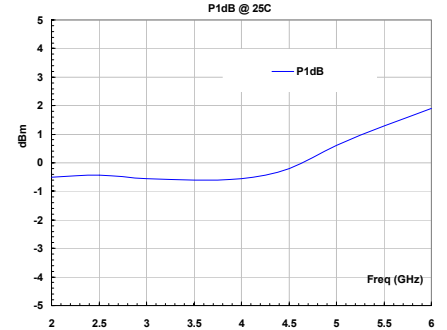
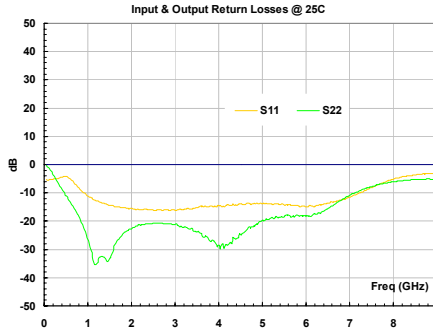
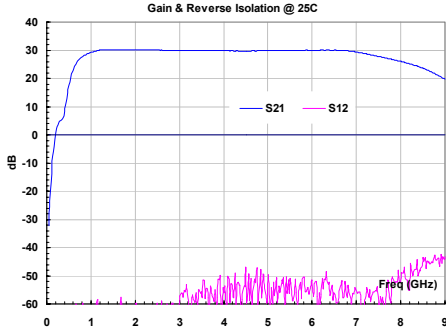

Outline,

UNITS: INCH [mm]
 BODY: Brass
 Finish: Gold Plating
 RF Connector: SMA F Gold
 V_{dd} PWR: Feed through

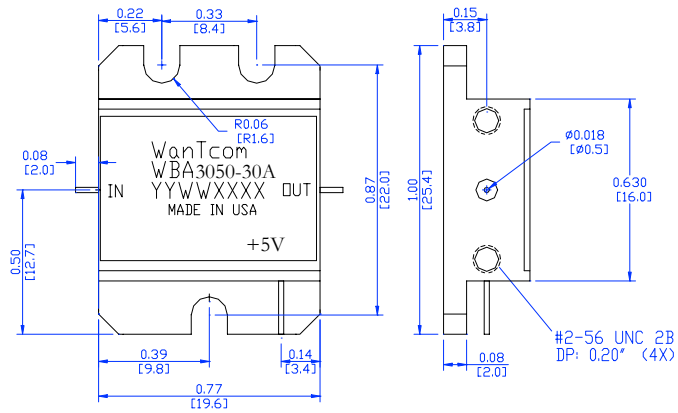

Specifications and information are subject to change without notice.

WanTcom, Inc * Phone 01 952 746 6088 * FAX: 01 952 746 8818 * e-mail: sales@wantcominc.com * Web site: www.wantcominc.com



Application Notes:

A. SMA Torque Wrench Selection

Always use a torque wrench with 5 ~ 6 inch-lb coupling torque setting for mating the SMA cables to the amplifier. Never use torque more than 8 inch-lb wrench for tightening the mating cable to the connector. Otherwise, the permanent damage will occur to the SMA connectors of the amplifier. 8710-1582 (5 inch-lb) is one of the ideal torque wrench choice from Agilent Technology.

B. DC Power Line Connection

Strip the insulation layer at the end of DC power supply wire. The stripped distance should be in the range of 0.100" to 0.200". The 24 ~ 26 American Wire Gauge wire is suitable. Wound the stripped terminal wire about 1 to 2 turns on the DC feed thru center pin. Solder the wounded wire and the center pin together. Clean the soldering area by Q-tip with alcohol to remove the flux and residue.

Repeat the process to solder the DC return wire on the ground turret.

C. Mounting the Amplifier

Use three pieces of #4-40 with longer than 9/16" screws for mounting the amplifier on a metal-based chase. Flat and spring washers are needed to prevent the screw loosening during the shock and vibration. Always use the appropriate torque setting of the power screwdriver to mount them.
