



WMA08A

8.5 MHz LOW NOISE PRE-AMPLIFIER

REV B
July 2016

Key Features



- 50 Ohm Source Impedance
- Frequency of 8.5 MHz
- 3.8 Ohm Input Impedance
- 1.2 dB Noise Figure
- 30.0 dBm Max P_{IN}
- 25.0 dBm Output IP₃
- 28.0 dB Gain
- 15.0 dBm P_{1dB}
- 1.22:1 Output VSWR
- Unconditional Stable, $k > 1$
- Single Power Supply
- None Magnetic

Product Description

WMA08A is integrated with WanTcom proprietary low noise amplifier technologies, high frequency micro electronic assembly techniques, and high reliability designs to realize optimum low noise figure, wideband, and high performances together. With single +10.0V DC operation, the amplifier has 3.8 Ohm input impedance and unconditional stable condition. The amplifier has 0.18" x 0.40" x 0.10" surface mount package.



Applications

- Magnetic Resonance Imaging
- RF Measurement
- Medical
- Current Sensor



Other frequencies and impedance available!

Specifications

Summary of the key electrical specifications at room temperature, tested in the WanTcom fixture, 80051.

| Index | Testing Item | Symbol | Test Constraints | Min | Nom | Max | Unit |
|-------|---------------------------------------|-----------------------|---|------|------|---------|-------|
| 1 | Gain | S ₂₁ | 8.5 MHz | 27.5 | 28.0 | 28.5 | dB |
| 2 | Gain Variation | ΔG | 8.5 +/- 1 MHz | | | +/- 0.1 | dB |
| 3 | Input Impedance | RE [Z _{in}] | 8.5 MHz | 3.0 | 3.8 | 4.5 | Ohm |
| | | IM [Z _{in}] | 8.5 MHz | -3.0 | 0 | 3.0 | Ohm |
| 4 | Output VSWR, 50 Ohm Impedance | SWR ₂ | 8.5 MHz | | | 1.22:1 | Ratio |
| 5 | Reverse Isolation | S ₁₂ | 8.5 MHz | 55 | 60 | | dB |
| 6 | Noise Figure | NF | 8.5 MHz, estimated per NF data at 10 MHz | | 1.2 | 1.5 | dB |
| 7 | Output Power 1dB Compression Point | P _{1dB} | 8.5 MHz | 10 | 15 | | dBm |
| 8 | Output-Third-Order Interception Point | IP ₃ | Two-Tone, P _{out} = 0 dBm each, 1 MHz separation | 20 | 25 | | dBm |
| 9 | Current Consumption | I _{dd} | V _{dd} = +10.0 V | | 18 | | mA |
| 10 | Power Supply Operating Voltage | V _{dd} | | +7 | +10 | +12 | V |
| 11 | Thermal Resistance | R _{th,c} | Junction to case | | | 220 | °C/W |
| 12 | Operating Temperature | T _o | | +10 | | +18 | °C |
| 13 | Maximum Input CW RF Power | P _{IN,MAX} | DC – 6.0 GHz, 10% Duty Cycle, | | | 30 | dBm |
| 14 | Saturate Recover Time | t _{sr} | 10% to 90% from 30 dBm Pin | | 8 | 10 | uS |
| 15 | ESD Protection, None Contact | V _{ESDN} | Input/Output Ports | | | 16 | kV |
| 16 | ESD Protection, Direct Contact | V _{ESD} | Input/Output Ports | | | 6 | kV |

Absolute Maximum Ratings

| Parameters | Units | Ratings |
|-----------------------------------|-------|-----------|
| DC Power Supply Voltage | V | 15.0 |
| Drain Current | mA | 30 |
| Total Power Dissipation | mW | 350 |
| Input CW RF Power, 10% Duty Cycle | dBm | 30 |
| Channel Temperature | °C | 150 |
| Storage Temperature | °C | -65 ~ 150 |
| Operating Temperature | °C | 0 ~ +70 |
| Thermal Resistance ¹ | °C/W | 215 |

Operation of this device beyond any one of these parameters may cause permanent damage.

Functional Block Diagram

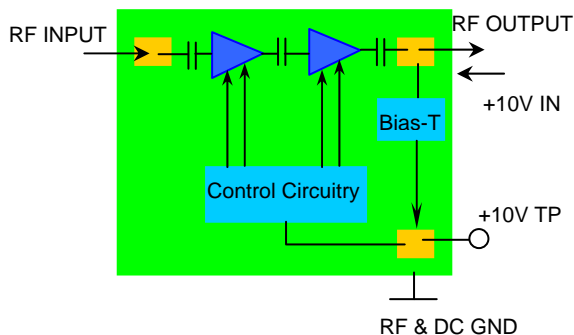

¹ The last stage transistor dominates the heat dissipation. The drain bias voltage is +6V and the drain current is 15.0 mA. The total power dissipation of the last stage transistor is thus 90 mW. The junction temperature rise is 0.09 x 215 = 19 (°C).

Specifications and information are subject to change without notice.



WMA08A

8.5 MHz LOW NOISE PRE-AMPLIFIER

REV B
July 2016

Ordering Information

| | |
|--------------|--------|
| Model Number | WMA08A |
|--------------|--------|

ESD Tray is used for the packing. Contact factory for tape and reel packing option for higher volume order.

Typical Data

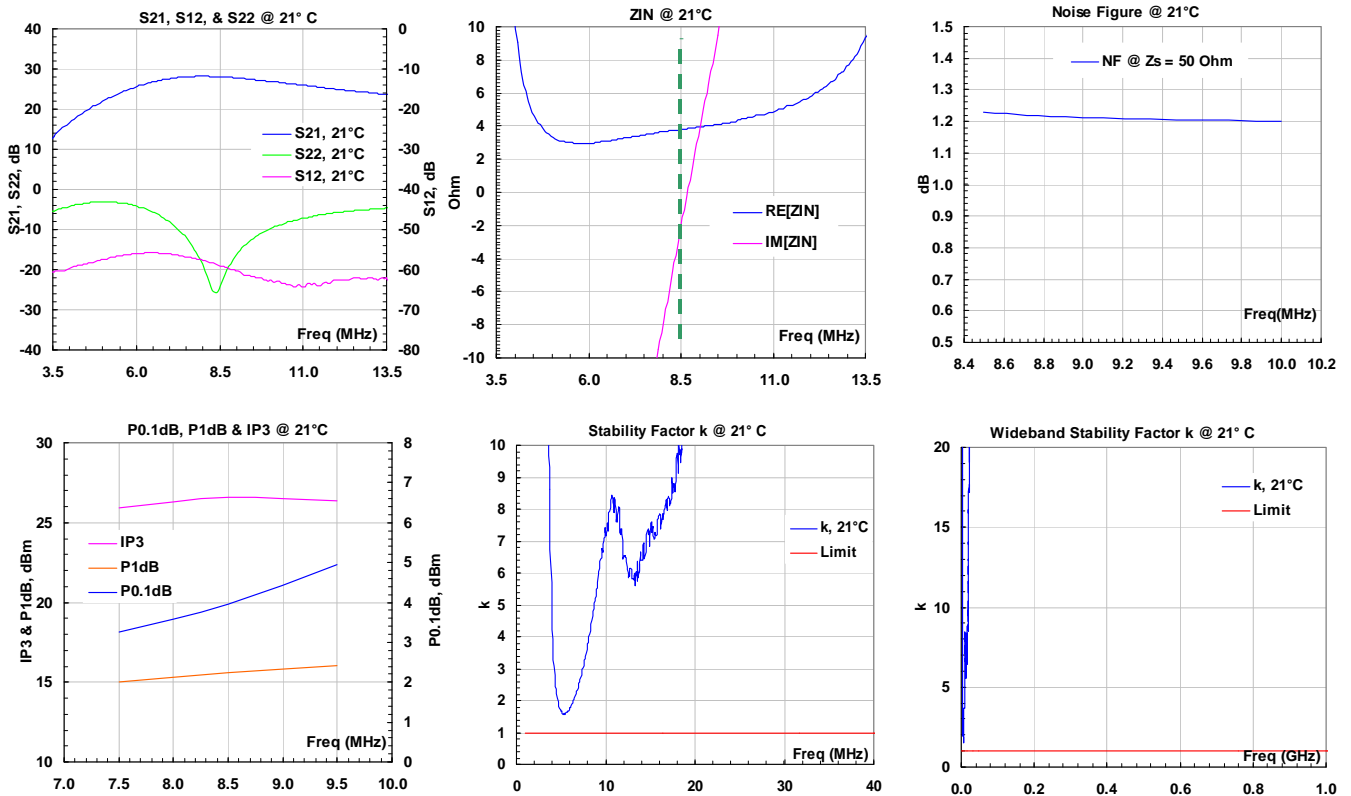

Outline,

| | | | | | |
|------|----|--------|---------|-----|------|
| PIN | 1 | 2 | 3 | 4 | CNTR |
| FCTN | IN | NC/10V | OUT/10V | GND | GND |

UNITS: INCH
[mm]
FINISH: WHITE TIN

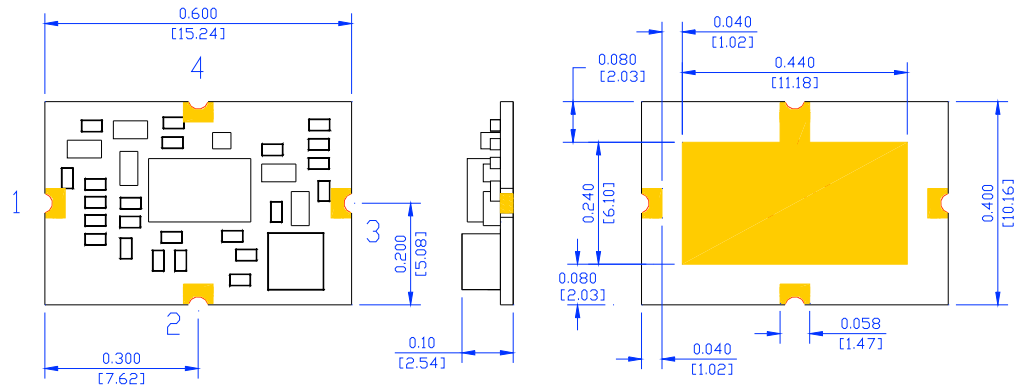

Specifications and information are subject to change without notice.



Foot Print/Mounting Layout:

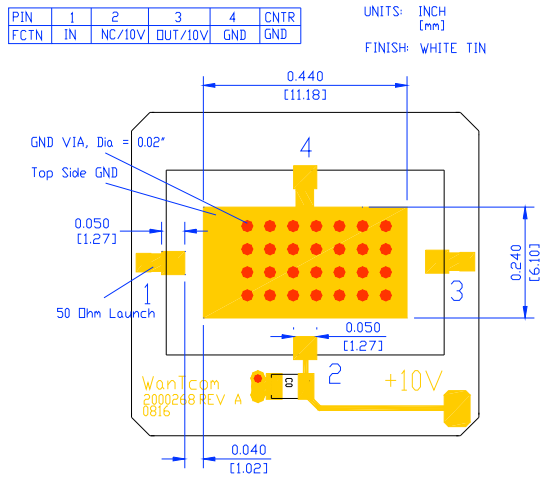

Application Notes:

A. Motherboard Layout

The recommended motherboard layout is shown in diagram of **Foot Print/Mounting Layout**. Sufficient numbers of ground vias on center ground pad are essential for the RF grounding. The width of the 50-Ohm microstrip lines at the input and output RF ports may be different for different property of the substrate. The ground plane on the backside of the substrate is needed to connect the center ground pad through the vias. The ground plane is also essential for the 50-Ohm microstrip line launches at the input and output ports.

The +10V DC voltage is applied at Pin 2 or at the output Pin 3. There is a built-in bias-T at the output port to separate the RF output signal and input +10V DC power supply.

No DC block capacitor is required at input RF ports.

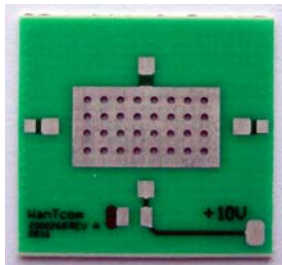

Fig. 1 Example of the motherboard

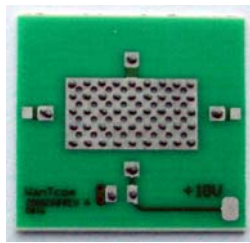

Fig. 2 Dispensed solder paste

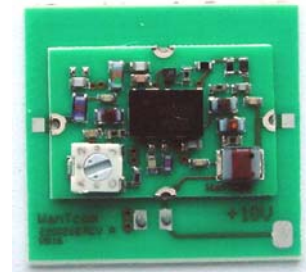

Fig. 3 Assembled part

B. Assembly

The regular low temperature and none clean solder paste such as Sn60Bi40 is recommended. The high temperature solder has been used internally for the WHM series amplifier assembly. The melting temperature point of the high temperature solder is around 217 ~ 220 °C. Thus, melting temperature of the solder paste should be below 217 °C for assembling WHM series amplifier on the test board to reduce the possible damage. The temperature melting point of the SN63 solder paste is around 183 °C and is suitable for the assembly purpose.

The Sn60Bi40 solder paste can be dispensed by a needle manually or driven by a compressed air. **Figure 2** shows the example of the dispensed solder paste pattern. Each paste dot has the diameter around 0.005" ~ 0.010" (0.125 ~ 0.250 mm).

For volume assembly, a stencil with 0.006" (0.15 mm) is recommended to print the solder paste on the circuit board.

For more detail assembly process, refer to AN-109 at www.wantcominc.com website.
