



# WMA25D

## 25.1 MHz LOW NOISE PRE-AMPLIFIER

REV C  
January 2023

### Key Features



- Frequency of 25.1 MHz
- 2.0 Ohm Input Impedance
- 0.45 dB Noise Figure
- 40.0 dBm Max P<sub>IN</sub>
- 22.0 dBm Output IP<sub>3</sub>
- 28.0 dB Gain
- 8.0 dBm P<sub>1dB</sub>
- 1.22:1 Output VSWR
- Unconditional Stable,  $k > 1$
- Single Power Supply
- Non-Magnetic

### Product Description

WMA25D is integrated with WanTcom proprietary low noise amplifier technologies, high frequency micro electronic assembly techniques, and high reliability designs to realize optimum low noise figure, large noise circles, and high performances together. With single +10.0V DC operation, the amplifier has 2.0 Ohm input impedance and unconditional stable condition. The amplifier has 0.60" x 0.40" x 0.10" surface mount package.



### Applications

- Magnetic Resonance Imaging
- RF Measurement
- Medical
- Current Sensor



Other frequencies and impedance available!

### Specifications

Summary of the key electrical specifications at room temperature, tested in the WanTcom fixture, 80051.

Index	Testing Item	Symbol	Test Constraints	Min	Nom	Max	Unit
1	Gain	S <sub>21</sub>	25.1 MHz	27.5	28.0	28.5	dB
2	Gain Variation	ΔG	25.1 +/- 0.3 MHz		+/-0.03	+/- 0.05	dB
3	Input Impedance	RE [Z <sub>in</sub> ]	25.1 MHz	1.5	2.0	2.5	Ohm
		IM [Z <sub>in</sub> ]	25.1 MHz	-3.0	0	3.0	Ohm
4	Output VSWR, 50 Ohm Impedance	SWR <sub>2</sub>	25.1 MHz			1.22:1	Ratio
5	Reverse Isolation	S <sub>12</sub>	25.1 MHz	60	65		dB
6	Noise Figure	NF	25.1 MHz, at 50 Ohm source impedance		0.45	0.55	dB
7	Output 1dB Gain Compression Point	P <sub>1dB</sub>	25.1 MHz	6	8		dBm
8	Output-Third-Order Interception Point	IP <sub>3</sub>	Two-Tone, P <sub>out</sub> = 0 dBm each, 1 MHz separation	20	22		dBm
9	Current Consumption	I <sub>dd</sub>	V <sub>dd</sub> = +10.0 V		16		mA
10	Power Supply Operating Voltage	V <sub>dd</sub>		+7	+10	+12	V
11	Thermal Resistance	R <sub>th,c</sub>	Junction to case			220	°C/W
12	Operating Temperature	T <sub>o</sub>		+10		+60	°C
13	Maximum RF Input Power	P <sub>IN, MAX</sub>	DC – 6.0 GHz, 10% Duty Cycle,			40	dBm
14	Saturate Recover Time	t <sub>sr</sub>	10% to 90% from 30 dBm Pin		8	10	uS
15	ESD Protection, None Contact	V <sub>ESDN</sub>	Output Port			16	kV
16	ESD Protection, Direct Contact	V <sub>ESD</sub>	Output Port			6	kV

### Absolute Maximum Ratings

Parameters	Units	Ratings
DC Power Supply Voltage	V	-0.5V, 15.0
Drain Current	mA	30
Total Power Dissipation	mW	350
RF Input Power, 10% Duty Cycle	dBm	40
Junction Temperature	°C	150
Storage Temperature	°C	-40 ~ +85
Operating Temperature	°C	0 ~ +70
Thermal Resistance <sup>1</sup>	°C/W	215

Operation of this device beyond any one of these parameters may cause permanent damage.

### Ordering Information

Model Number	WMA25D
--------------	--------

### Functional Block Diagram

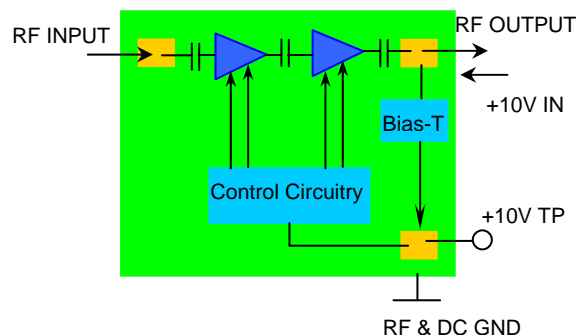

<sup>1</sup> The last stage transistor dominates the heat dissipation. The drain bias voltage is +6V and the drain current is 15.0 mA. The total power dissipation of the last stage transistor is thus 90 mW. The junction temperature arise 0.09 x 215 = 19 (°C).

Specifications and information are subject to change without notice.



ESD Tray is used for the packing. Contact factory for tape and reel packing option for higher volume order.

**Typical Data**

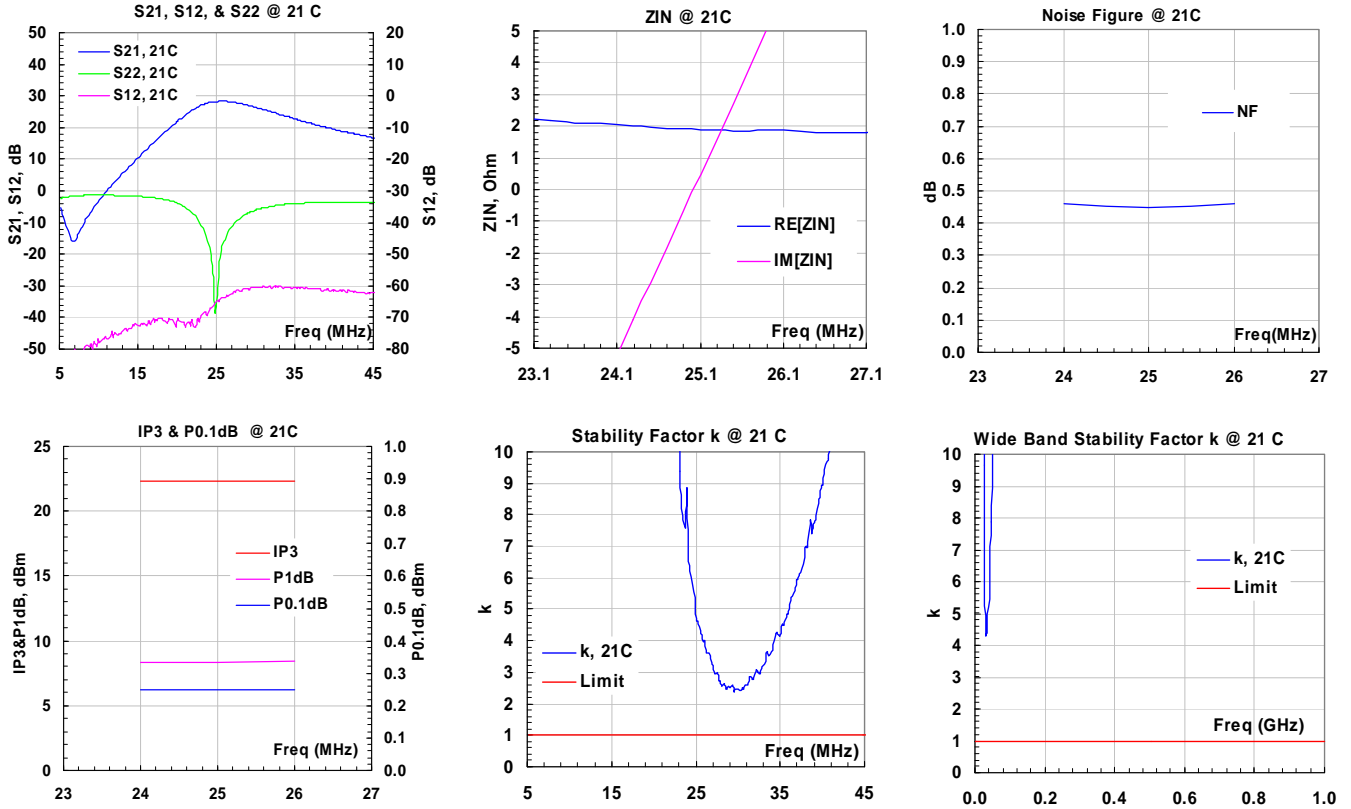

**Outline,**

PIN	1	2	3	4	CNTR
FCTN	IN	NC/10V	OUT/10V	GND	GND

UNITS: INCH  
[mm]  
FINISH: WHITE TIN

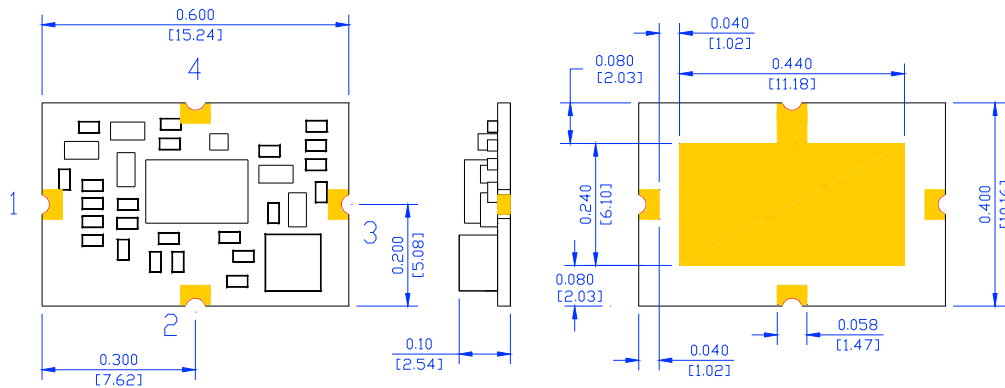

Specifications and information are subject to change without notice.



**Foot Print/Mounting Layout:**

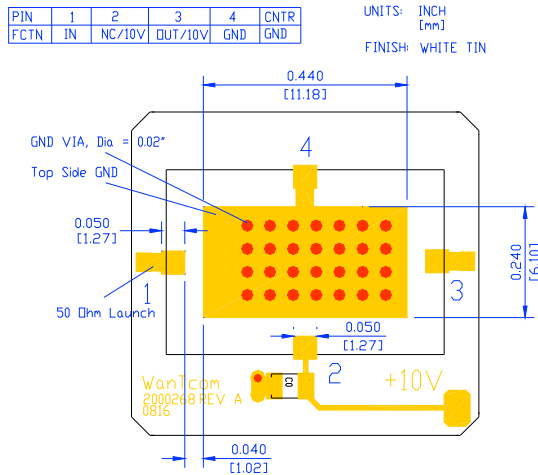

**Application Notes:**

**A. Motherboard Layout**

The recommended motherboard layout is shown in diagram of **Foot Print/Mounting Layout**. Sufficient numbers of ground vias on center ground pad are essential for the RF grounding. The width of the 50-Ohm microstrip lines at the input and output RF ports may be different for different property of the substrate. The ground plane on the backside of the substrate is needed to connect the center ground pad through the vias. The ground plane is also essential for the 50-Ohm microstrip line launches at the input and output ports.

The +10V DC voltage is applied at Pin 2 or at the output Pin 3. There is a built-in bias-T at the output port to separate the RF output signal and input +10V DC power supply.

No DC block capacitor is required at input RF ports.

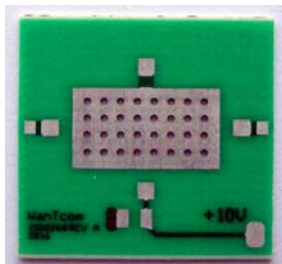

**Fig. 1** Example of the motherboard

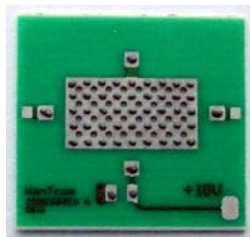

**Fig. 2** Dispensed solder paste

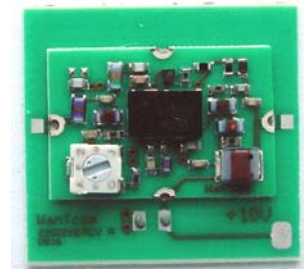

**Fig. 3** Assembled part

**B. Assembly**

The regular low temperature and none clean solder paste such as SN63 is recommended. The high temperature solder has been used internally for the WHM series amplifier assembly. The melting temperature point of the high temperature solder is around 217 ~ 220 °C. Thus, melting temperature of the solder paste should be below 217 °C for assembling WHM series amplifier on the test board to reduce the possible damage. The temperature melting point of the SN63 solder paste is around 183 °C and is suitable for the assembly purpose.

The SN63 solder paste can be dispensed by a needle manually or driven by a compressed air. **Figure 2** shows the example of the dispensed solder paste pattern. Each solder paste dot is in the diameter of 0.005" ~ 0.010" (0.125 ~ 0.250 mm).

For volume assembly, a stencil with 0.006" (0.15 mm) is recommended to print the solder paste on the circuit board.

For more detail assembly process, refer to AN-109 at [www.wantcominc.com](http://www.wantcominc.com) website.

\*\*\*\*\*

Specifications and information are subject to change without notice.